



The Future of Analog IC Technology™

EV3204DJ-00A

Fixed Frequency
White LED Driver

GENERAL DESCRIPTION

The MP3204 is a step-up converter designed for driving up to 5 series white LEDs from a single cell Lithium Ion battery. The MP3204 uses current mode, fixed frequency architecture to regulate the LED current, which is measured through an external current sense resistor. Its low 104mV feedback voltage reduces power loss and improves efficiency. The OV pin monitors the output voltage and turns off the converter if an over-voltage condition is present due to an open circuit condition.

The MP3204 includes under-voltage lockout, current limiting and thermal overload protection preventing damage in the event of an output overload.

ELECTRICAL SPECIFICATION

Parameter	Symbol	Value	Units
Input Voltage	V_{IN}	2.5 to 6	V
Number of WLEDs		1 to 5	

FEATURES

- On Board Power MOSFET
- Drives up to 5 Series White LEDs
- Up to 87% Efficiency
- Over 1MHz Fixed Switching Frequency
- Open Load Shutdown
- Low 104mV Feedback Voltage
- Soft-Start/PWM Dimming
- UVLO, Thermal Shutdown
- Internal Current Limit

APPLICATIONS

- Cell Phones
- Handheld Computers and PDAs
- Digital Still Cameras
- Small LCD Displays Application

"MPS" and "The Future of Analog IC Technology" are Trademarks of Monolithic Power Systems, Inc.

EV3204DJ-00A EVALUATION BOARD



Dimensions (1.9"X x 1.8"Y x 0.4"Z)

Board Number	MPS IC Number
EV3204DJ-00A	MP3204DJ

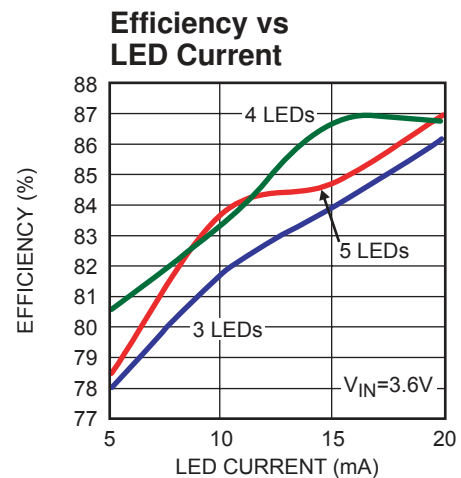

MP3204-EC01

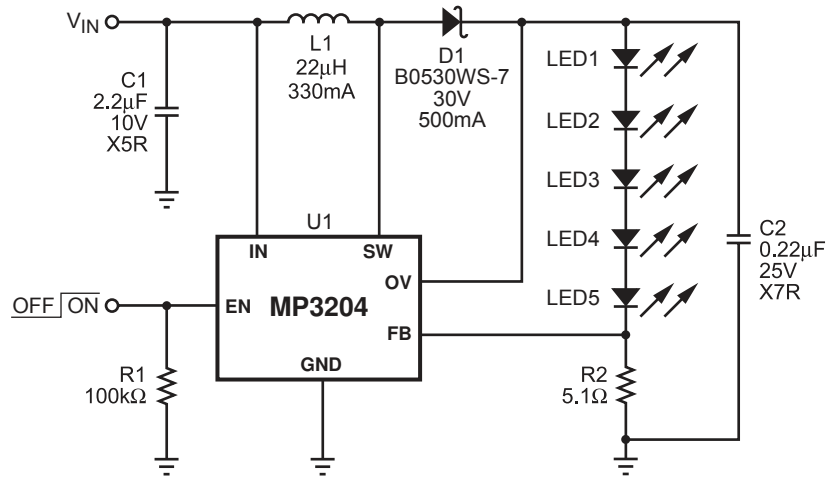
EVALUATION BOARD SCHEMATIC

EV3204_S01

EV3204DJ-00A BILL OF MATERIALS

Qty	Ref	Value	Description	Package	Manufacturer	Manufacturer P/N
1	C1	2.2µF	Ceramic Capacitor, 10V, X5R	0805	TDK	C2012X5R1A225K
1	C2	0.22µF	Ceramic Capacitor, 25V, X7R	0805	TDK	C2012X7R1E224K
1	D1		Diode Schottky, 30V, 0.5A	SOD-323	Diodes Inc.	B0530WS-7
1	L1	22µH	Inductor, 330mA	D31FB	Toko	984FB-220M
5	LED1, LED2, LED3, LED4, LED5		Not Stuffed			
1	R1	100kΩ	Resistor, 5%	0805	Panasonic	ERJ-6GEYJ104V
1	R2	5.1Ω	Resistor, 1%	0805	Panasonic	ERJ-6GEYJ5R1V
1	U1		Fixed Frequency, White LED Driver	TSOT23-6	MPS	MP3204DJ

PRINTED CIRCUIT BOARD LAYOUT

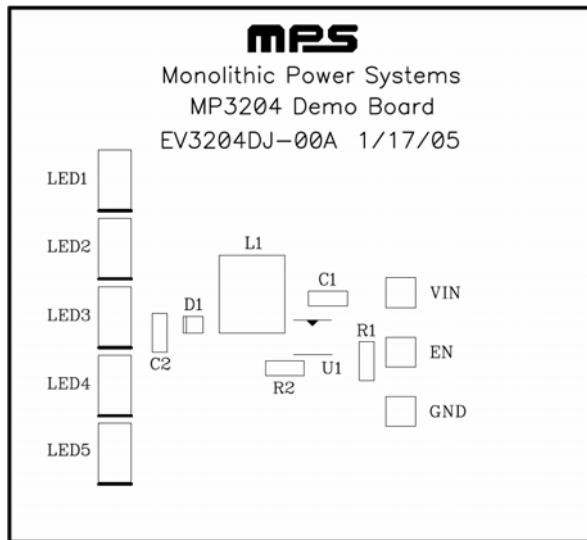

Figure 1—Top Silk Layer

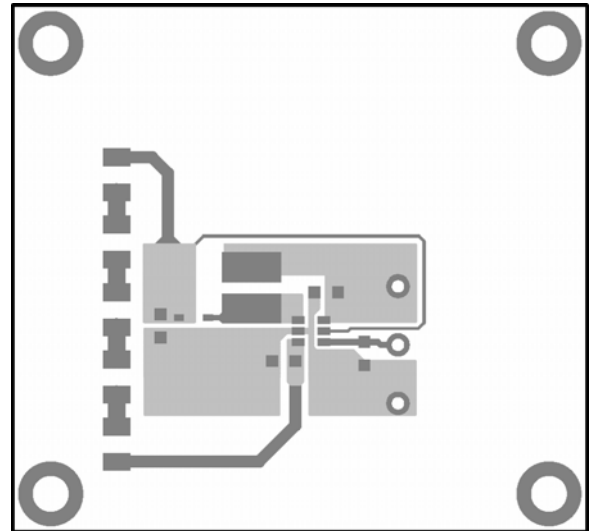

Figure 2—Top Layer

QUICK START GUIDE

1. Solder LED1 through LED5 to the board.
2. Connect the positive and negative terminals of power supply (2.5V to 6V) to VIN and GND pins, respectively.
3. Drive EN high to turn on the MP3204; low to shut it down.
4. To use burst-mode brightness control, drive EN with a PWM signal.

NOTICE: The information in this document is subject to change without notice. Please contact MPS for current specifications. Users should warrant and guarantee that third party Intellectual Property rights are not infringed upon when integrating MPS products into any application. MPS will not assume any legal responsibility for any said applications.