

SAW Filter 831.50MHz

Model: TA1494A

Part No: MP06807

Rev No: 1

A. MAXIMUM RATING:

Electrostatic Sensitive Device (ESD)

1. Input Power Level: 15dBm
2. DC voltage: 5V
3. Operating Temperature: -30°C to +85°C
4. Storage Temperature: -40°C to +85°C

B. ELECTRICAL CHARACTERISTICS:

Item	Unit	Min.	Typ.	Max.
Center frequency Fc	MHz	-	831.5	-
Insertion Loss (814 ~ 849MHz) IL	dB	-	3	4.2
Amplitude Ripple (814 ~ 849MHz)	dB	-	1.1	2.6
VSWR (814 ~ 849MHz)	-	-	2.5	2.6
Attenuation (Reference level from 0dB)				
DC ~ 794MHz	dB	30	46	-
869 ~ 900MHz	dB	20	31	-
900 ~ 2300MHz	dB	25	33	-
2300 ~ 2600MHz	dB	25	30	-
2600 ~ 2800MHz	dB	20	29	-
2800 ~ 3200MHz	dB	5	26	-
3200 ~ 6000MHz	dB	2	4	-

C. MEASUREMENT CIRCUIT:

HP Network analyzer

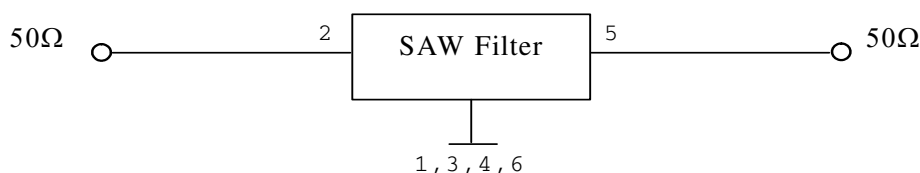

SAW Filter 831.50MHz
Part No: MP06807

Model: TA1494A
Rev No: 1

D. FREQUENCY CHARACTERISTICS:

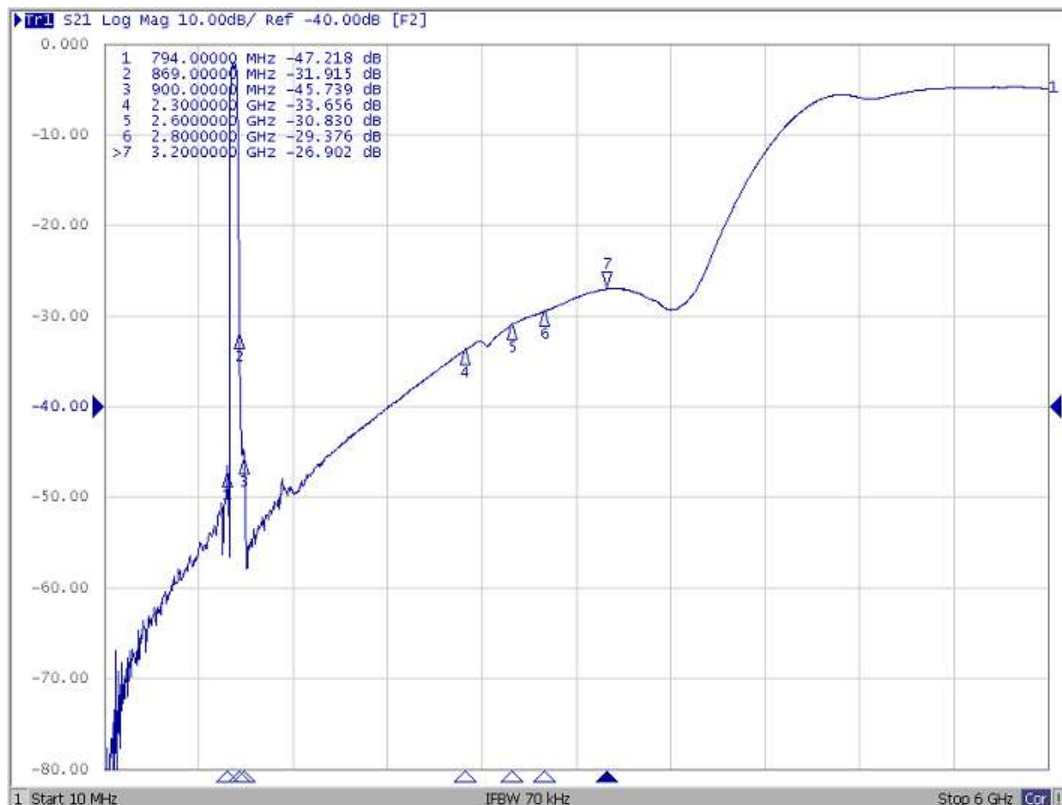
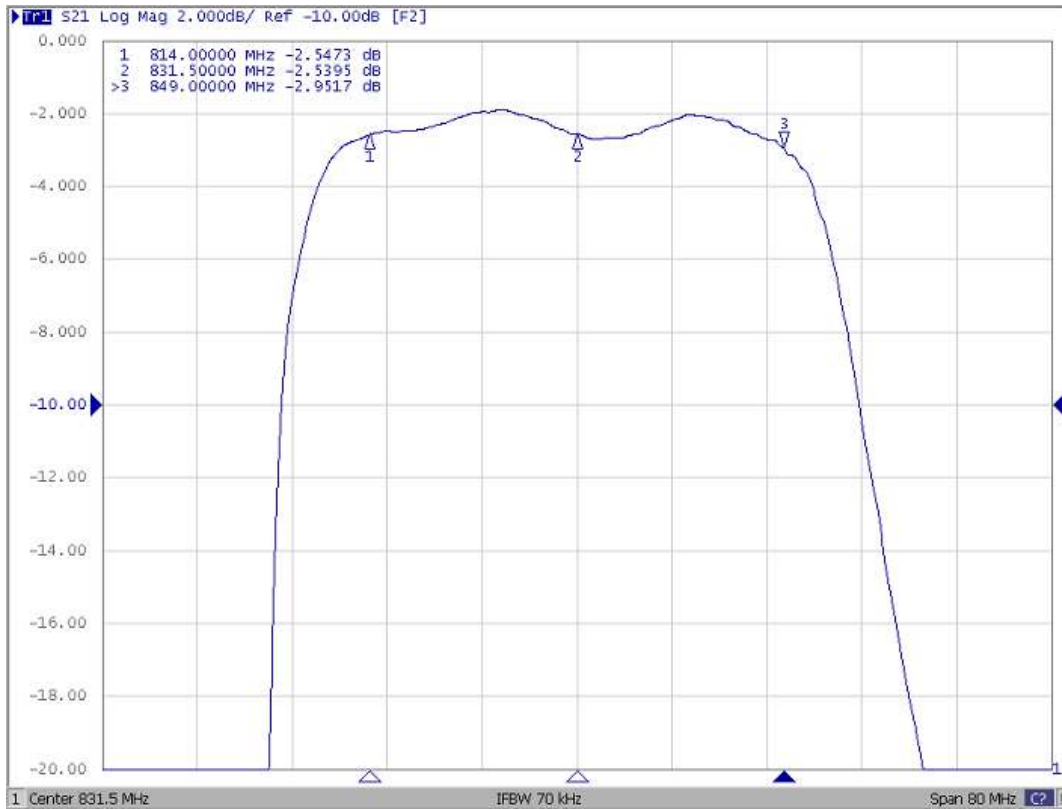

SAW Filter 831.50MHz
Part No: MP06807

Model: TA1494A
Rev No: 1

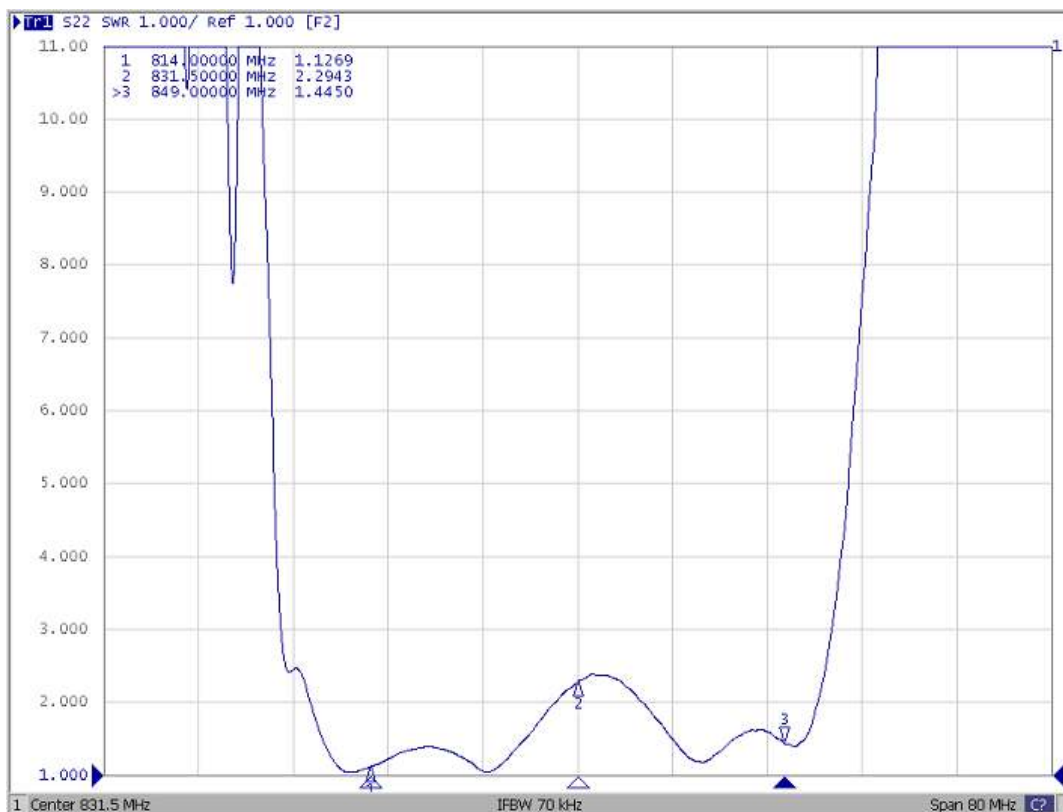
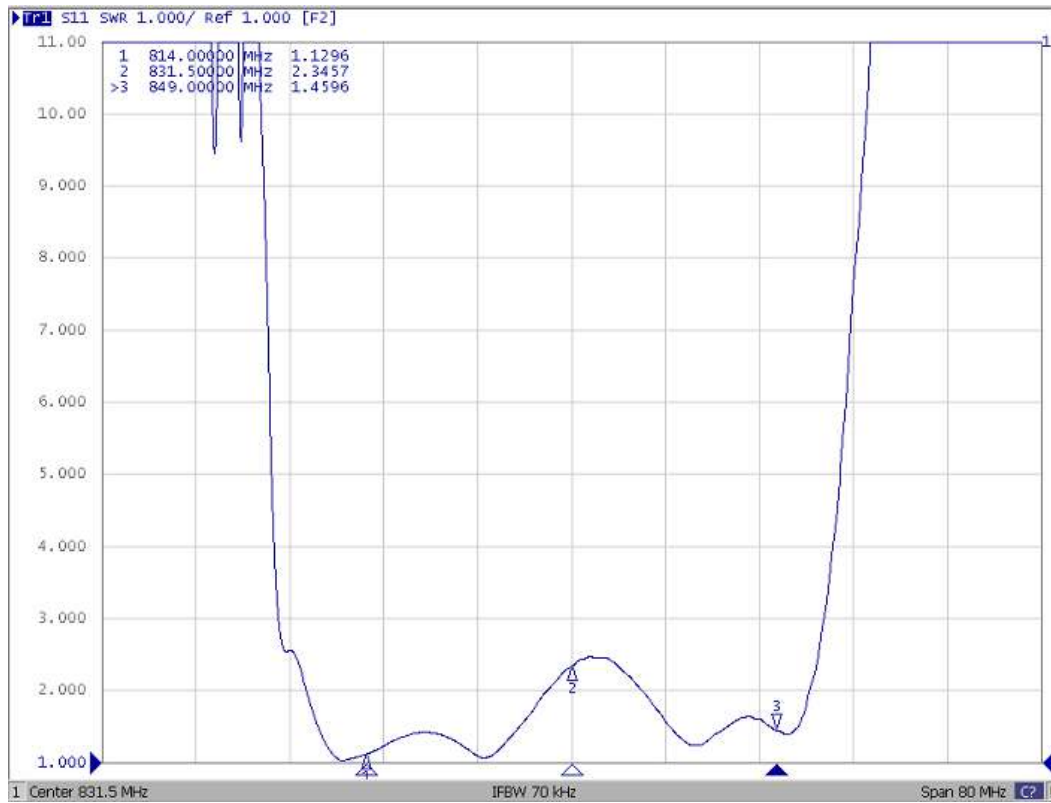

SAW Filter 831.50MHz
Part No: MP06807

Model: TA1494A
Rev No: 1

E. OUTLINE DRAWING:

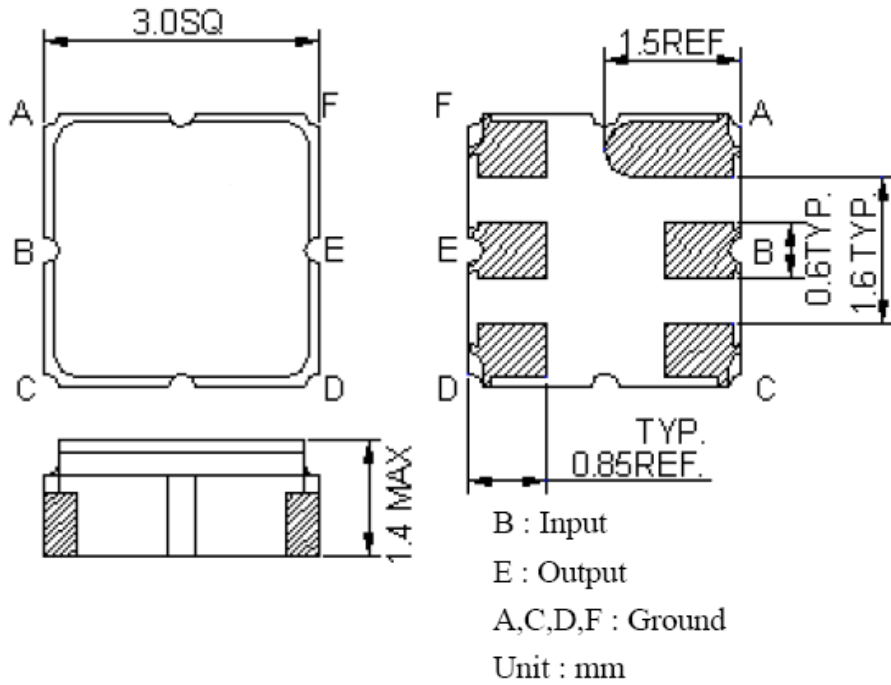

F. PCB FOOTPRINT:

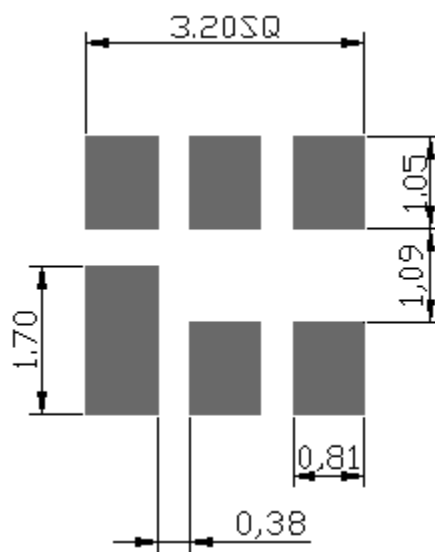

SAW Filter 831.50MHz
Part No: MP06807

Model: TA1494A
Rev No: 1

G. PACKING:

1. Reel Dimension

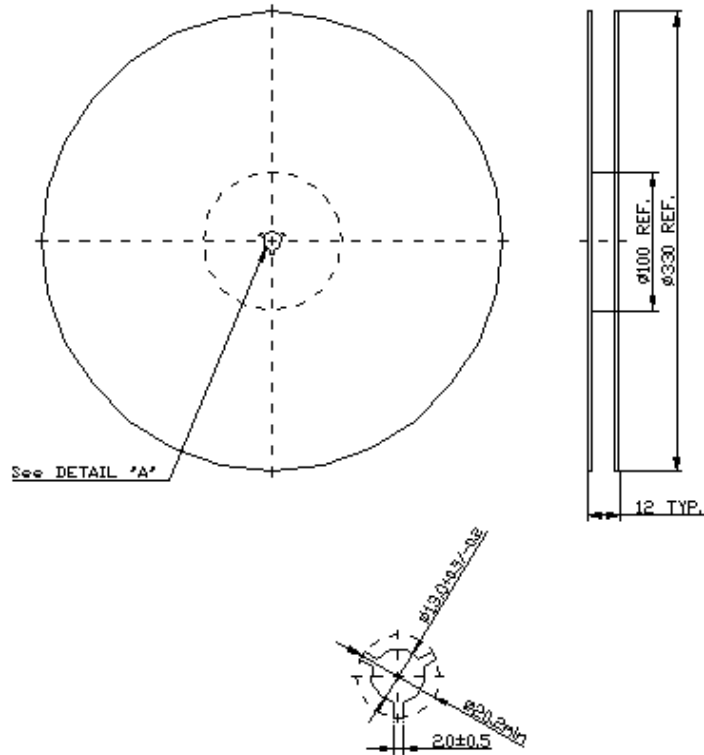

2. Tape Dimension

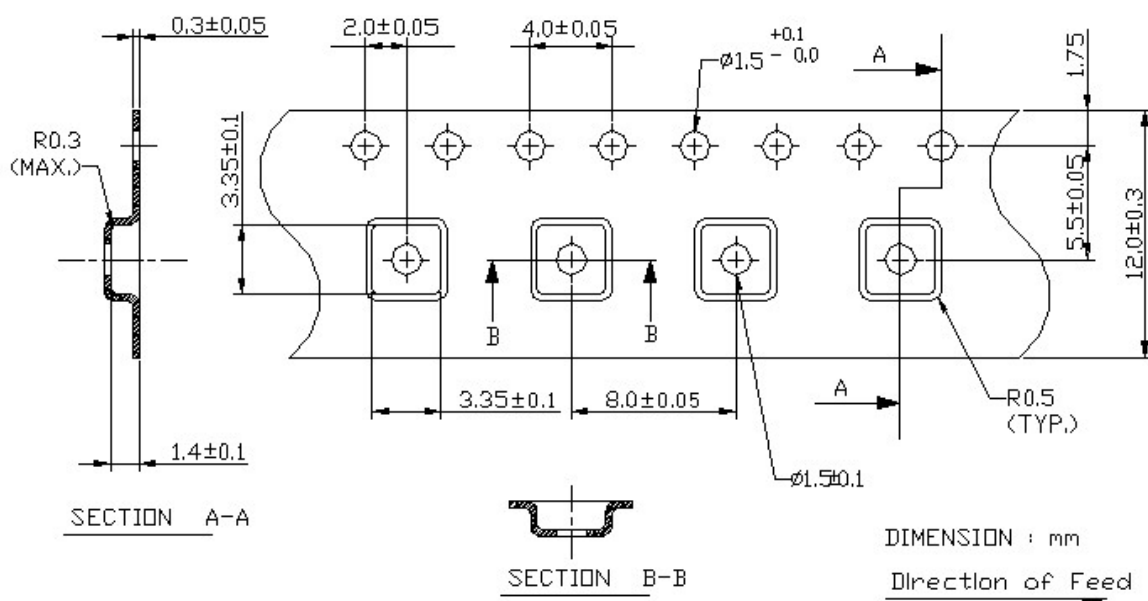

SAW Filter 831.50MHz
Part No: MP06807

Model: TA1494A
Rev No: 1

H. RECOMMENDED REFLOW PROFILE:

