

DDR4 SDRAM SODIMM Addendum

MTA8ATF2G64HZ – 16GB

Features

Information provided here is in addition to or supersedes information provided in the Micron DDR4 SODIMM Core data sheet.

- DDR4 functionality and operations supported as defined in the component data sheet
- Features and specifications supported in the Micron DDR4 SODIMM Core data sheet
- 260-pin, small-outline dual in-line memory module (SODIMM)
- Fast data transfer rates: PC4-2666, PC4-3200
- 16GB (2 Gig x 64)
- Data bus inversion (DBI) for data bus
- Single-rank
- On-board I²C serial presence-detect (SPD) EEPROM
- 16 internal banks; 4 groups of 4 banks each

Figure 1: 260-Pin SODIMM

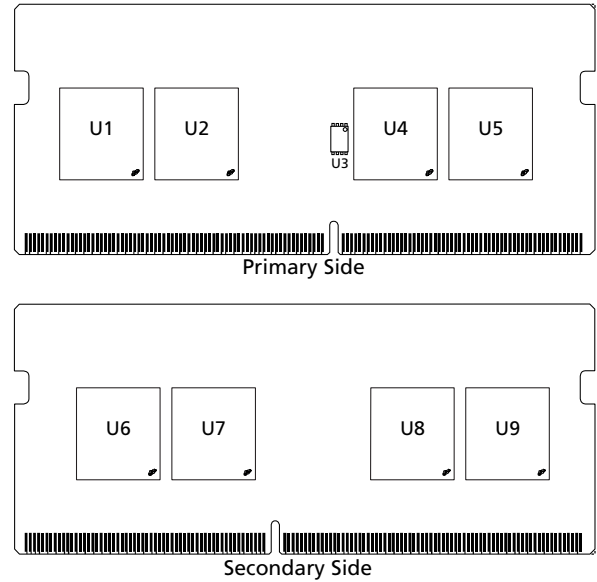

Options

- Operating temperature
 - Commercial ($0^{\circ}\text{C} \leq T_{\text{OPER}} \leq 95^{\circ}\text{C}$)
- Package
 - 260-pin DIMM (halogen-free)
- Frequency/CAS latency
 - 0.625ns @ CL = 22 (DDR4-3200)
 - 0.75ns @ CL = 19 (DDR4-2666)

Marking

– Commercial ($0^{\circ}\text{C} \leq T_{\text{OPER}} \leq 95^{\circ}\text{C}$)	None
– 260-pin DIMM (halogen-free)	Z
– 0.625ns @ CL = 22 (DDR4-3200)	-3G2
– 0.75ns @ CL = 19 (DDR4-2666)	-2G6

Table 1: Addressing

Parameter	16GB
Row address	128K A[16:0]
Column address	1K A[9:0]
Device bank group address	4 BG[1:0]
Device bank address per group	4 BA[1:0]
Device configuration	16Gb (2 Gig x 8), 16 banks
Module rank address	CS0_n



Table 2: Part Numbers and Timing Parameters – 16GB Modules

Base device: MT40A2G8,¹ 16Gb DDR4 SDRAM

Part Number ²	Module Density	Configuration	Module Bandwidth	Memory Clock/Data Rate	Clock Cycles (CL _{-n} RCD _{-n} RP)
MTA8ATF2G64HZ-3G2__	16GB	2 Gig x 64	25.6 GB/s	0.625ns/3200 MT/s	22-22-22
MTA8ATF2G64HZ-2G6__	16GB	2 Gig x 64	21.3 GB/s	0.75ns/2666 MT/s	19-19-19

- Notes: 1. The data sheet for the base device can be found on micron.com.
2. All part numbers end with a two-place code (not shown) that designates component and PCB revisions. Consult factory for current revision codes. Example: MTA8ATF2G64HZ-3G2F1.



Important Notes and Warnings

Micron Technology, Inc. ("Micron") reserves the right to make changes to information published in this document, including without limitation specifications and product descriptions. This document supersedes and replaces all information supplied prior to the publication hereof. You may not rely on any information set forth in this document if you obtain the product described herein from any unauthorized distributor or other source not authorized by Micron.

Automotive Applications. Products are not designed or intended for use in automotive applications unless specifically designated by Micron as automotive-grade by their respective data sheets. Distributor and customer/distributor shall assume the sole risk and liability for and shall indemnify and hold Micron harmless against all claims, costs, damages, and expenses and reasonable attorneys' fees arising out of, directly or indirectly, any claim of product liability, personal injury, death, or property damage resulting directly or indirectly from any use of non-automotive-grade products in automotive applications. Customer/distributor shall ensure that the terms and conditions of sale between customer/distributor and any customer of distributor/customer (1) state that Micron products are not designed or intended for use in automotive applications unless specifically designated by Micron as automotive-grade by their respective data sheets and (2) require such customer of distributor/customer to indemnify and hold Micron harmless against all claims, costs, damages, and expenses and reasonable attorneys' fees arising out of, directly or indirectly, any claim of product liability, personal injury, death, or property damage resulting from any use of non-automotive-grade products in automotive applications.

Critical Applications. Products are not authorized for use in applications in which failure of the Micron component could result, directly or indirectly in death, personal injury, or severe property or environmental damage ("Critical Applications"). Customer must protect against death, personal injury, and severe property and environmental damage by incorporating safety design measures into customer's applications to ensure that failure of the Micron component will not result in such harms. Should customer or distributor purchase, use, or sell any Micron component for any critical application, customer and distributor shall indemnify and hold harmless Micron and its subsidiaries, subcontractors, and affiliates and the directors, officers, and employees of each against all claims, costs, damages, and expenses and reasonable attorneys' fees arising out of, directly or indirectly, any claim of product liability, personal injury, or death arising in any way out of such critical application, whether or not Micron or its subsidiaries, subcontractors, or affiliates were negligent in the design, manufacture, or warning of the Micron product.

Customer Responsibility. Customers are responsible for the design, manufacture, and operation of their systems, applications, and products using Micron products. ALL SEMICONDUCTOR PRODUCTS HAVE INHERENT FAILURE RATES AND LIMITED USEFUL LIVES. IT IS THE CUSTOMER'S SOLE RESPONSIBILITY TO DETERMINE WHETHER THE MICRON PRODUCT IS SUITABLE AND FIT FOR THE CUSTOMER'S SYSTEM, APPLICATION, OR PRODUCT. Customers must ensure that adequate design, manufacturing, and operating safeguards are included in customer's applications and products to eliminate the risk that personal injury, death, or severe property or environmental damages will result from failure of any semiconductor component.

Limited Warranty. In no event shall Micron be liable for any indirect, incidental, punitive, special or consequential damages (including without limitation lost profits, lost savings, business interruption, costs related to the removal or replacement of any products or rework charges) whether or not such damages are based on tort, warranty, breach of contract or other legal theory, unless explicitly stated in a written agreement executed by Micron's duly authorized representative.



DQ Maps

Table 3: Component-to-Module DQ Map

Component Reference Number	Component DQ	Module DQ	Module Pin Number	Component Reference Number	Component DQ	Module DQ	Module Pin Number
U1	0	7	17	U2	0	23	59
	1	5	3		1	21	45
	2	6	16		2	22	58
	3	4	4		3	20	46
	4	3	21		4	19	63
	5	0	8		5	16	50
	6	2	20		6	18	62
	7	1	7		7	17	49
U4	0	38	183	U5	0	55	225
	1	37	169		1	52	211
	2	39	182		2	54	224
	3	36	170		3	53	212
	4	34	187		4	51	229
	5	32	174		5	48	216
	6	35	186		6	50	228
	7	33	173		7	49	215
U6	0	60	232	U7	0	40	195
	1	62	245		1	43	208
	2	61	233		2	41	194
	3	63	246		3	42	207
	4	57	236		4	45	190
	5	58	249		5	46	203
	6	56	237		6	44	191
	7	59	250		7	47	204
U8	0	28	66	U9	0	12	24
	1	30	79		1	15	37
	2	29	67		2	13	25
	3	31	80		3	14	38
	4	25	71		4	9	29
	5	26	83		5	10	41
	6	24	70		6	8	28
	7	27	84		7	11	42



I_{DD} Specifications

Table 4: DDR4 I_{DD} Specifications and Conditions (0° ≤ T_C ≤ 85°) – 16GB (Die Revision E)

Values are for the MT40A2G8 DDR4 SDRAM only and are computed from values specified in the 16Gb (2 Gig x 8) component data sheet

Parameter	Symbol	3200	2666	Units
One bank ACTIVATE-PRECHARGE current	I _{DD0}	480	464	mA
One bank ACTIVATE-PRECHARGE, Word Line Boost, I _{pp} current	I _{pp0}	24	24	mA
One bank ACTIVATE-READ-PRECHARGE current	I _{DD1}	568	552	mA
Precharge standby current	I _{DD2N}	360	344	mA
Precharge standby ODT current	I _{DD2NT}	408	392	mA
Precharge power-down current	I _{DD2P}	304	304	mA
Precharge quiet standby current	I _{DD2Q}	336	336	mA
Active standby current	I _{DD3N}	488	472	mA
Active standby I _{pp} current	I _{pp3N}	16	16	mA
Active power-down current	I _{DD3P}	400	384	mA
Burst read current	I _{DD4R}	1296	1168	mA
Burst write current	I _{DD4W}	1024	936	mA
Burst refresh current (1x REF)	I _{DD5R}	544	544	mA
Burst refresh I _{pp} current (1x REF)	I _{pp5R}	32	32	mA
Self refresh current: Normal temperature range (0°C to 85°C)	I _{DD6N}	424	424	mA
Self refresh current: Extended temperature range (0°C to 95°C)	I _{DD6E}	904	904	mA
Self refresh current: Reduced temperature range (0°C to 45°C)	I _{DD6R}	160	160	mA
Auto self refresh current (25°C)	I _{DD6A}	88	88	mA
Auto self refresh current (45°C)	I _{DD6A}	160	160	mA
Auto self refresh current (75°C)	I _{DD6A}	408	408	mA
Auto self refresh current (95°C)	I _{DD6A}	904	904	mA
Auto self refresh I _{pp} current	I _{pp6X}	48	48	mA
Bank interleave read current	I _{DD7}	1480	1448	mA
Bank interleave read I _{pp} current	I _{pp7}	64	64	mA
Maximum power-down current	I _{DD8}	288	288	mA

Notes: 1. When T_C > 85°C, the I_{DD} and I_{pp} values must be derated. Refer to the base device data sheet I_{DD} and I_{pp} specification tables for derating values for the applicable die-revision.



16GB (x64, SR) 260-Pin DDR4 SODIMM I_{DD} Specifications

Table 5: DDR4 I_{DD} Specifications and Conditions (0° ≤ T_C ≤ 85°) – 16GB (Die Revision B)

Values are for the MT40A2G8 DDR4 SDRAM only and are computed from values specified in the 16Gb (2 Gig x 8) component data sheet

Parameter	Symbol	3200	2666	Units
One bank ACTIVATE-PRECHARGE current	I _{DD0}	504	488	mA
One bank ACTIVATE-PRECHARGE, Word Line Boost, I _{pp} current	I _{PP0}	32	32	mA
One bank ACTIVATE-READ-PRECHARGE current	I _{DD1}	592	576	mA
Precharge standby current	I _{DD2N}	416	400	mA
Precharge standby ODT current	I _{DD2NT}	448	432	mA
Precharge power-down current	I _{DD2P}	344	344	mA
Precharge quiet standby current	I _{DD2Q}	376	376	mA
Active standby current	I _{DD3N}	640	624	mA
Active standby I _{pp} current	I _{PP3N}	24	24	mA
Active power-down current	I _{DD3P}	552	544	mA
Burst read current	I _{DD4R}	1616	1456	mA
Burst write current	I _{DD4W}	1464	1328	mA
Burst refresh current (1x REF)	I _{DD5R}	632	616	mA
Burst refresh I _{pp} current (1x REF)	I _{PP5R}	40	40	mA
Self refresh current: Normal temperature range (0°C to 85°C)	I _{DD6N}	536	536	mA
Self refresh current: Extended temperature range (0°C to 95°C)	I _{DD6E}	968	968	mA
Self refresh current: Reduced temperature range (0°C to 45°C)	I _{DD6R}	232	232	mA
Auto self refresh current (25°C)	I _{DD6A}	80	80	mA
Auto self refresh current (45°C)	I _{DD6A}	232	232	mA
Auto self refresh current (75°C)	I _{DD6A}	488	488	mA
Auto self refresh current (95°C)	I _{DD6A}	968	968	mA
Auto self refresh I _{pp} current	I _{PP6X}	88	88	mA
Bank interleave read current	I _{DD7}	1568	1520	mA
Bank interleave read I _{pp} current	I _{PP7}	80	80	mA
Maximum power-down current	I _{DD8}	320	320	mA

Notes: 1. When T_C > 85°C, the I_{DD} and I_{pp} values must be derated. Refer to the base device data sheet I_{DD} and I_{pp} specification tables for derating values for the applicable die-revision.



16GB (x64, SR) 260-Pin DDR4 SODIMM I_{DD} Specifications

Table 6: DDR4 I_{DD} Specifications and Conditions (0° ≤ T_C ≤ 85°) – 16GB (Die Revision F)

Values are for the MT40A2G8 DDR4 SDRAM only and are computed from values specified in the 16Gb (2 Gig x 8) component data sheet

Parameter	Symbol	3200	2666	Units
One bank ACTIVATE-PRECHARGE current	I _{DD0}	480	464	mA
One bank ACTIVATE-PRECHARGE, Word Line Boost, I _{pp} current	I _{PP0}	24	24	mA
One bank ACTIVATE-READ-PRECHARGE current	I _{DD1}	568	552	mA
Precharge standby current	I _{DD2N}	360	344	mA
Precharge standby ODT current	I _{DD2NT}	408	392	mA
Precharge power-down current	I _{DD2P}	304	304	mA
Precharge quiet standby current	I _{DD2Q}	336	336	mA
Active standby current	I _{DD3N}	488	472	mA
Active standby I _{pp} current	I _{PP3N}	16	16	mA
Active power-down current	I _{DD3P}	400	384	mA
Burst read current	I _{DD4R}	1120	1000	mA
Burst write current	I _{DD4W}	896	816	mA
Burst refresh current (1x REF)	I _{DD5R}	544	544	mA
Burst refresh I _{pp} current (1x REF)	I _{PP5R}	32	32	mA
Self refresh current: Normal temperature range (0°C to 85°C)	I _{DD6N}	424	424	mA
Self refresh current: Extended temperature range (0°C to 95°C)	I _{DD6E}	720	720	mA
Self refresh current: Reduced temperature range (0°C to 45°C)	I _{DD6R}	160	160	mA
Auto self refresh current (25°C)	I _{DD6A}	88	88	mA
Auto self refresh current (45°C)	I _{DD6A}	160	160	mA
Auto self refresh current (75°C)	I _{DD6A}	408	408	mA
Auto self refresh current (95°C)	I _{DD6A}	720	720	mA
Auto self refresh I _{pp} current	I _{PP6X}	48	48	mA
Bank interleave read current	I _{DD7}	1336	1304	mA
Bank interleave read I _{pp} current	I _{PP7}	64	64	mA
Maximum power-down current	I _{DD8}	288	288	mA

Notes: 1. When T_C > 85°C, the I_{DD} and I_{pp} values must be derated. Refer to the base device data sheet I_{DD} and I_{pp} specification tables for derating values for the applicable die-revision.

Functional Block Diagram

Figure 2: Functional Block Diagram

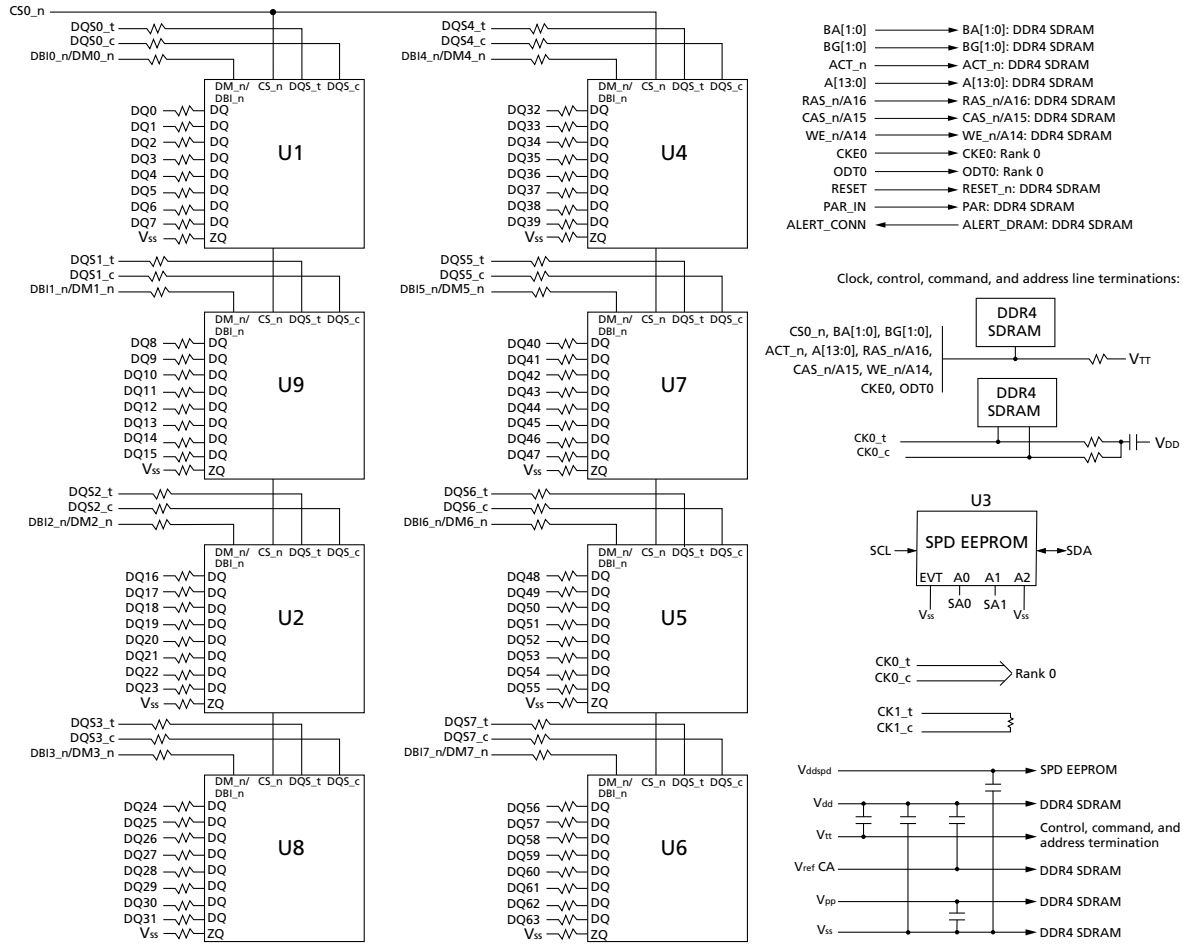

Note: 1. The ZQ ball on each DDR4 component is connected to an external 240Ω ±1% resistor that is tied to ground. It is used for the calibration of the component's ODT and output driver.

Module Dimensions

Figure 3: 260-Pin DDR4 SODIMM - PCB 2871

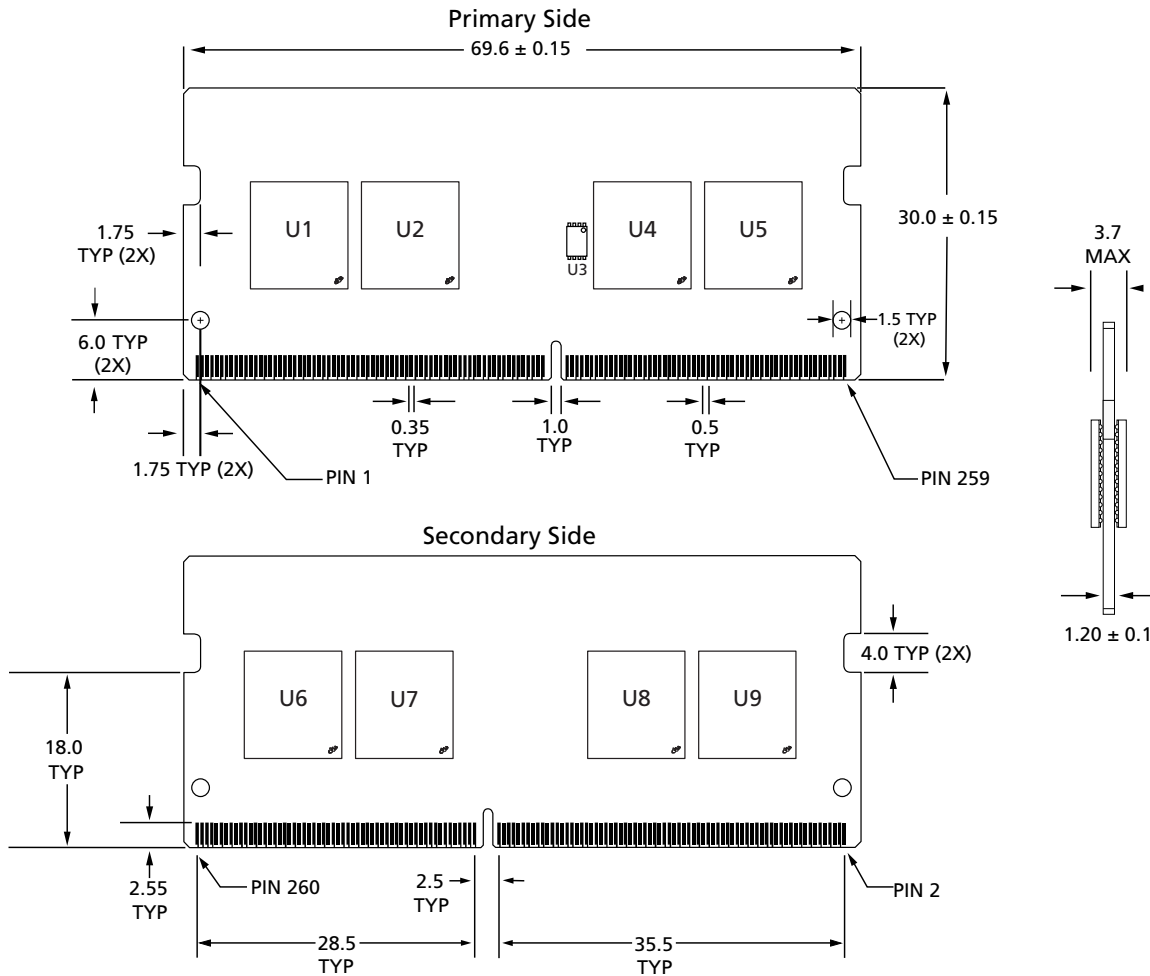

- Notes:
1. All dimensions are in millimeters; MAX/MIN or typical (TYP) where noted.
 2. Tolerance on all dimensions ± 0.15 mm unless otherwise specified.
 3. The dimensional diagram is for reference only.

Figure 4: 260-Pin DDR4 SODIMM - PCB 3221

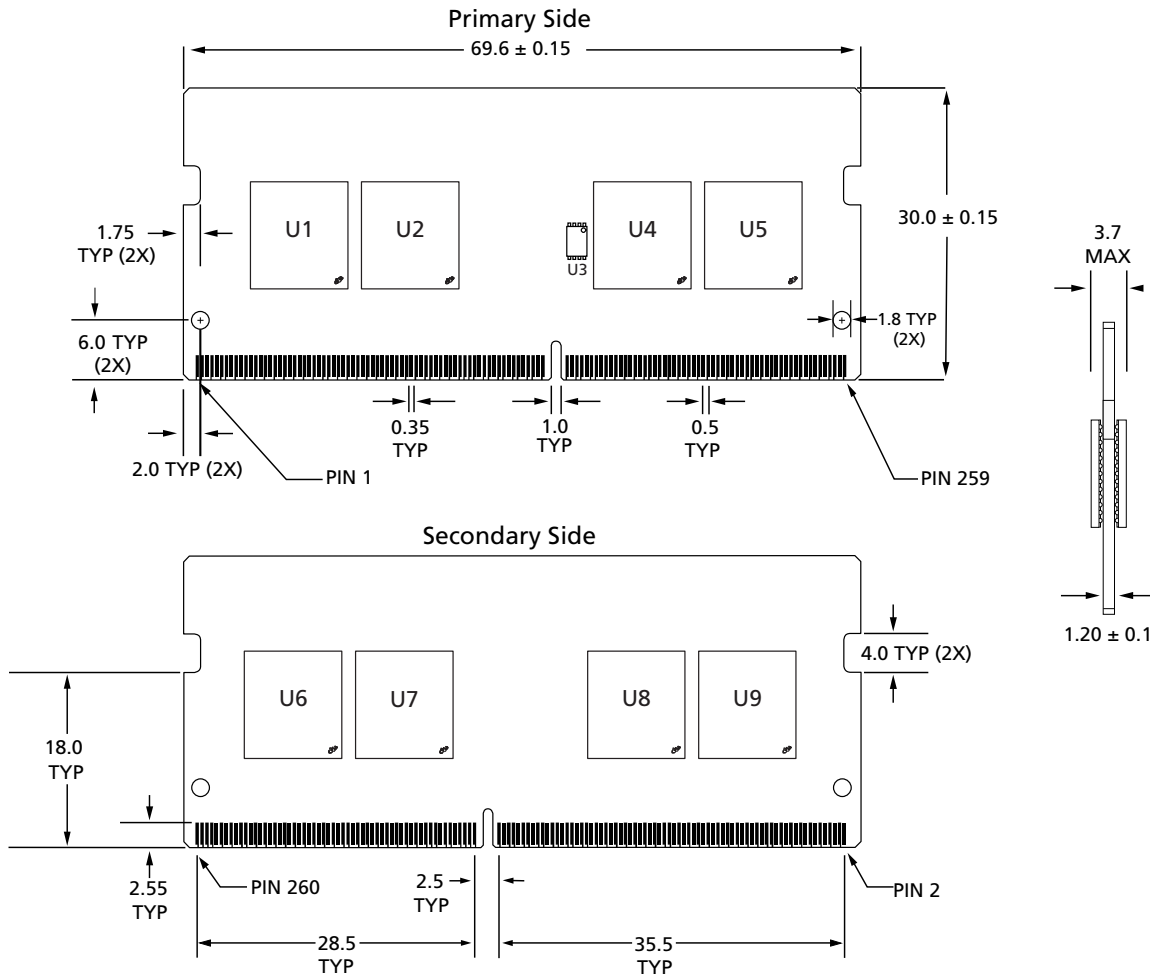

- Notes: 1. All dimensions are in millimeters; MAX/MIN or typical (TYP) where noted.
 2. Tolerance on all dimensions ± 0.15 mm unless otherwise specified.
 3. The dimensional diagram is for reference only.

8000 S. Federal Way, P.O. Box 6, Boise, ID 83707-0006
 208-368-4000, micron.com/support

Micron and the Micron logo are trademarks of Micron Technology, Inc.
 All other trademarks are the property of their respective owners.

This data sheet contains minimum and maximum limits specified over the power supply and temperature range set forth herein. Although considered final, these specifications are subject to change, as further product development and data characterization sometimes occur.