

3mm (T1) Package Discrete LED YELLOW, Low Current



3YDL-X

- ◆ Industry Standard 3mm (T1) Package
- ◆ RoHS Compliant
- ◆ Diffused Lens
- ◆ Available in Flange (F) and Shouldered (S) Lead Frame styles
- ◆ 2 mA Low Operating Current
- ◆ Ideal for Status Indication and Display

Bivar 3mm T1 Package 2 mA Low Current LED is special binned at 2 mA and is ideal for those applications where lower power budget is required such as solar panel or battery-powered portable devices. Bivar offers diffused LED lens for uniform light output. The Flanged LED is ideal for Panel Mount Clip & Ring assemblies. The Shouldered Lead frame LED is ideal for vertical spacer assemblies without lead bends and also has a built in strain relief feature which is ideal for right angle holder assemblies that require lead bends.

Part Number	Material	Emitted Color	Peak. Wavelength λ_p (nm) TYP.	Lens Appearance	Viewing Angle
3YDL-F	GaAsP/GaP	YELLOW	590nm	Yellow Diffused	35°
3YDL-S				Yellow Diffused	40°

Part Number Designation

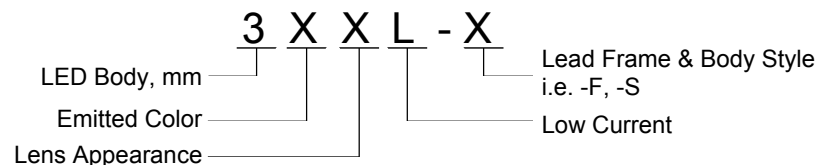

Bivar reserves the right to make changes at any time without notice.

3mm (T1) Package Discrete LED YELLOW, Low Current



Outline Dimensions

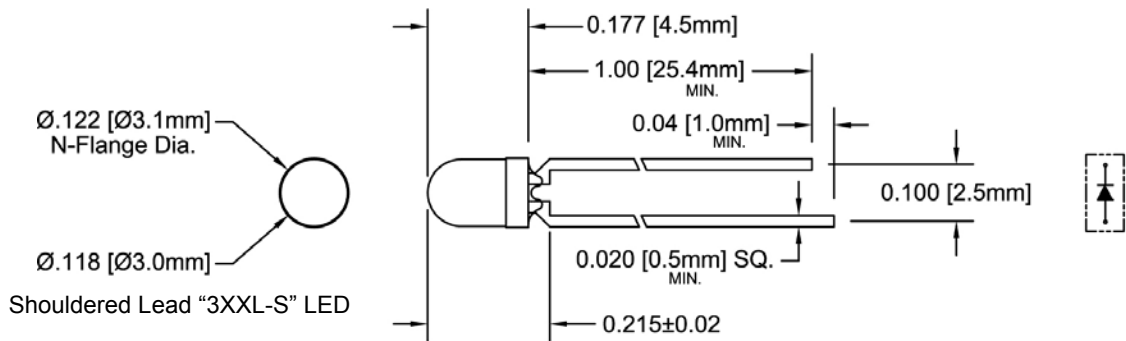
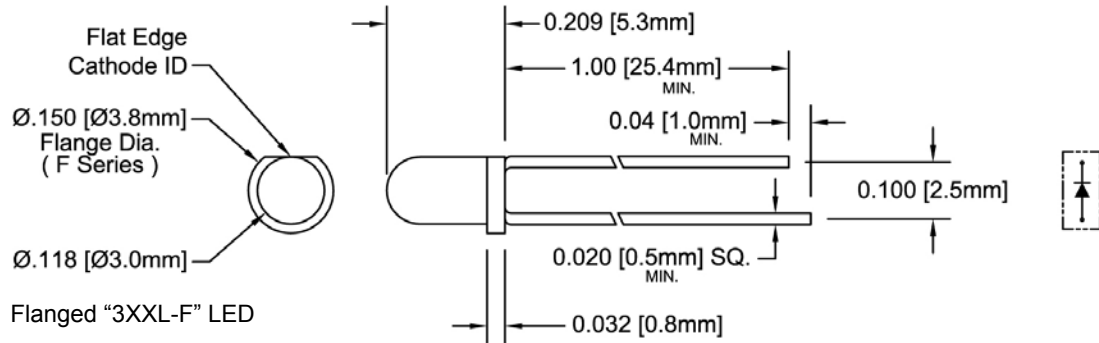

Recommended Mounting

Hole Size = $\text{Ø}0.032^{+0.003}_{-0.002}$

Outline Drawings Notes:

1. All dimensions are in inches [millimeters].
2. Standard tolerance: ± 0.010 " unless otherwise noted.
3. Tolerance of overall epoxy outline: ± 0.020 " unless otherwise noted.
4. Epoxy meniscus may extend to 0.060" max.

Bivar reserves the right to make changes at any time without notice.

3mm (T1) Package Discrete LED YELLOW, Low Current



Absolute Maximum Ratings

T_A = 25°C unless otherwise noted

Power Dissipation	10 mW
Forward Current (DC)	7 mA
Peak Forward Current ¹	/ mA
Reverse Voltage	5 V
Operating Temperature Range	-25 ~ +85°C
Storage Temperature Range	-30 ~ +100°C
Lead Soldering Temperature (3 mm from the base of the epoxy bulb) ²	260°C

Notes: 1. 10% Duty Cycle, Pulse Width ≤ 0.1 msec. 2. Solder time less than 5 seconds at temperature extreme.

Electrical / Optical Characteristics

T_A = 25°C & I_F = 2 mA unless otherwise noted

Part Number	Forward Voltage (V) ¹			Recommend Forward Current (mA)			Reverse Current (μA)	Dominant Wavelength (nm) ²			Luminous Intensity I _v (mcd)			Viewing Angle 2Θ ½ (deg)
	MIN	TYP	MAX	MIN	TYP	MAX	MAX	MIN	TYP	MAX	MIN	TYP	MAX	TYP
3YDL-F	/	2.0	2.6	/	2	/	100	/	/	/	/	2	/	35
3YDL-S	/	2.0	2.6	/	2	/	100	/	/	/	/	2	/	40

Notes: 1. Tolerance of forward voltage : ±0.05V. 2. Tolerance of dominant wavelength : ±1.0nm.

Bivar reserves the right to make changes at any time without notice.

3mm (T1) Package Discrete LED YELLOW, Low Current



Typical Electrical / Optical Characteristics

$T_A = 25^\circ\text{C}$ unless otherwise noted

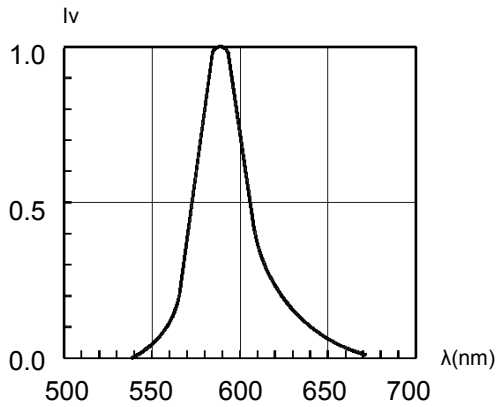

Fig. 1 Relative Luminous Intensity vs. Wavelength

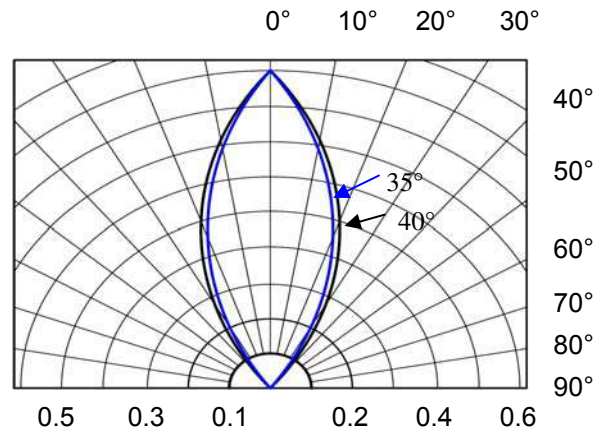

Fig. 2 Directivity Radiation Diagram

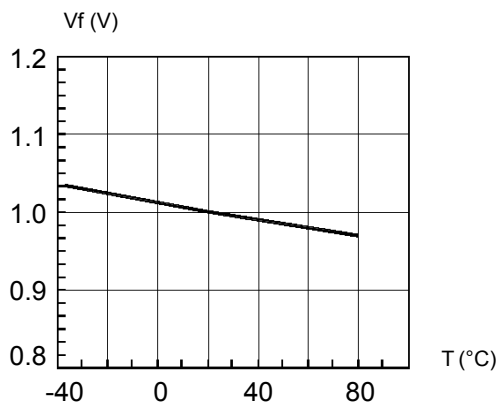

Fig. 3 Forward Voltage vs. Temperature

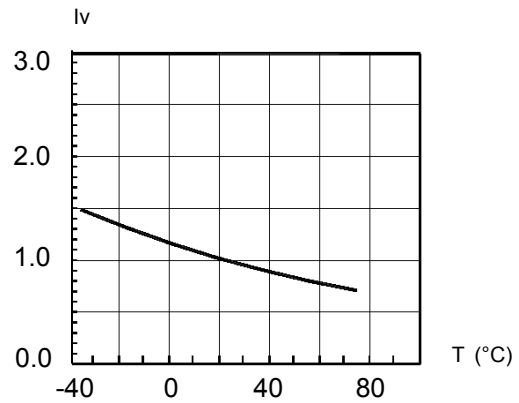

Fig. 4 Relative Luminous Intensity vs. Temperature

Bivar reserves the right to make changes at any time without notice.

3mm (T1) Package Discrete LED YELLOW, Low Current



Recommended Soldering Conditions

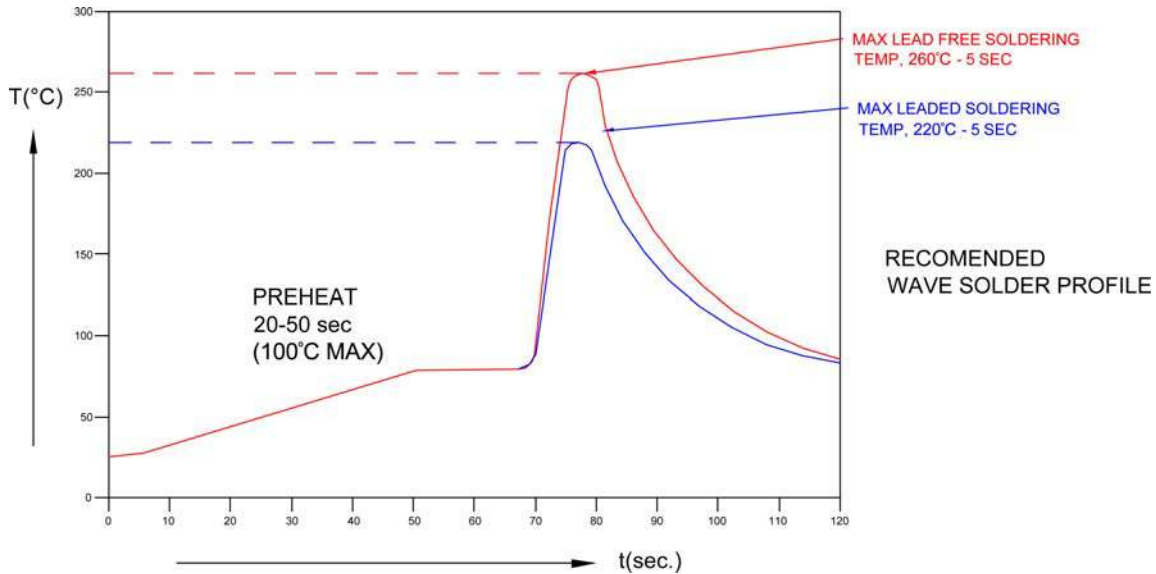

Recommended Lead Free Wave Soldering Profile	
Preheat Temperature: 100°C Max.	Peak Temperature: 260°C Max.
Preheat Time: 20 ~ 50 Seconds	Solder Time Above 217°C: 5 Seconds Max.
Note: Turn off top heater at preheat to prevent the lamp body directly exposed to the heat source.	

Packaging and Labeling Plan

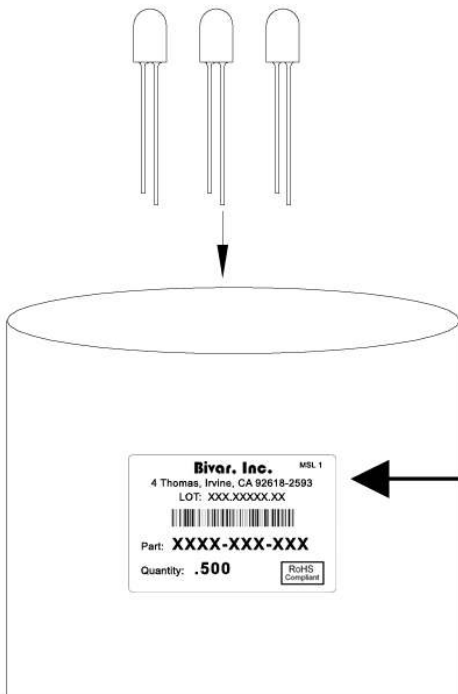

Bivar, Inc. MSL 1

4 Thomas, Irvine, CA 92618-2593
LOT: XXX.XXXXX.XX

Part: **XXXX-XXX-XXX**

Quantity: **.500**

RoHS
Compliant

Anti-Static Poly Bag with Desiccant
(500 pcs Max. per Bag)

Bivar reserves the right to make changes at any time without notice.