

REVISIONS					
P	LTR	DESCRIPTION	DATE	DWN	APVD
A2		Released as per ECR-07-012890	10-07-07	SK	TS
A3		Released as per ECO-09-027197	15DEC09	KK	AEG
A4		Released as per ECR-17-014011	16JAN18	RSM	MKO

- NOTES
- 1 Material: Housing: aluminium diecasting alloy
 - 2 Surface:- Powder varnish-grey
Varnish black
 - 3 Varnish on the inside not necessarily
 - 4 Packaging quantity: 5 pieces
 - 5 OBSOLETE PARTS: OBSOLETE CIS STREAMLINING PER D.RENAUD/D.SINISI

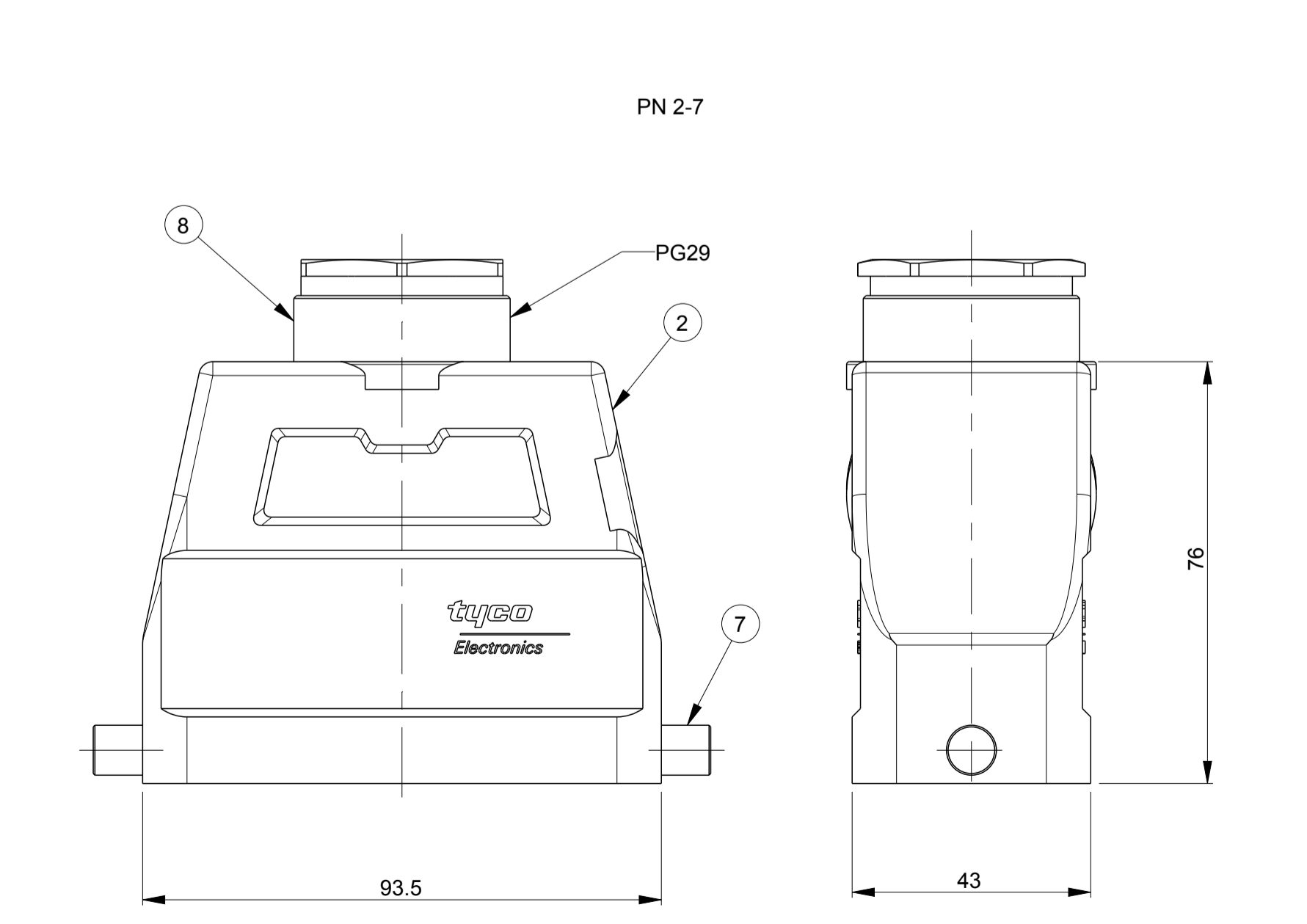
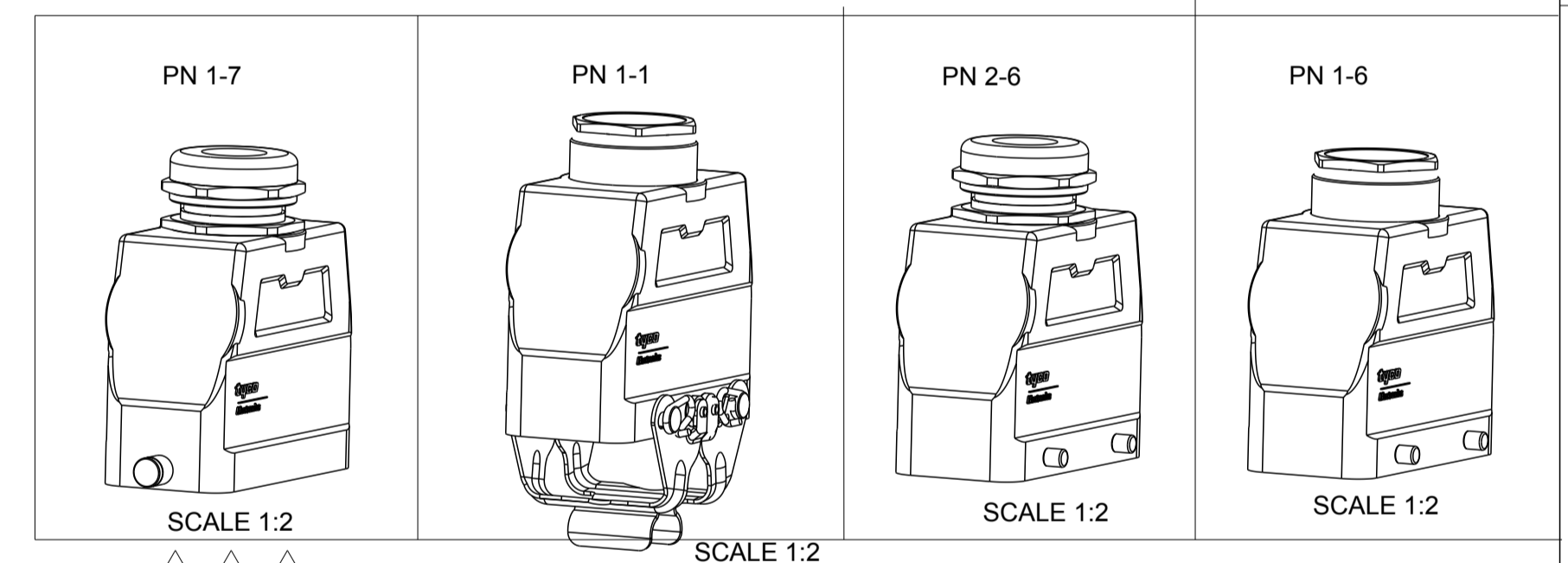
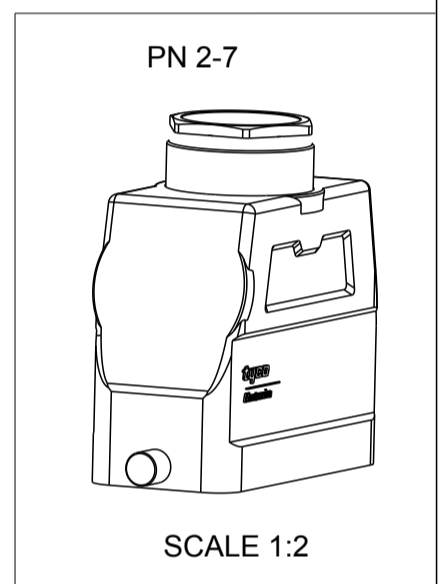
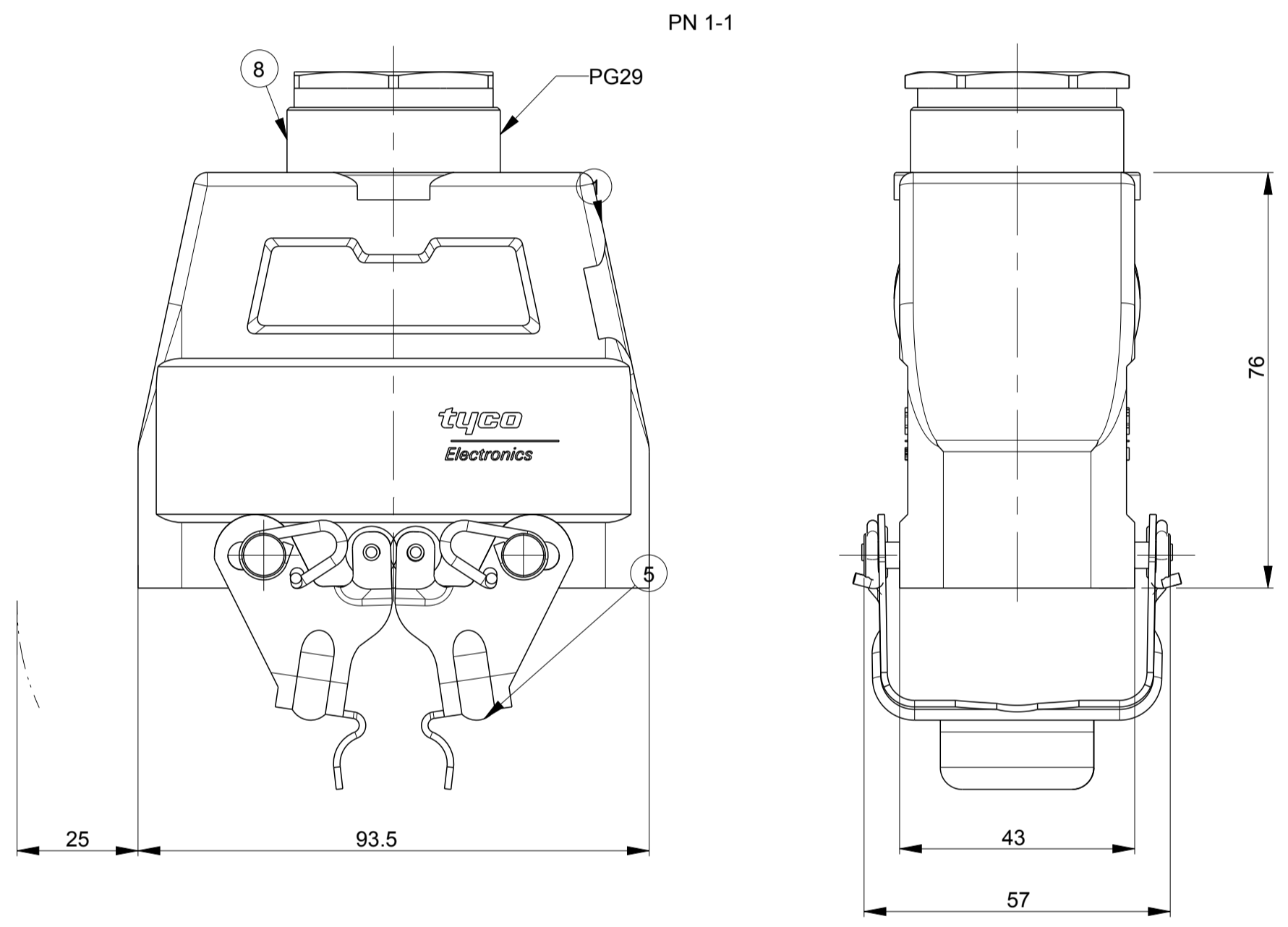
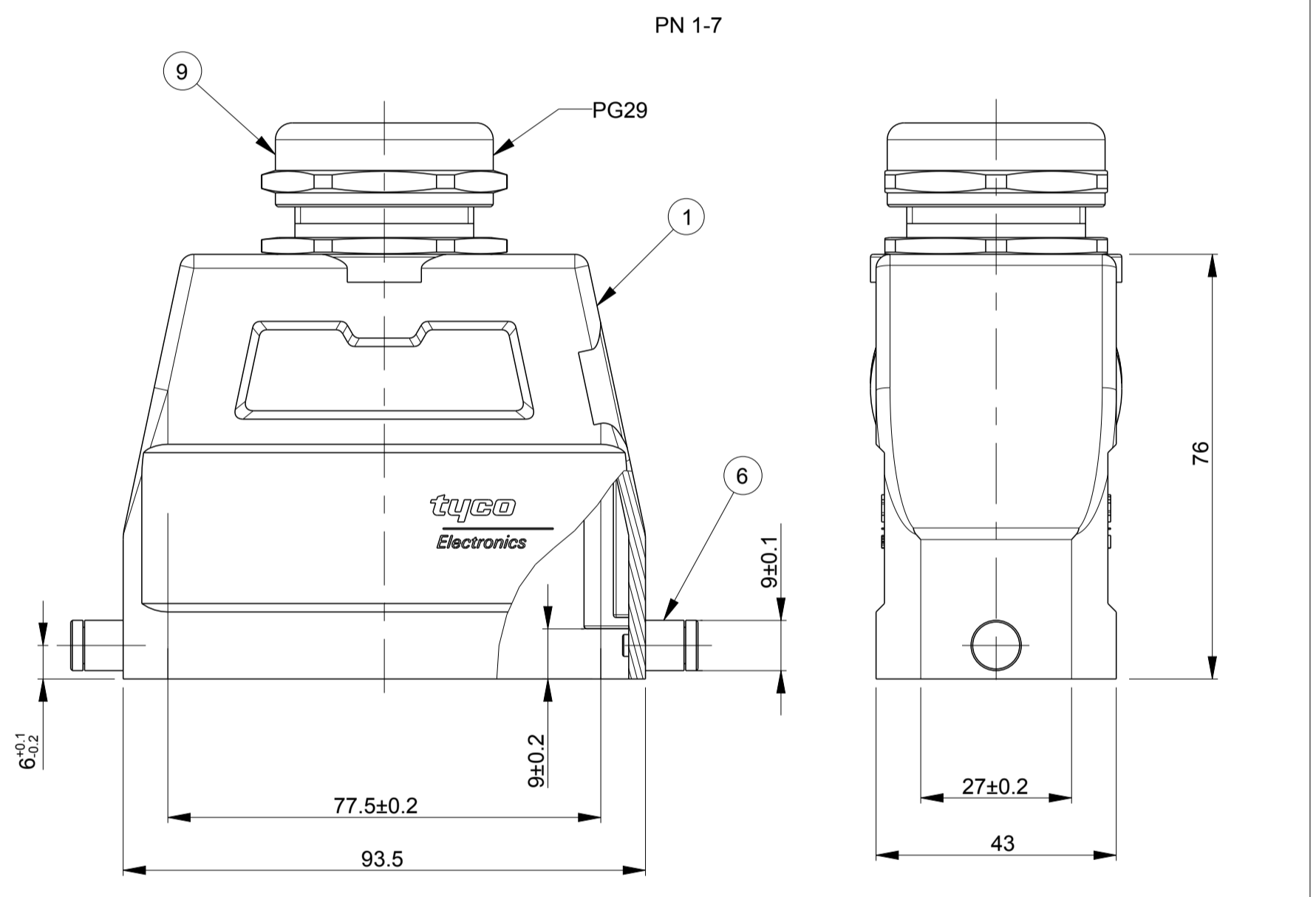
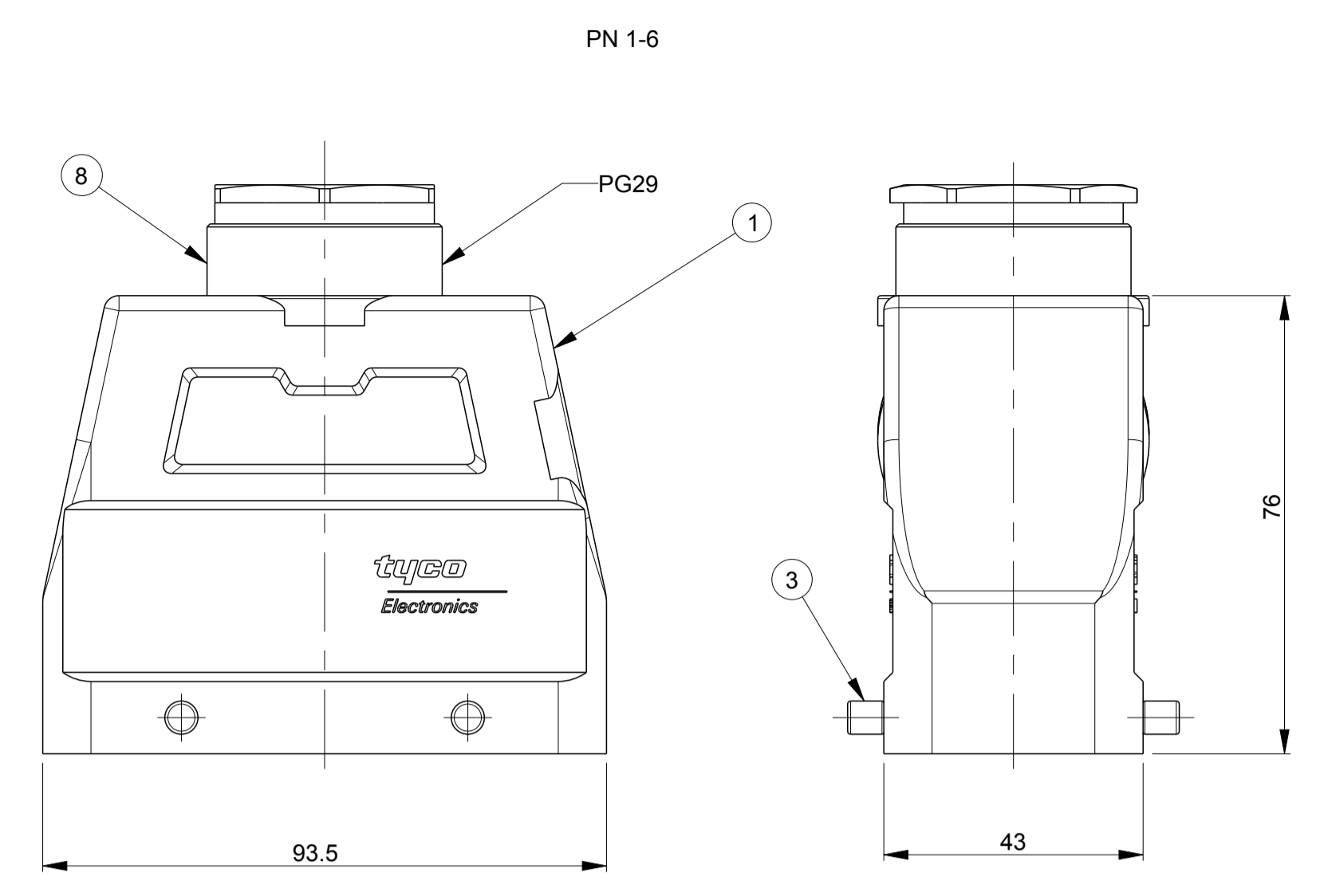
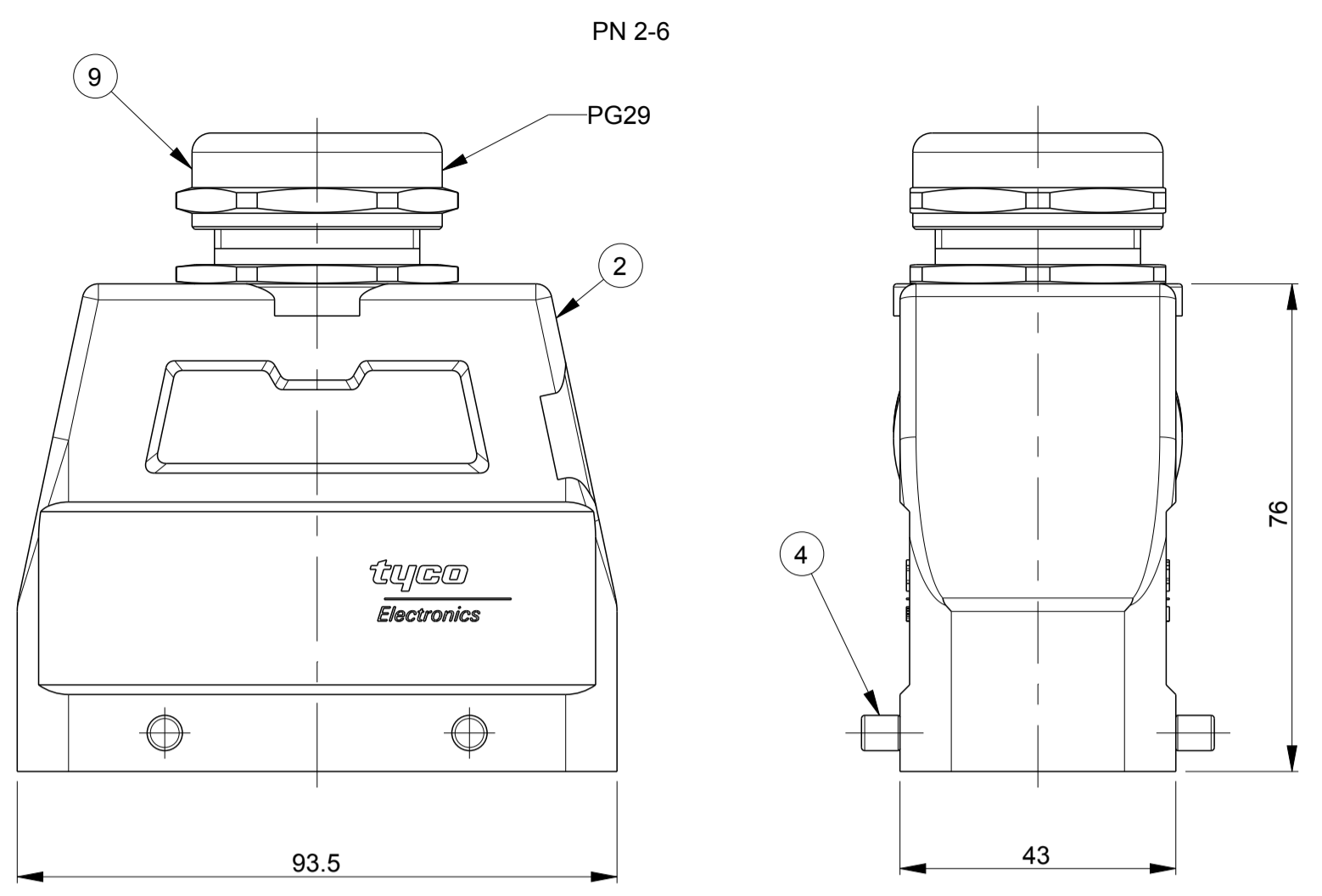

QTY	QTY	QTY	QTY	DESCRIPTION	MATERIAL	SURFACE	COLOR	ITEM NO	NOTES
1	1	1		HUT-Gland fitting PG29	Brass	Nickel plated	Blue	9	-
2	-	-	-	PG-Gland fitting PG29	Brass	Nickel plated	Blue	8	Sealed
-	-	-	-	LB-Locking clip	Stainless steel	-	-	7	-
-	2	-	-	LB-Clip bolt	Steel	Zinc plated	Blue	6	-
-	-	4	-	VS-Locking clip	Steel	Zinc plated	Blue	5	-
-	-	-	4	VS-Clip bolt	Stainless steel	-	-	4	-
-	-	-	4	VS-Clip bolt	Steel	Zinc plated	Blue	3	-
1	-	1	-	Hood HD.40.PG29	Aluminium	Aluminium oxide	Black	2	-
-	1	1	-	Hood HD.40.PG29	Aluminium	-	Grey	1	-

ORDERING TEXT

HD.40.STO.1.29

HD-K.40.STO.1.29

HD.40.STO-VS.1.29

HD.40.STO-GR.1.29

HD-K.40.STO-GR.1.29

THIS DRAWING IS A CONTROLLED DOCUMENT.

DWN: Schneider 15.03.2001
 CHK: M.Schweiger 15.03.2001

TE Connectivity

NAME: HOOD HD.40.STO.1.29

SIZE: A1 CAGE CODE: 00779 DRAWING NO: C=1102571

SCALE: 1:1 SHEET: 1 OF 1 REV: A4

CUSTOMER DRAWING