



12 Output Buffer for 2 DDR and 3 SDRAM DIMMS

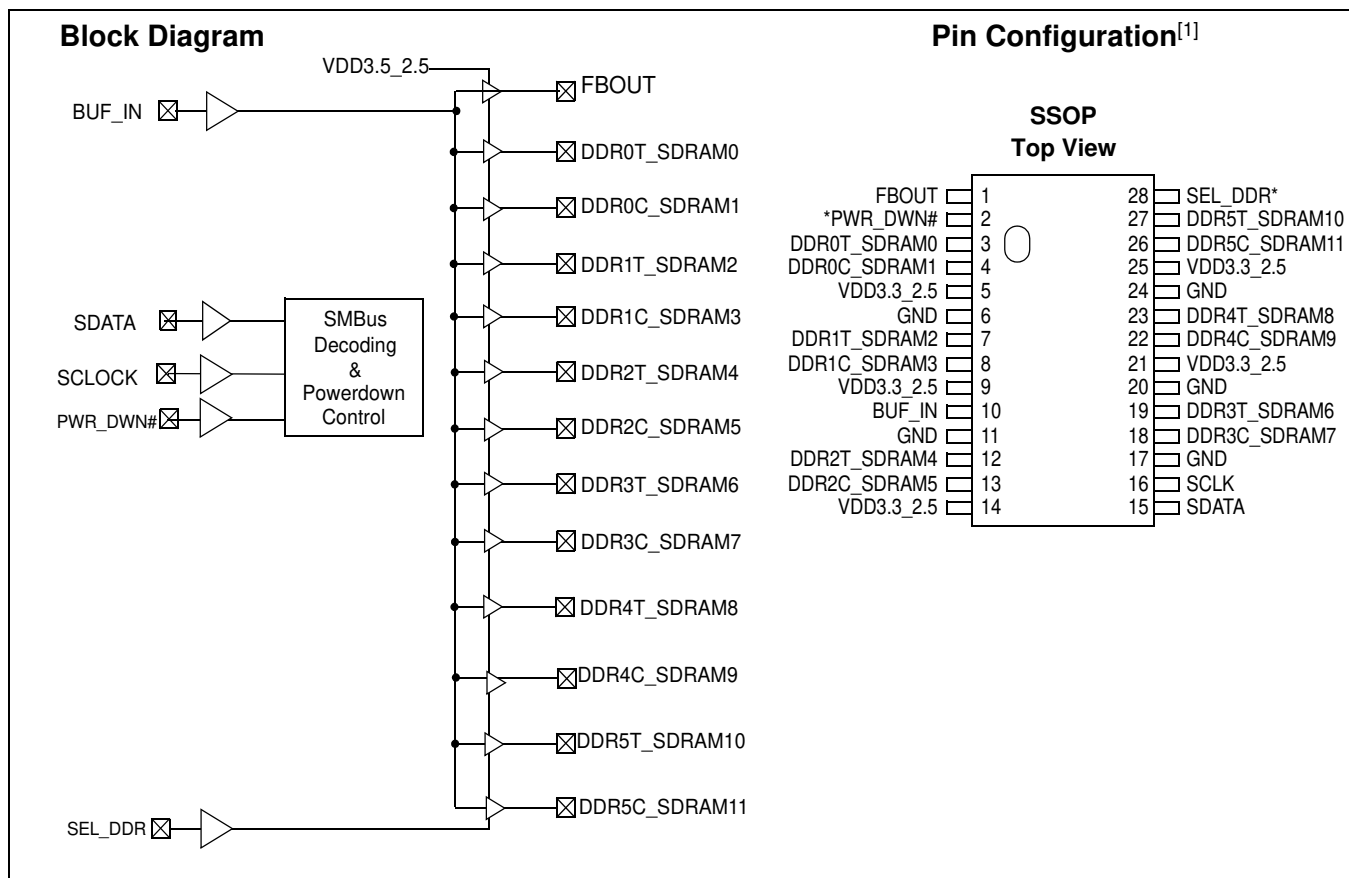
Features

- One input to 12 output buffer/drivers
- Supports up to 2 DDR DIMMs or 3 SDRAM DIMMS
- One additional output for feedback
- SMBus interface for individual output control
- Low skew outputs (< 100 ps)
- Supports 266 MHz and 333 MHz DDR SDRAM
- Dedicated pin for power management support
- Space-saving 28-pin SSOP package

Functional Description

The W256 is a 3.3V/2.5V buffer designed to distribute high-speed clocks in PC applications. The part has 12 outputs. Designers can configure these outputs to support 3 unbuffered standard SDRAM DIMMs and 2 DDR DIMMs. The W256 can be used in conjunction with the W250-02 or similar clock synthesizer for the VIA Pro 266 chipset.

The W256 also includes an SMBus interface which can enable or disable each output clock. On power-up, all output clocks are enabled (internal pull-up).



Note:

1. Internal 100K pull-up resistors present on inputs marked with *. Design should not rely solely on internal pull-up resistor to set I/O pins HIGH.

Pin Summary

Name	Pins	Description
SEL_DDR	28	Input to configure for DDR-ONLY mode or STANDARD SDRAM mode. 1 = DDR-ONLY mode. 0 = STANDARD SDRAM mode. When SEL_DDR is pulled HIGH or configured for DDR-ONLY mode, all the buffers will be configured as DDR outputs. Connect VDD3.3_2.5 to a 2.5V power supply in DDR-ONLY mode. When SEL_DDR is pulled LOW or configured for STANDARD SDRAM output, all the buffers will be configured as STANDARD SDRAM outputs. Connect VDD3.3_2.5 to a 3.3V power supply in STANDARD SDRAM mode.
SCLK	16	SMBus clock input.
SDATA	15	SMBus data input.
BUF_IN	10	Reference input from chipset. 2.5V input for DDR-ONLY mode; 3.3V input for STANDARD SDRAM mode.
FBOUT	1	Feedback clock for chipset. Output voltage depends on VDD3.3_2.5V.
PWR_DWN#	2	Active LOW input to enable Power Down mode; all outputs will be pulled LOW.
DDR[0:5]T_SDRAM [0,2,4,6,8,10]	3, 7, 12, 19, 23, 27	Clock outputs. These outputs provide copies of BUF_IN. Voltage swing depends on VDD3.3_2.5 power supply.
DDR[0:5]C_SDRAM [1,3,5,7,9, 11]	4, 8, 13, 18, 22, 26	Clock outputs. These outputs provide complementary copies of BUF_IN when SEL_DDR is active. These outputs provide copies of BUF_IN when SEL_DDR is inactive. Voltage swing depends on VDD3.3_2.5 power supply.
VDD3.3_2.5	5, 9, 14, 21, 25	Connect to 2.5V power supply when W256 is configured for DDR-ONLY mode. Connect to 3.3V power supply, when W256 is configured for standard SDRAM mode.
GND	6, 11, 17, 20, 24	Ground.

Serial Configuration Map

- The Serial bits will be read by the clock driver in the following order:
 - Byte 0 — Bits 7, 6, 5, 4, 3, 2, 1, 0
 - Byte 1 — Bits 7, 6, 5, 4, 3, 2, 1, 0
 - ...
 - Byte N — Bits 7, 6, 5, 4, 3, 2, 1, 0
- Reserved and unused bits should be programmed to "0".
- SMBus Address for the W256 is:

Table 1.

A6	A5	A4	A3	A2	A1	A0	R/W
1	1	0	1	0	0	1	—

**Byte 6: Outputs Active/Inactive Register
(1 = Active, 0 = Inactive), Default = Active**

Bit	Pin #	Description	Default
Bit 7	—	Reserved, drive to 0	0
Bit 6	—	Reserved, drive to 0	0
Bit 5	—	Reserved, drive to 0	0
Bit 4	1	FBOUT	1
Bit 3	27, 26	DDR5T_SDRAM10, DDR5C_SDRAM11	1
Bit 2	—	Reserved, drive to 0	1
Bit 1	23, 22	DDR4T_SDRAM8, DDR4C_SDRAM9	1
Bit 0	—	Reserved, drive to 0	1

**Byte 7: Outputs Active/Inactive Register
(1 = Active, 0 = Inactive), Default = Active**

Bit	Pin #	Description	Default
Bit 7	—	Reserved, drive to 0	1
Bit 6	19, 18	DDR3T_SDRAM6, DDR3C_SDRAM7	1
Bit 5	12, 13	DDR2T_SDRAM4, DDR2C_SDRAM5	1
Bit 4	—	Reserved, drive to 0	1
Bit 3	—	Reserved, drive to 0	1
Bit 2	7, 8	DDR1T_SDRAM2, DDR1C_SDRAM3	1
Bit 1	—	Reserved, drive to 0	1
Bit 0	3, 4	DDR0T_SDRAM0, DDR0C_SDRAM1	1

Maximum Ratings

Supply Voltage to Ground Potential-0.5 to +7.0V
 DC Input Voltage (except BUF_IN)-0.5V to $V_{DD}+0.5$
 Storage Temperature-65°C to +150°C
 Static Discharge Voltage>2000V
 (per MIL-STD-883, Method 3015)

Operating Conditions^[2]

Parameter	Description	Min.	Typ.	Max.	Unit
$V_{DD3.3}$	Supply Voltage	3.135		3.465	V
$V_{DD2.5}$	Supply Voltage	2.375		2.625	V
T_A	Operating Temperature (Ambient Temperature)	0		70	°C
C_{OUT}	Output Capacitance		6		pF
C_{IN}	Input Capacitance		5		pF

Electrical Characteristics Over the Operating Range

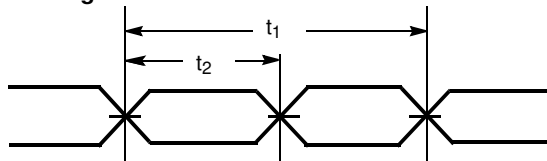
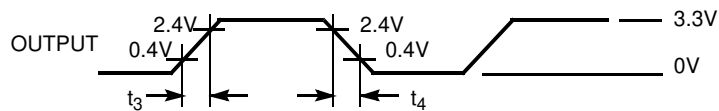
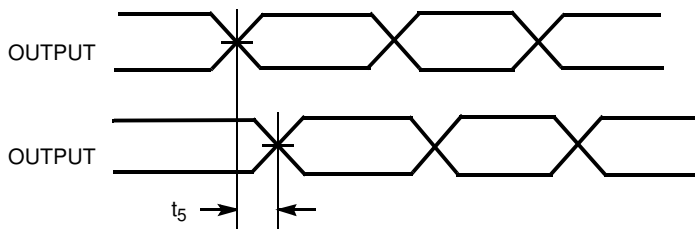
Parameter	Description	Test Conditions	Min.	Typ.	Max.	Unit
V_{IL}	Input LOW Voltage	For all pins except SMBus			0.8	V
V_{IH}	Input HIGH Voltage		2.0			V
I_{IL}	Input LOW Current	$V_{IN} = 0V$			50	μA
I_{IH}	Input HIGH Current	$V_{IN} = V_{DD}$			50	μA
I_{OH}	Output HIGH Current	$V_{DD} = 2.375V$ $V_{OUT} = 1V$	-18	-32		mA
I_{OL}	Output LOW Current	$V_{DD} = 2.375V$ $V_{OUT} = 1.2V$	26	35		mA
V_{OL}	Output LOW Voltage ^[3]	$I_{OL} = 12\text{ mA}$, $V_{DD} = 2.375V$			0.6	V
V_{OH}	Output HIGH Voltage ^[3]	$I_{OH} = -12\text{ mA}$, $V_{DD} = 2.375V$	1.7			V
I_{DD}	Supply Current ^[3] (DDR-Only mode)	Unloaded outputs, 133 MHz			400	mA
I_{DD}	Supply Current (DDR-Only mode)	Loaded outputs, 133 MHz			500	mA
I_{DDS}	Supply Current	$PWR_DWN\# = 0$			100	μA
V_{OUT}	Output Voltage Swing	See Test Circuitry (Refer to Figure 1)	0.7		$V_{DD} + 0.6$	V
V_{OC}	Output Crossing Voltage		$(V_{DD}/2) - 0.1$	$V_{DD}/2$	$(V_{DD}/2) + 0.1$	V
I_{DC}	Input Clock Duty Cycle		48		52	%

Notes:

- Multiple Supplies: The voltage on any input or I/O pin cannot exceed the power pin during power-up. Power supply sequencing is NOT required.
- Parameter is guaranteed by design and characterization. Not 100% tested in production.

Switching Characteristics^[4]

Parameter	Name	Test Conditions	Min.	Typ.	Max.	Unit
–	Operating Frequency		66		180	MHz
–	Duty Cycle ^[4,5] = $t_2 \div t_1$	Measured at 1.4V for 3.3V outputs Measured at VDD/2 for 2.5V outputs.	I_{NDC} –5%		$I_{NDC} + 5\%$	%
t_3	SDRAM Rising Edge Rate ^[4]	Measured between 0.4V and 2.4V	1.0		2.50	V/ns
t_4	SDRAM Falling Edge Rate ^[4]	Measured between 2.4V and 0.4V	1.0		2.50	V/ns
t_{3d}	DDR Rising Edge Rate ^[4]	Measured between 20% to 80% of output (Refer to <i>Figure 1</i>)	0.5		1.50	V/ns
t_{4d}	DDR Falling Edge Rate ^[4]	Measured between 20% to 80% of output (Refer to <i>Figure 1</i>)	0.5		1.50	V/ns
t_5	Output to Output Skew ^[4]	All outputs equally loaded			100	ps
t_6	Output t4o Output Skew for SDRAM ^[2]	All outputs equally loaded			150	ps
t_7	SDRAM Buffer HH Prop. Delay ^[4]	Input edge greater than 1 V/ns	5		10	ns
t_8	SDRAM Buffer LL Prop. Delay ^[4]	Input edge greater than 1 V/ns	5		10	ns

Switching Waveforms
Duty Cycle Timing

All Outputs Rise/Fall Time

Output-Output Skew

Notes:

4. All parameters specified with loaded outputs.
5. Duty cycle of input clock is 50%. Rising and falling edge rate is greater than 1V/ns.

Switching Waveforms (continued)

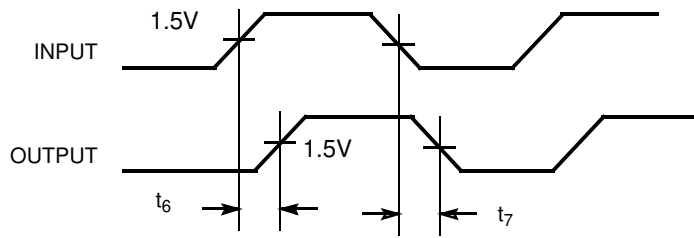
SDRAM Buffer HH and LL Propagation Delay


Figure 1 shows the differential clock directly terminated by a $120\ \Omega$ resistor.

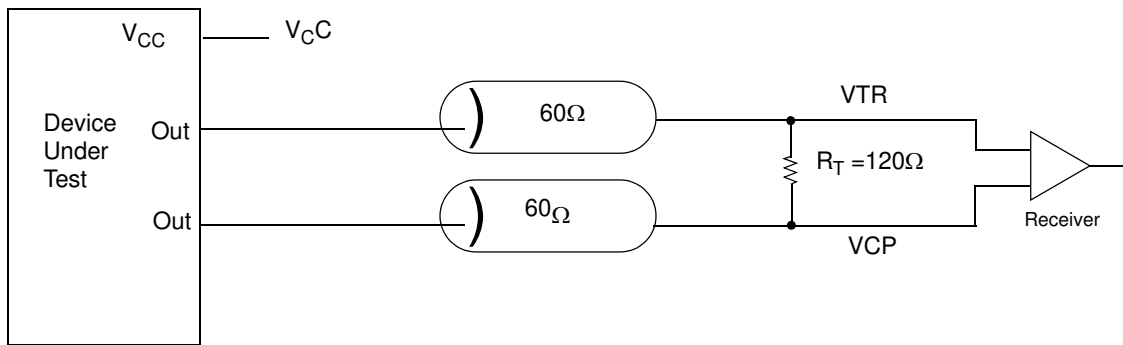
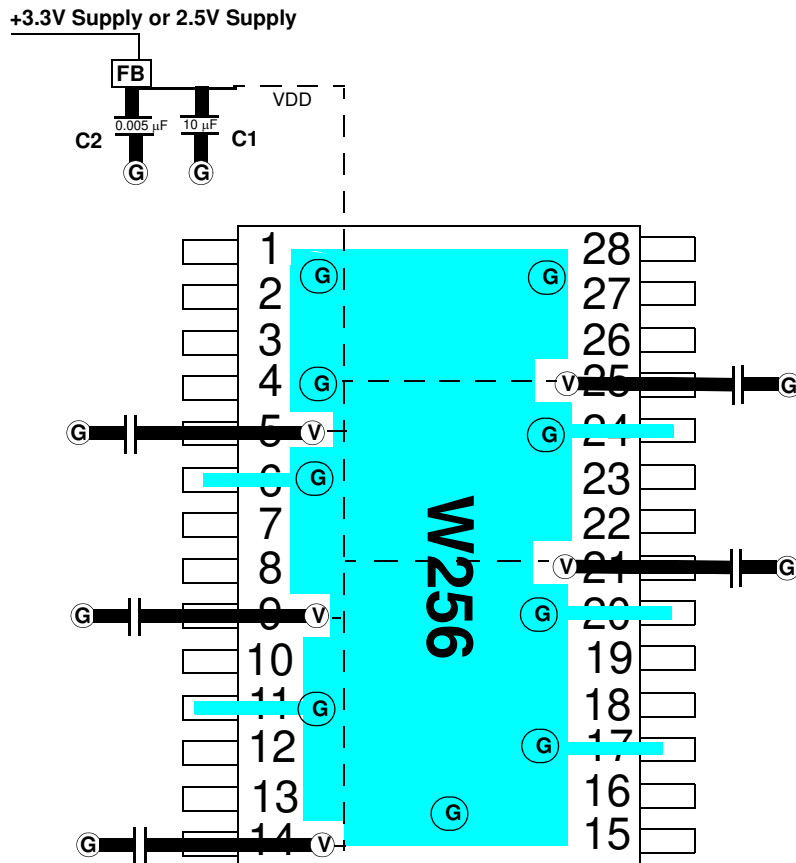


Figure 1. Differential Signal Using Direct Termination Resistor

Layout Example Single Voltage


FB = Dale ILB1206 – 300 (300Ω @ 100 MHz)

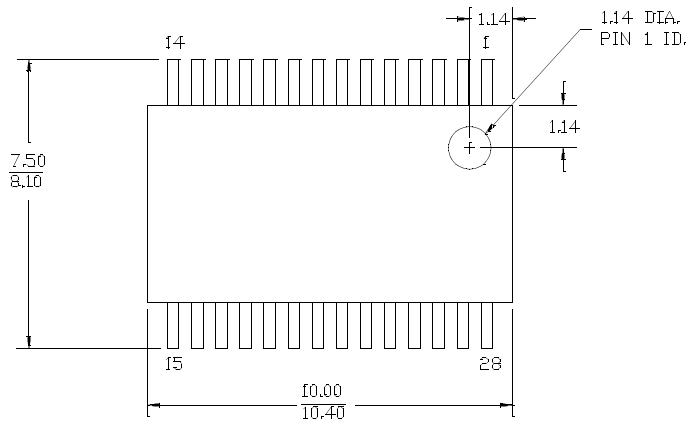
Ceramic Caps C1 = 10–22 μF C2 = 0.005 μF

ⓐ = VIA to GND plane layer Ⓥ = VIA to respective supply plane layer

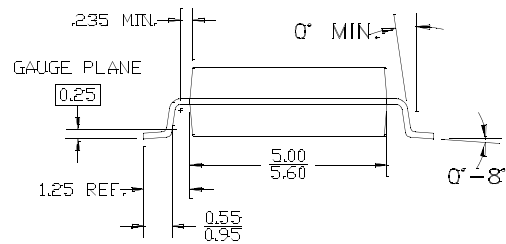
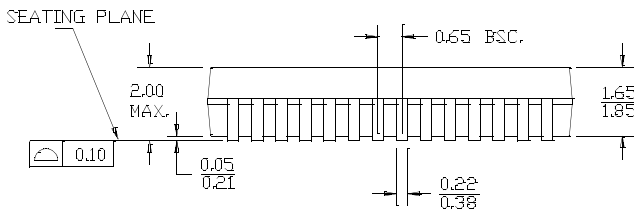
**Note: Each supply plane or strip should have a ferrite bead and capacitors
All bypass caps = 0.1 μF ceramic**

Ordering Information

Ordering Code	Package Type	Operating Range
W256H	28-pin SSOP	Commercial
W256HT	28-pin SSOP – Tape and Reel	Commercial
Lead Free		
CYW256OXC	28-pin SSOP	Commercial
CYW256OXCT	28-pin SSOP – Tape and Reel	Commercial

Package Drawings and Dimension
28-Lead (5.3 mm) Shrunk Small Outline Package O28


DIMENSIONS IN MILLIMETERS MIN. MAX.



51-85079-°C

Document History Page

Document Title: W256 12 Output Buffer for 2 DDR and 3 SRAM DIMMS
Document Number: 38-07256

REV.	ECN NO.	Issue Date	Orig. of Change	Description of Change
**	110521	12/04/01	SZV	Change from Spec number: 38-01083 to 38-07256
*A	112153	03/01/02	IKA	Added 333 MHz for SDRAM
*B	122858	12/19/02	RBI	Added power requirements to operating conditions information.
*C	258671	See ECN	RGL	Added Lead Free Devices