

RQRA-1600-LC

ELECTRICAL SPECIFICATIONS

PARAMETER	CONDITION	SYMBOL	VALUE			UNIT
			Min.	Typ.	Max.	
Frequency Range	Vt=0 ~5.0V	fo(Vt)		1600		MHz
Power Supply Voltage	±5%	Vcc		8.0		V
Tuning Voltage		Vt	0.0		5.0	V
Supply Current	Vcc=8.0V ±5%	Icc			20	mA
Tuning Sensitivity	Vt=0~5V Vcc=8.0V ±5% T=25°C	df/dVt	1.0			MHz/V
Pushing	Vcc ±5%	df/dVcc		4.0		MHz-pk-pk
Pulling ^{1,2}	Return Loss: 12dB	df/dZL		3.5		
Operating Temperature		Ta	-20		85	°C
Storage Temperature		Tstor	-40		85	°C
Maximum Limits Voltage	V _{cc(abs)}		-0.4		10	V
Moisture Sensitivity Level	MSL	JEDEC J-STD-2	1			
Termination; Finish			Glass-reinforced laminate base and nickel-silver cover			
ESD Sensitivity	HBM	Human body model JESD22-A114		3		kV

SINE-WAVE	PARAMETER	SYMBOL	CONDITION	VALUE			UNIT
				Min	Typ.	Max	
	Output Power	Pw	Output termination 50Ω Vcc=8.0V ±5%		0	5	dBm
	2nd Harmonic Suppression	h ²			-15	-10	dBc
	3rd Harmonic Suppression	h ³			-20	-10	dBc
	Spurious (Non-Harmonic)	Sp				-80	dBc
	Output Load	O _{CL}		50		Ω	

RQRA-1600-LC

MECHANICAL DIMENSIONS AND PIN FUNCTIONING

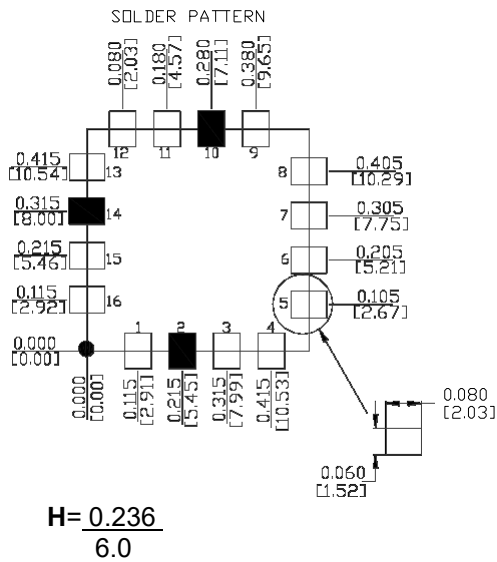
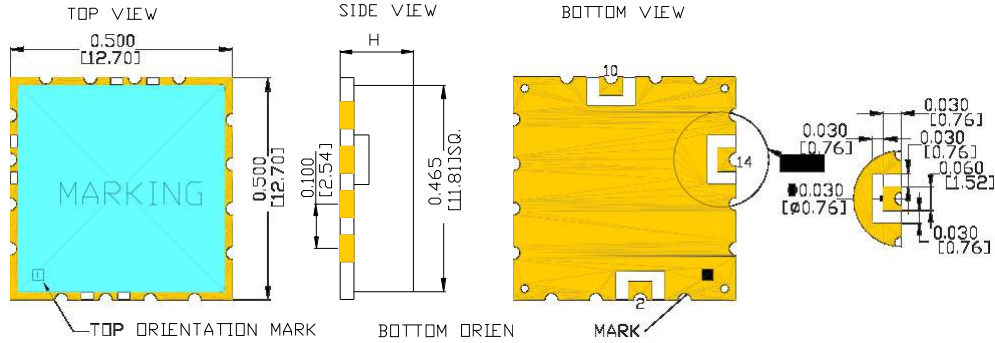

GOLD FINISH

PAD	CONNECTION
2	VT
10	RF-OUTPUT
14	Vcc
OTHERS	GROUND

DIMENSIONS ARE IN: Inches [mm]

H Tolerance: ± 0.020 in
 ± 0.51 mm

■ Marking:

RQRA
1600-LC
Date code

RQRA-1600-LC



PARAMETER	SYMBOL	CONDITION	VALUE			UNIT
			Min	Typ	Max	
SSB Phase noise	$\Sigma(\Delta f)$	$\Delta f=1.0\text{kHz}$		-90		dBc
		$\Delta f=10.0\text{kHz}$		-120		
		$\Delta f=100\text{kHz}$		-135		
		$\Delta f=1.0\text{MHz}$		-155		
		$\Delta f=10.0\text{MHz}$		-165		
Phase Jitter	1Φ	1.0KHz~1.0MHz		0.10	0.15	ps rms

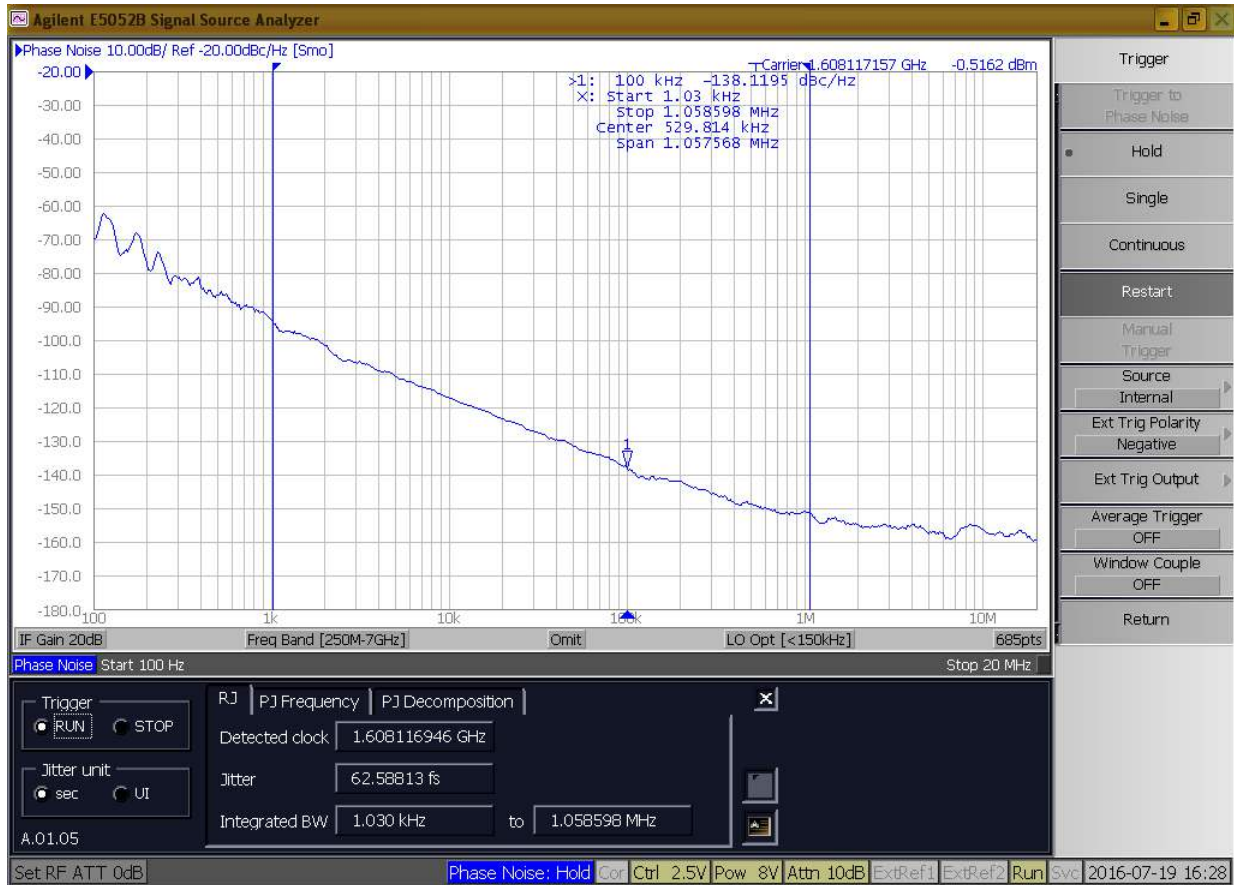

RQRA-1600-LC

- 
- 1.1 -Load impedance is 50 Ohms.
 - 1.2 -Pulling is measured with 12dB return loss, all phases.
 - 1.3- Package outline tolerances are typ. $\pm 0.30\text{mm}$ / ± 0.012 inch if not stated differently on the drawing.
 - 1.4 -It is recommended to provide two bypass-capacitors (ceramic), from Vcc to Gnd, $1\text{nF} \parallel 100\text{pF}$.
 - 1.5- Solder temperature (peak) is 260°C for 10-20s.



PARAMETER	CONDITIONS
Mechanical Shock	MIL-STD-883, Method 2002
Mechanical Vibration	MIL-STD-883, Method 2007
Solderability	MIL-STD-883, Method 2003
Resistance to Solvents	MIL-STD-883, Method 2016

RQRA-1600-LC

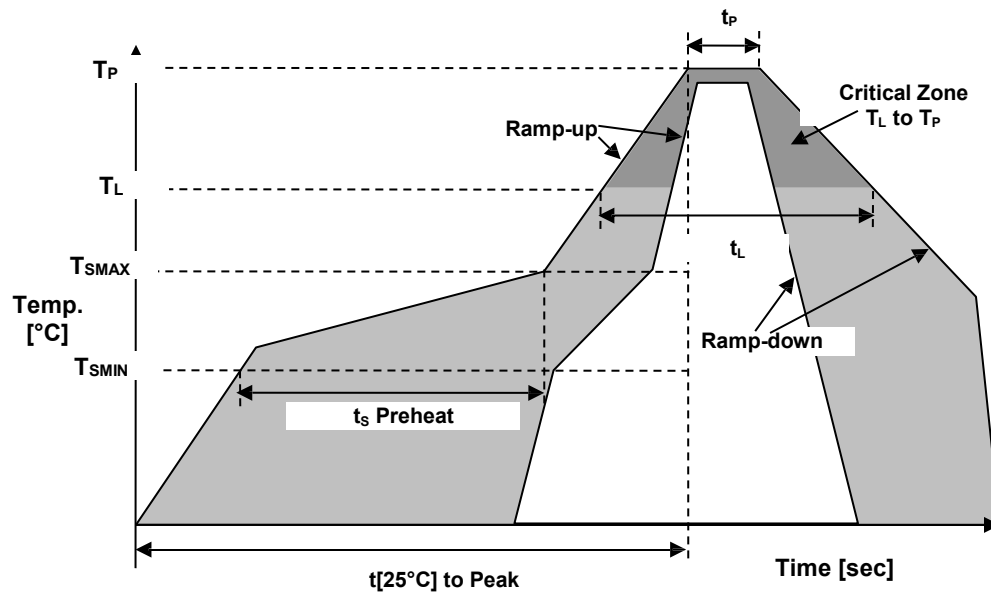

Recommended Solder Reflow Profile			
Temperature Min Preheat	T_{SMIN}		150°C
Temperature Max Preheat	T_{SMAX}		175°C
Time (T_{SMIN} to T_{SMAX})	t_s		60-180 sec.
Temperature	T_L		217°C
Peak Temperature	T_P		260°C
Ramp-up rate	R_{UP}		3°C/sec max.
Ramp-down rate	R_{DOWN}		6°C/sec max.
Time within 5°C of Peak Temperature	t_p		10-20 sec max.
Time $t[25^\circ\text{C}]$ to Peak Temperature	$t[25^\circ\text{C}] \text{ to Peak}$		480 sec.
Time	t_L		60-150 sec.

APPROVALS

Eng. approval, date: IM 01/31/2019

Created by, date: AR 01/31/2019

Revision: A

