

SPECIFICATIONS



Part Number: 19032038A
Model Number: MD48B3

February 12, 2004

Mechanical Drawing:

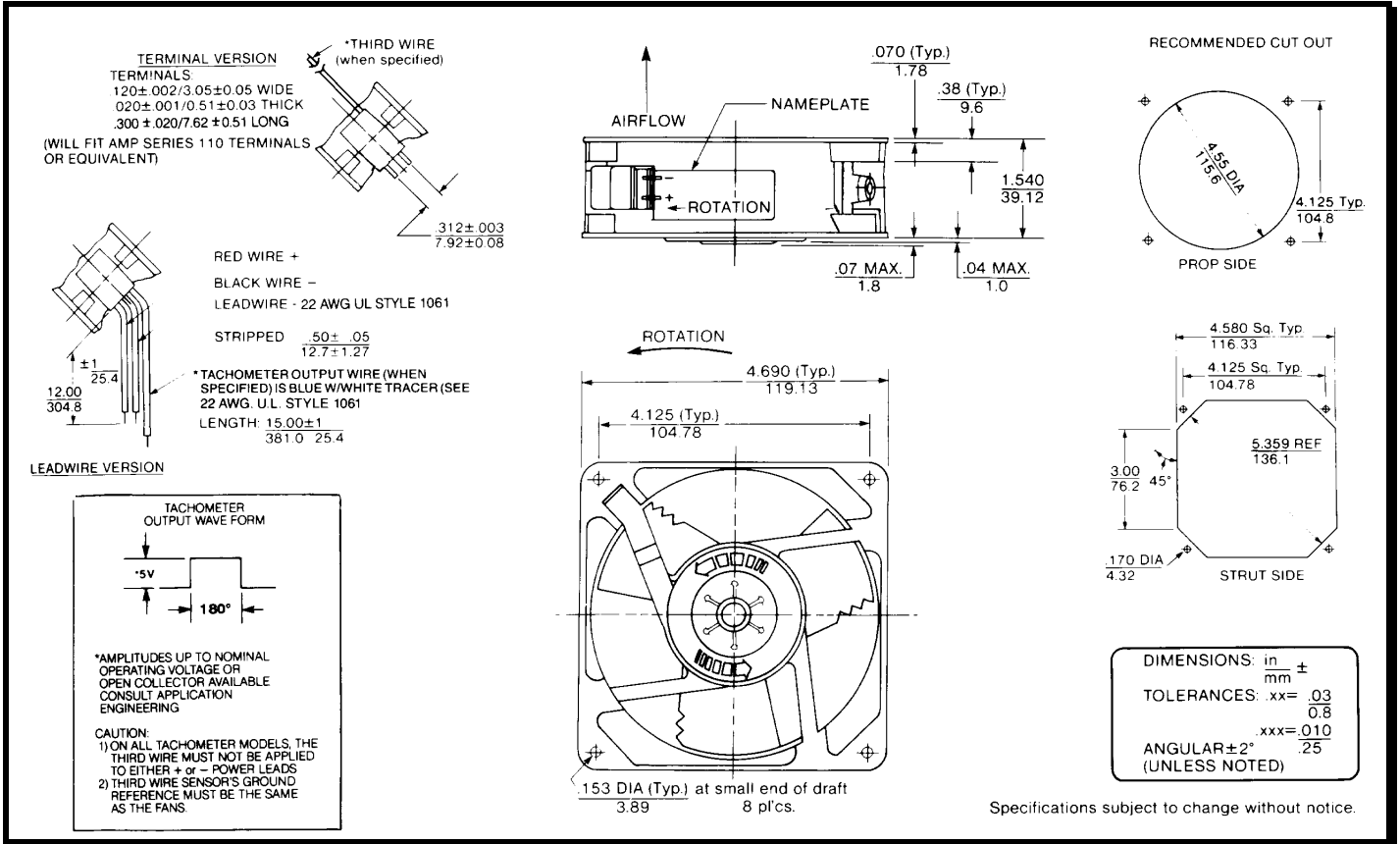

Motor:

Nominal Voltage = 48 vdc
 Operating Voltage Range = 24 - 56 vdc
 Nominal Running Current = 0.120 amps
 Locked Rotor Current = 0.400 amps
 Running Power = 5.8 watts
 Average Speed = 3100 rpm
 Bearings = Ball
 Air Flow = 110 CFM
 Acoustic = 50.0 dBA

Construction:

Venturi: Die-Cast Zinc Alloy, Black
 Propeller: Plastic, Black, UL 94V-0

Agency Certifications:

UL, CE

Life Expectancy:

This fan is designed for continuous duty life of 83,000 hours at 40°C.

Additional Features:

Brushless DC Motor
 Automatic Restart Capability
 Locked Rotor Protection
 Polarity Protected
 Operating Temperature: -10°C to 70°C
 Storage Temperature: -40°C to 85°C

Termination:

12" Lead wires, 22 AWG, UL 1061
 Red = Power (+)
 Black = Return (-)