



IS314P



DESCRIPTION

The IS314P Photocoupler is ideally suited for driving power IGBTs and MOSFETs used in inverters of motor control and of power supply system. It contains an AlGaAs LED optically coupled to an integrated circuit with a power output stage.

The device is in Stretched SO6 package.

FEATURES

- 1.0A Maximum Peak Output Current
- 0.8A Minimum Peak Output Current
- Rail-to-Rail output voltage
- 20kV/ μ s Minimum Common Mode Rejection at V_{CM} 1500V
- Maximum Propagation Delay 200ns
- Maximum Propagation Delay Difference 100ns
- Wide Operating Voltage Range V_{CC} 10 to 30 V
- Maximum Supply Current I_{CC} 3.0mA
- Under Voltage Lock Out (UVLO) Protection with Hysteresis
- Guaranteed Performance over Temperature Range - 40°C to +105°C
- MSL Level 1
- Lead Free and RoHS Compliant
- Safety Approvals Pending

APPLICATIONS

- IGBT/MOSFET Gate Drive
- UPS
- Inverters
- Switching Power Supplies
- AC Brushless and DC Motor Drives

ORDER INFORMATION

- Supplied in Tape & Reel

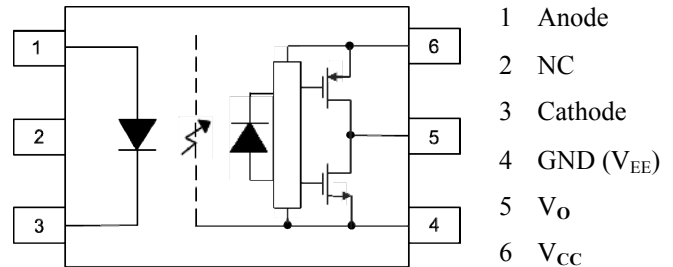

A 0.1 μ F bypass Capacitor must be connected between Pins 6 and 4.

ABSOLUTE MAXIMUM RATINGS ($T_A = 25^\circ\text{C}$)

Stresses exceeding the absolute maximum ratings can cause permanent damage to the device.

Exposure to absolute maximum ratings for long periods of time can adversely affect reliability.

Input

Forward Current	25mA
Forward Peak Current (Pulse Width $\leq 1\mu$ s, 300pps)	1.0A
Reverse Voltage	5V
Forward Current Rise / Fall Time	500ns
Power dissipation	45mW

Output

High Level Peak Output Current Exponential waveform. Pulse width $\leq 0.3\mu$ s, $f \leq 15$ kHz	1.0A
Low Level Peak Output Current Exponential waveform. Pulse width $\leq 0.3\mu$ s, $f \leq 15$ kHz	1.0A
Supply Voltage ($V_{CC} - V_{EE}$)	35V
Output Voltage	V_{CC}
Power Dissipation	250mW

Total Package

Isolation Voltage	5000V _{RMS}
Total Power Dissipation	295mW
Operating Temperature	-40 to 105 °C
Storage Temperature	-55 to 125 °C
Lead Soldering Temperature (10s)	260°C

ISOCOM COMPONENTS 2004 LTD

Unit 25B, Park View Road West, Park View Industrial Estate
Hartlepool, Cleveland, TS25 1PE, United Kingdom
Tel : +44 (0)1429 863 609 Fax : +44 (0)1429 863 581
e-mail : sales@isocom.co.uk
<http://www.isocom.com>

ISOCOM COMPONENTS ASIA LTD

Hong Kong Office,
Block A, 8/F, Wah Hing Industrial mansion,
36 Tai Yau Street, San Po Kong, Kowloon, Hong Kong.
Tel : +852 2995 9217 Fax : +852 8161 6292
e-mail : sales@isocom.com.hk



IS314P

Truth Table

LED	High Side	Low Side	V _o
OFF	OFF	ON	LOW
ON	ON	OFF	HIGH

Recommended Operating Conditions

Parameter	Symbol	Min	Max	Unit
Operating Temperature	T _A	- 40	105	°C
Supply Voltage	V _{CC} - V _{EE}	10	30	V
Input Current (ON)	I _{F(ON)}	7	16	mA
Input Voltage (OFF)	V _{F(OFF)}	-3.0	0.8	V



IS314P

ELECTRICAL CHARACTERISTICS (Typical Values at $V_{CC} - V_{EE} = 10V$ to $30V$ and $T_A = 25^\circ C$,
Minimum and Maximum Values at Recommended Operating Conditions,
unless otherwise specified)

INPUT

Parameter	Symbol	Test Condition	Min	Typ.	Max	Unit
Forward Voltage	V_F	$I_F = 10mA$	1.2	1.37	1.8	V
Forward Voltage Temperature Coefficient	$\Delta V_F / \Delta T$	$I_F = 10mA$		-1.237		mV/°C
Reverse Voltage	V_R	$I_R = 10\mu A$	5			V
Input Threshold Current (Low to High)	I_{FLH}	$V_O > 5V, I_O = 0A$		1.9	5	mA
Input Threshold Voltage (High to Low)	V_{FHL}	$V_O < 5V, I_O = 0A$	0.8			V
Input Capacitance	C_{IN}	$V_F = 0V, f = 1MHz$		33		pF

OUTPUT

Parameter	Symbol	Test Condition	Min	Typ.	Max	Unit
High Level Supply Current	I_{CCH}	$I_F = 7$ to $16mA$ $V_O = \text{Open}$		1.9	3.0	mA
Low Level Supply Current	I_{CCL}	$V_F = -3$ to $0.8V$ $V_O = \text{Open}$		2.1	3.0	mA
High Level Output Current	I_{OH}	$V_O = V_{CC} - 1.5V$ Pulse Width = $50\mu s$			-0.3	A
		$V_O = V_{CC} - 3V$ Pulse Width = $10\mu s$			-0.8	
Low Level Output Current	I_{OL}	$V_O = V_{EE} + 1.5V$ Pulse Width = $50\mu s$	0.3			A
		$V_O = V_{EE} + 3V$ Pulse Width = $10\mu s$	0.8			
High Level Output Voltage	V_{OH}	$I_F = 10mA, I_O = -100mA$	$V_{CC} - 0.6$	$V_{CC} - 0.35$		V
Low Level Output Voltage	V_{OL}	$I_F = 0mA, I_O = 100mA$		$V_{EE} + 0.25$	$V_{EE} + 0.4$	V
UVLO Threshold	V_{UVLO+}	$V_O > 5V, I_F = 10mA$		7.8		V
	V_{UVLO-}	$V_O < 5V, I_F = 10mA$		6.7		V
UVLO Hysteresis	$UVLO_{HYS}$			1.1		V



IS314P

ELECTRICAL CHARACTERISTICS (Typical Values at $V_{CC} - V_{EE} = 10V$ to $30V$ and $T_A = 25^\circ C$,
Minimum and Maximum Values at Recommended Operating Conditions,
unless otherwise specified)

SWITCHING

Parameter	Symbol	Test Condition	Min	Typ.	Max	Unit
Propagation Delay Time to High Output Level	t_{PLH}	$I_F = 7$ to $16mA$, $V_{CC} = 15$ to $30V$, $V_{EE} = 0V$ $R_g = 47\Omega$, $C_g = 3nF$, $f = 10kHz$, Duty Cycle = 50%	50	120	200	ns
Propagation Delay Time to Low Output Level	t_{PHL}		50	110	200	
Pulse Width Distortion $ t_{PHL} - t_{PLH} $ for any given device	PWD			20	70	
Propagation Delay Difference ($t_{PHL} - t_{PLH}$) between any two Devices	PDD		-100		100	
Output Rise Time (10% to 90%)	t_r				35	
Output Fall Time (90% to 10%)	t_f				35	
Common Mode Transient Immunity at High Output Level	CM_H	$I_F = 10$ to $16mA$, $V_{CC} = 30V$ $V_{CM} = 1500V$, $T_A = 25^\circ C$	20	25		kV/ μs
Common Mode Transient Immunity at Low Output Level	CM_L	$V_F = 0V$, $V_{CC} = 30V$ $V_{CM} = 1500V$, $T_A = 25^\circ C$	20	25		kV/ μs



IS314P

ELECTRICAL CHARACTERISTICS (Typical Values at $V_{CC} - V_{EE} = 10V$ to $30V$ and $T_A = 25^\circ C$,
Minimum and Maximum Values at Recommended Operating Conditions,
unless otherwise specified)

ISOLATION

Parameter	Symbol	Test Condition	Min	Typ.	Max	Unit
Insulation Voltage	V_{ISO}	$RH \leq 40\%$ to 60% , $t = 1 \text{ min}$, $T_A = 25^\circ C$	5000			V
Input - Output Resistance	R_{I-O}	$V_{I-O} = 500VDC$		10^{12}		Ω
Input - Output Capacitance	C_{I-O}	$f = 1MHz$, $T_A = 25^\circ C$		0.92		pF

Note :

1. A 0.1uF or bigger bypass capacitor must be connected across pin 6 and pin 4.
2. PDD is the difference of t_{PHL} and t_{PLH} between any two IS314P devices under same test conditions.
3. CM_H , Common Mode Transient Immunity in High stage is the maximum tolerable positive dV_{CM}/dt on the leading edge of the common mode impulse signal, V_{CM} , to assure that the output will remain high ($V_O > 15V$).
4. CM_L , Common Mode Transient Immunity in Low stage is the maximum tolerable negative dV_{CM}/dt on the trailing edge of the common mode impulse signal, V_{CM} , to assure that the output will remain low ($V_O < 1V$).



IS314P

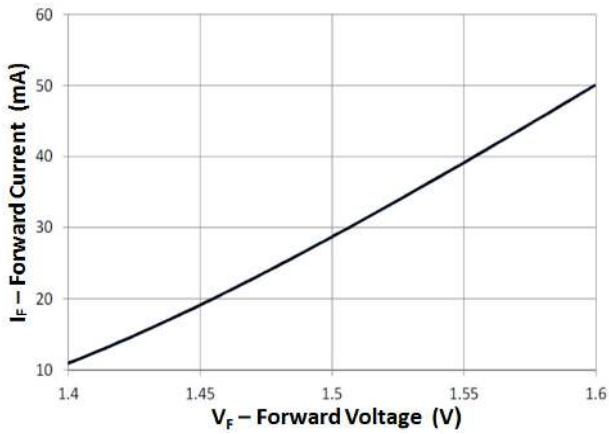

Fig 1 Forward Current vs Forward Voltage

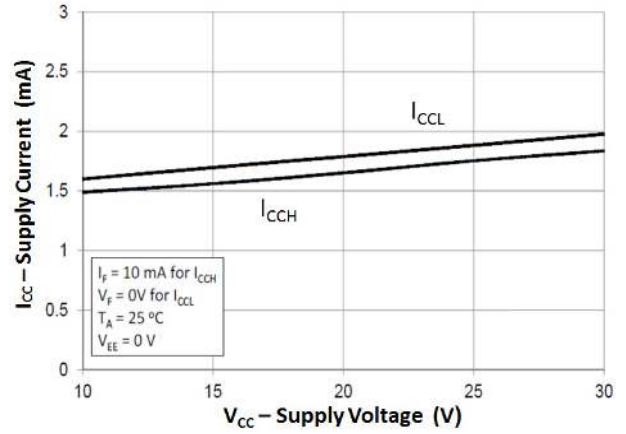

Fig 2 Supply Current vs Supply Voltage

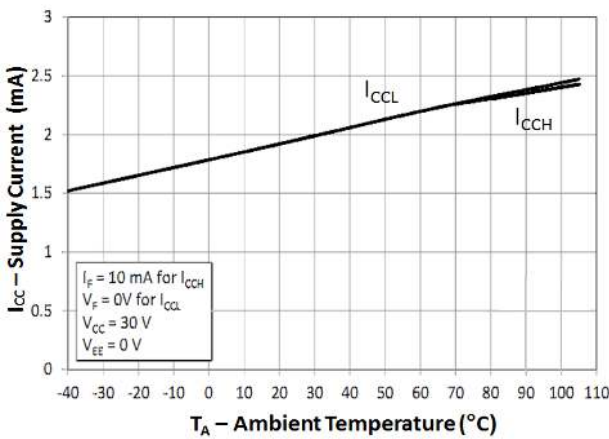

Fig 3 Supply Current vs Ambient Temperature

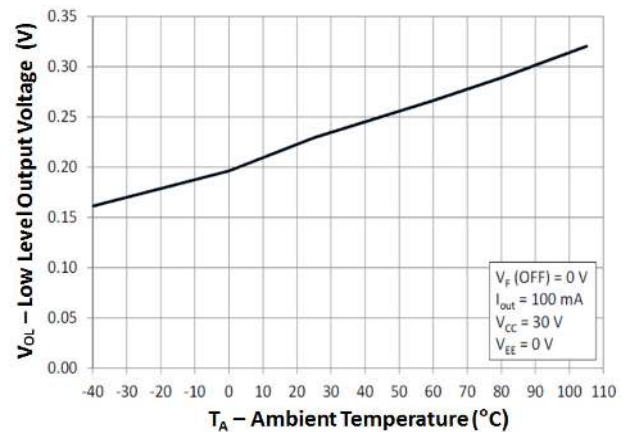

Fig 4 Low Level Output Voltage vs Ambient temperature

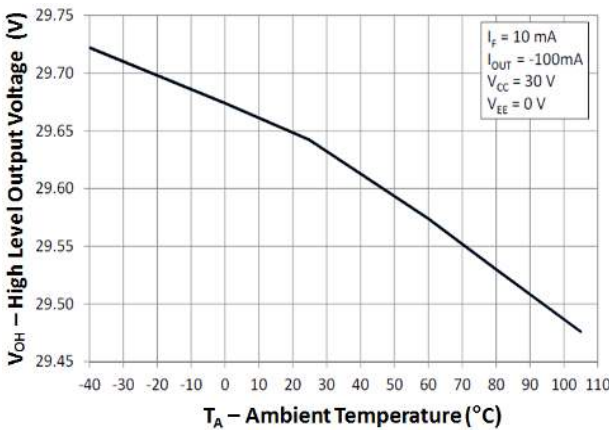

Fig 5 High Level Output Voltage vs Ambient Temperature

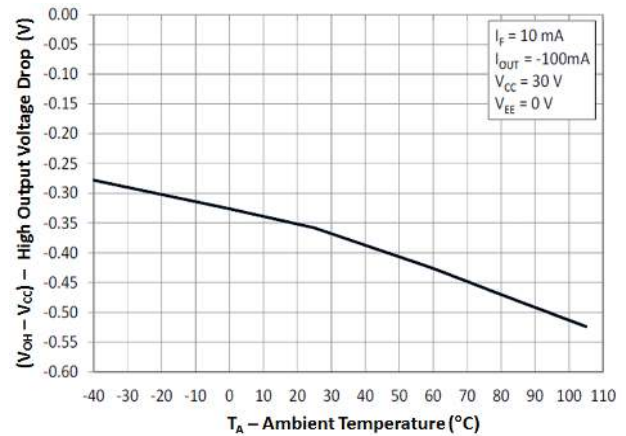

Fig 6 High Output Voltage Drop vs Ambient Temperature



IS314P

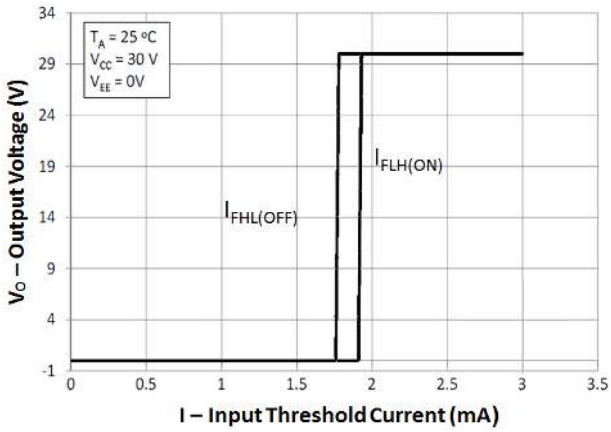

Fig 7 I_{FLH} Hysteresis

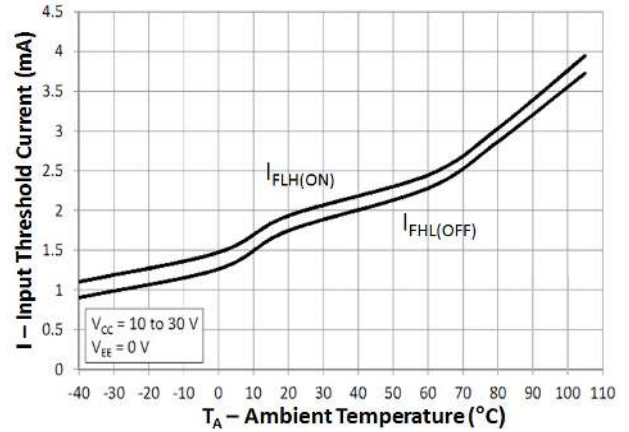

Fig 8 Input Threshold Current vs Ambient Temperature

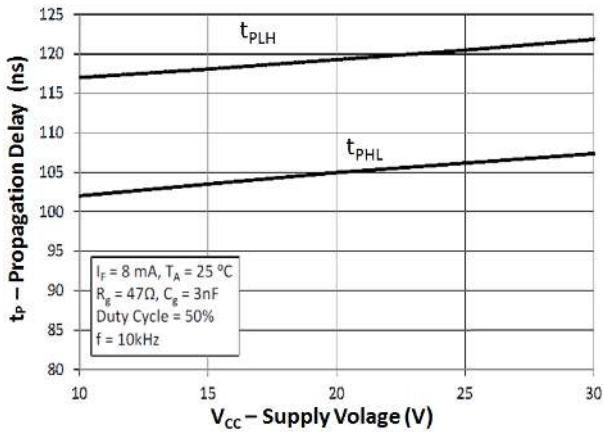

Fig 9 Propagation Delay vs Supply Voltage

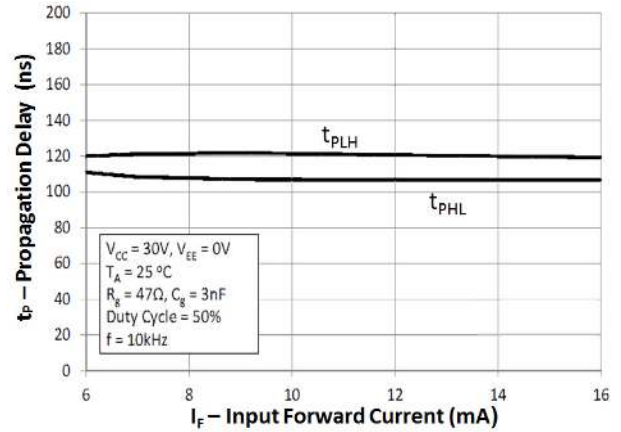

Fig 10 Propagation Delay vs Forward Current

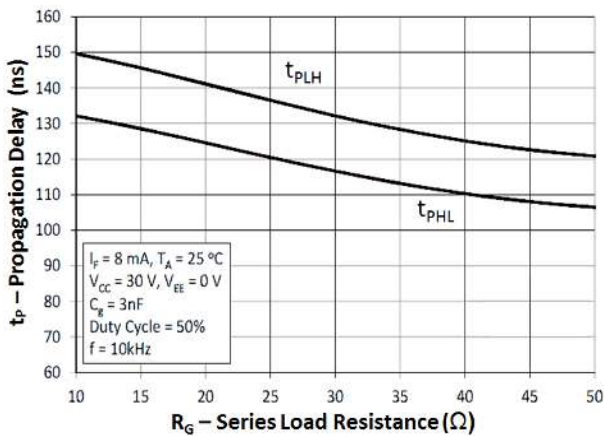

Fig 11 Propagation Delay vs Series Load Resistance

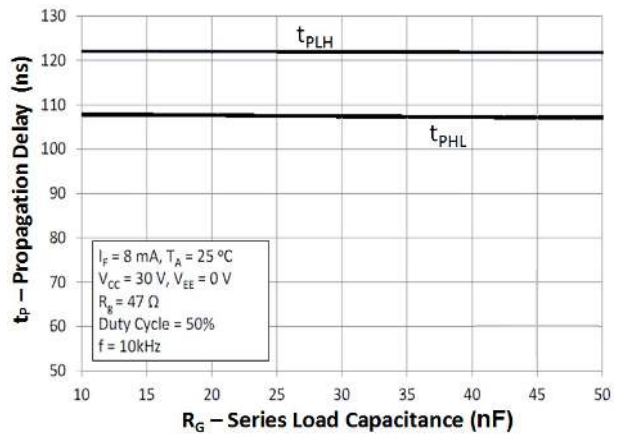

Fig 12 Propagation Delay vs Series Load Capacitance



IS314P

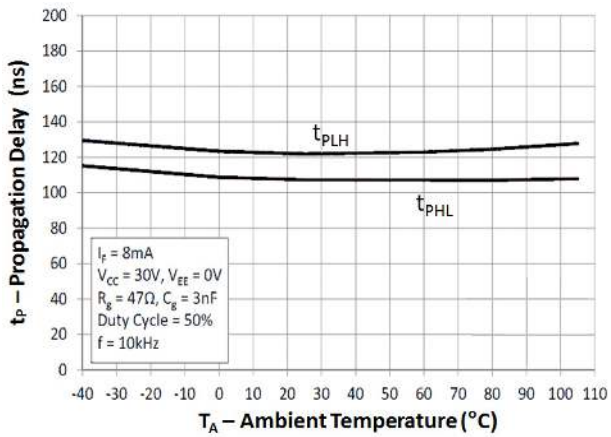
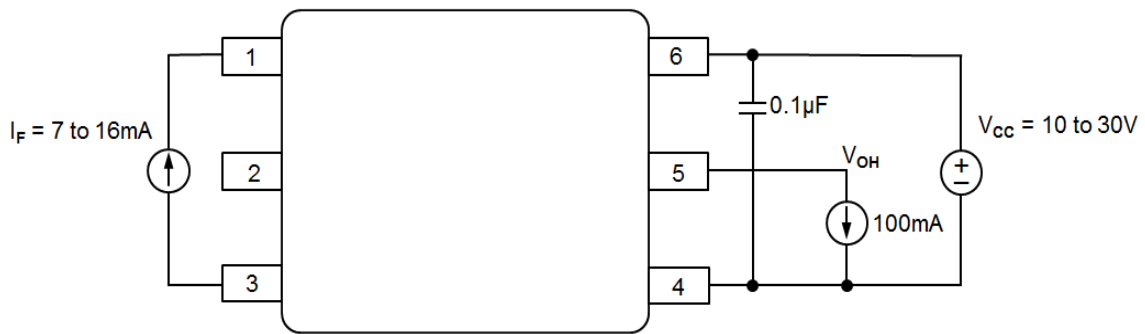
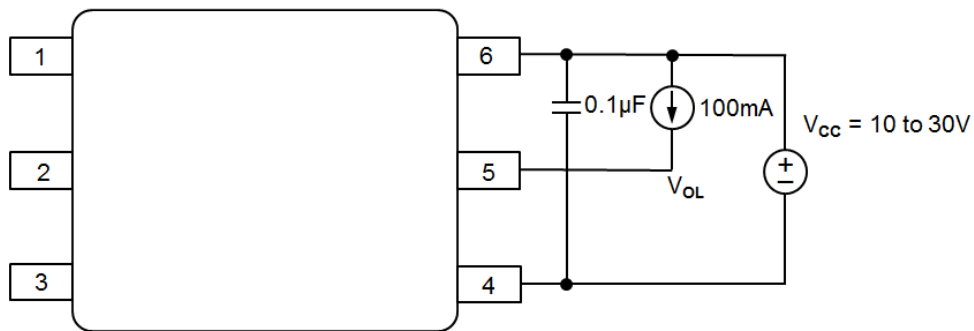

Fig 13 Propagation Delay vs Ambient Temperature



V_{OH} Test Circuit



V_{OL} Test Circuit



IS314P

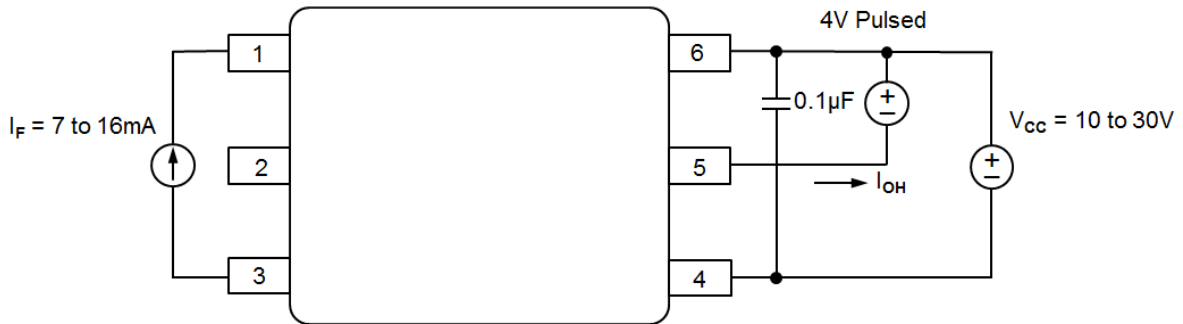

I_{OH} Test Circuit

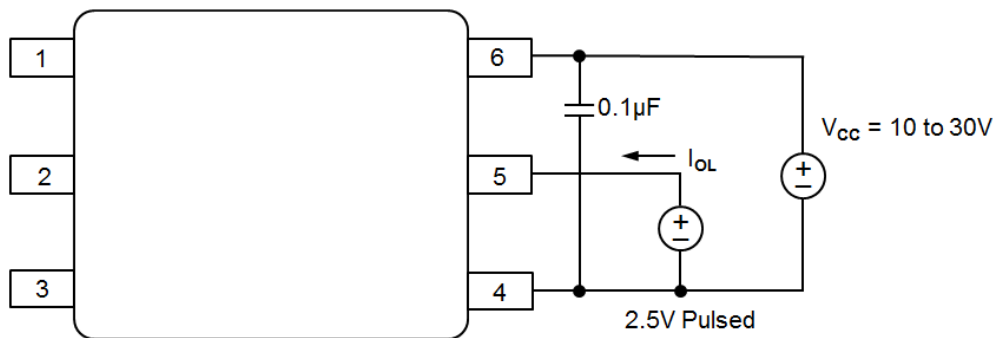

I_{OL} Test Circuit

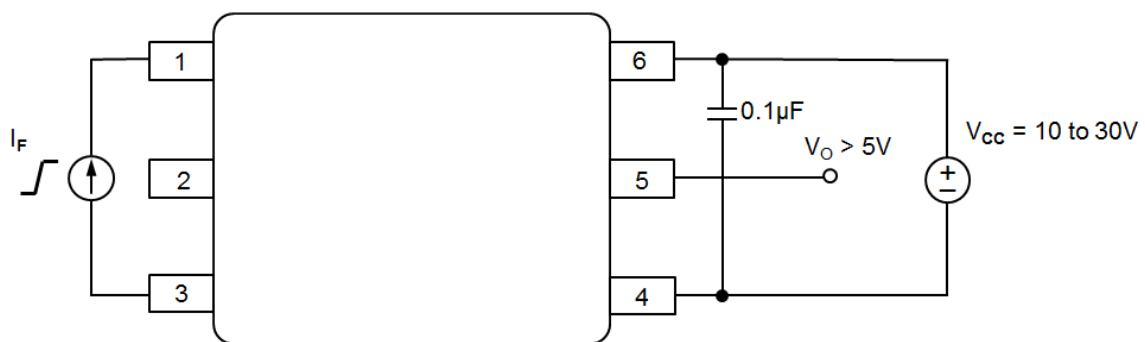

I_{FLH} Test Circuit



IS314P

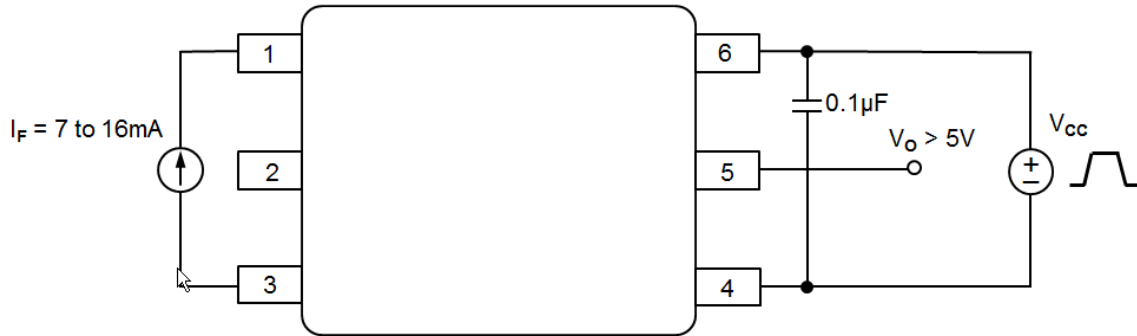

UVLO Test Circuit

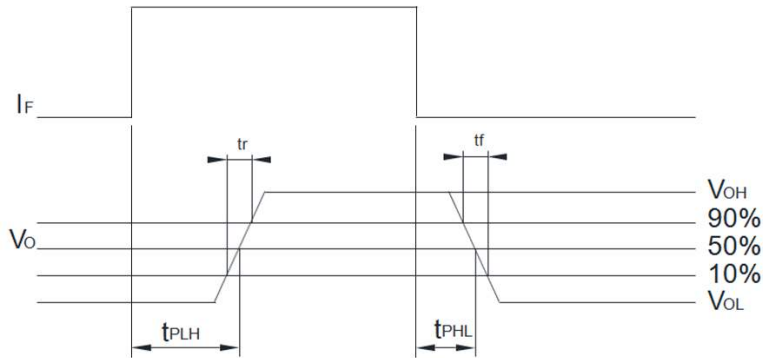
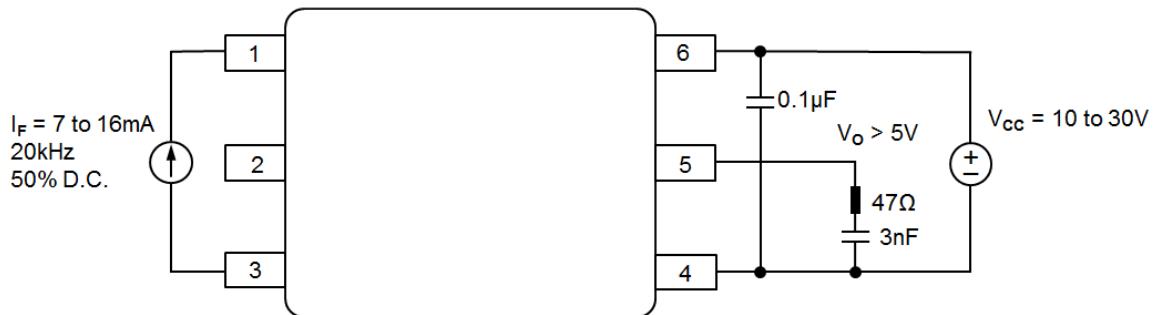

t_r , t_b , t_{PLH} and t_{PHL} Test Circuit and Waveform



IS314P

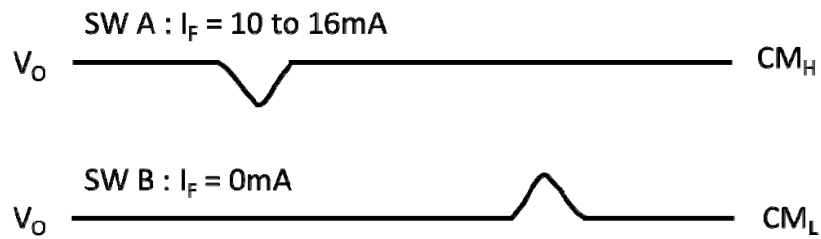
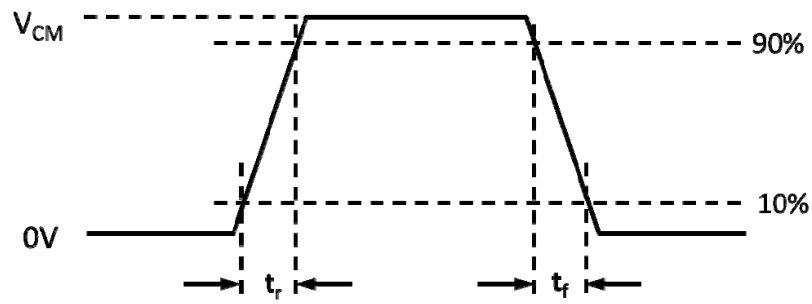
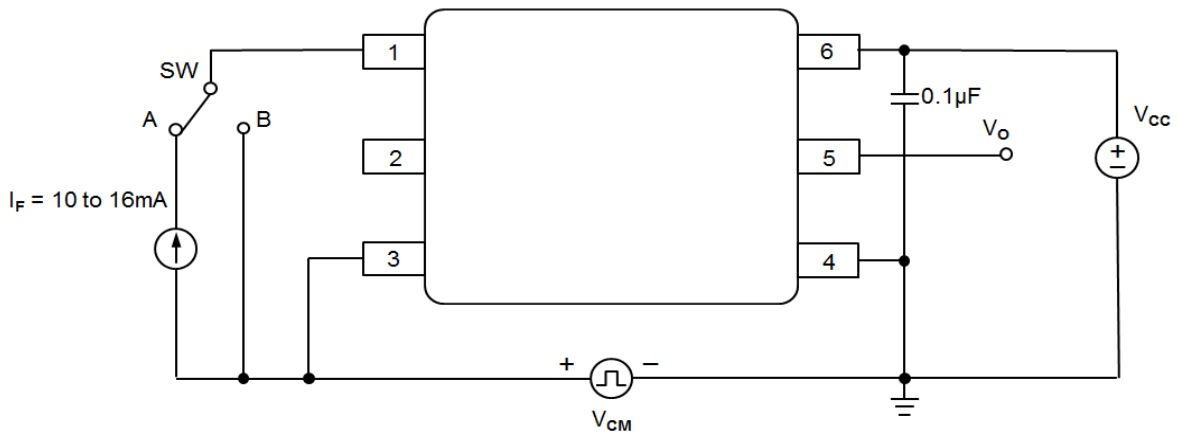

CMR Test Circuit and Waveform



IS314P

ORDER INFORMATION

IS314P			
After PN	PN	Description	Packing quantity
None	IS314P	Stretched SO6	1000 pcs per reel

DEVICE MARKING

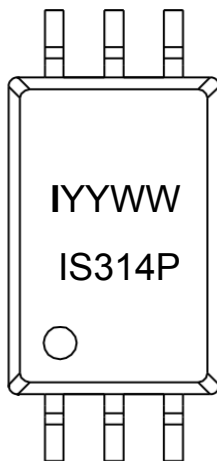

IS314P denotes Device Part Number
I denotes Isocom
YY denotes 2 digit Year code
WW denotes 2 digit Week code



IS314P

PACKAGE DIMENSIONS and Recommended PCB Pad Layout in mm (inch)

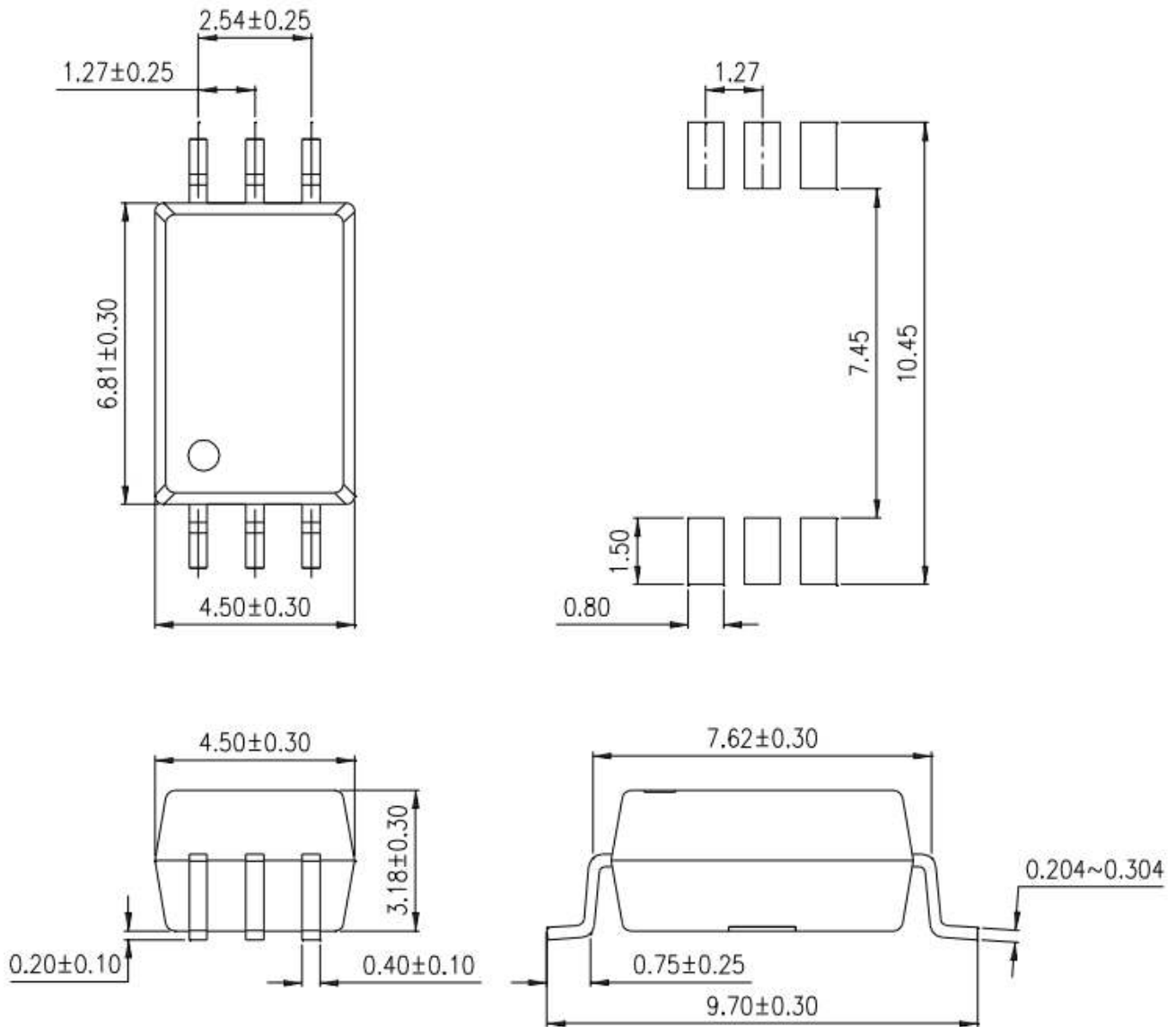



IS314P

TAPE AND REEL PACKAGING

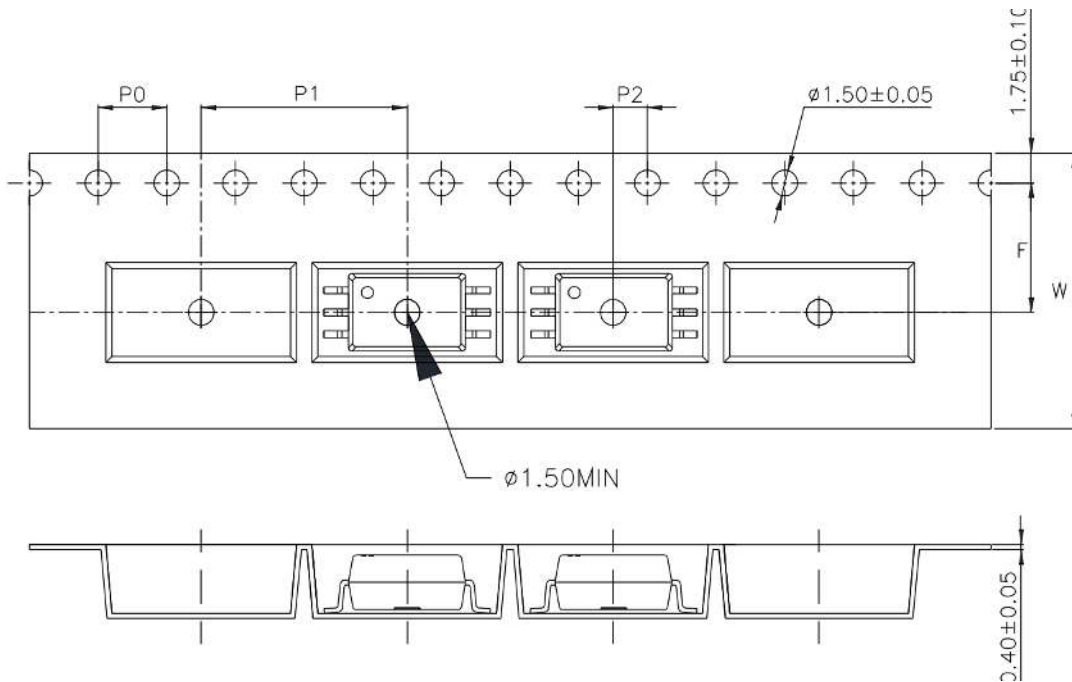

Description	Symbol	Dimension mm (inch)
Tape Width	W	16 ± 0.3 (0.63)
Pitch of Sprocket Holes	P_0	4 ± 0.1 (0.16)
Distance of Compartment to Sprocket Holes	F	7.5 ± 0.1 (0.3)
	P_2	2 ± 0.1 (0.079)
Distance of Compartment to Compartment	P_1	12 ± 0.1 (0.47)



IS314P

IR REFLOW SOLDERING TEMPERATURE PROFILE
(One Time Reflow Soldering is Recommended)

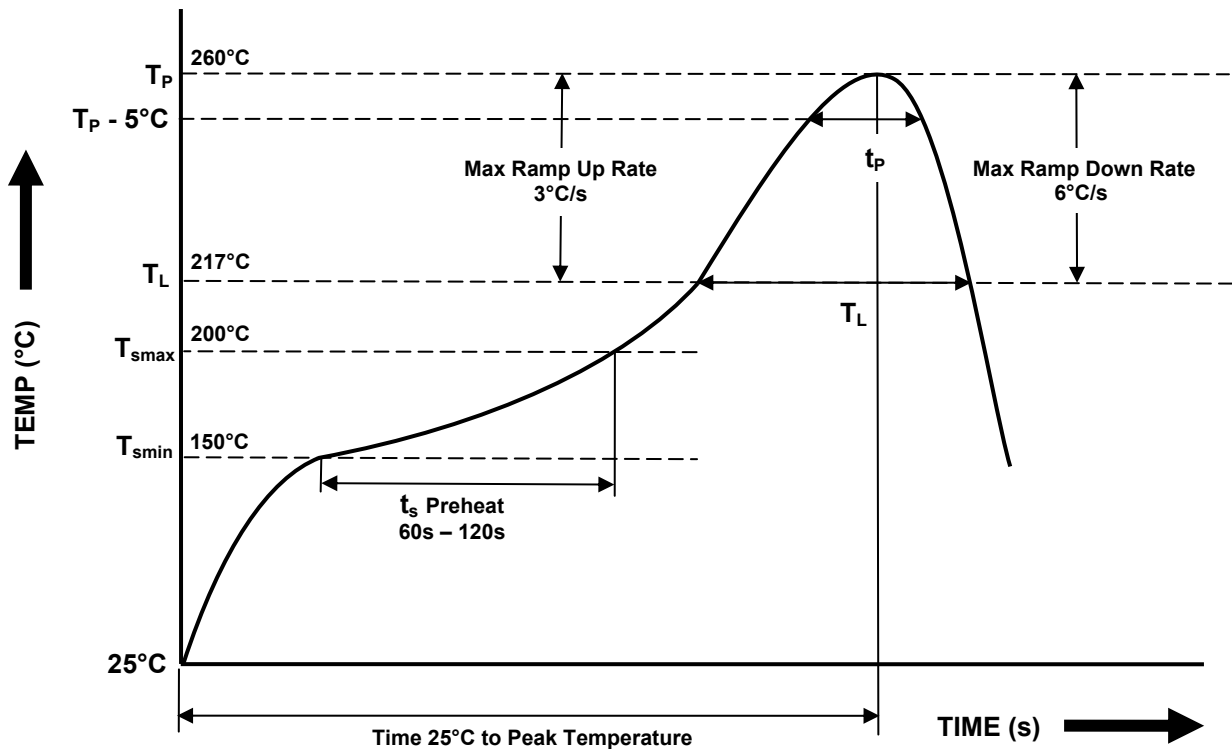

Profile Details	Conditions
Preheat - Min Temperature (T_{SMIN}) - Max Temperature (T_{SMAX}) - Time T_{SMIN} to T_{SMAX} (t_s)	150°C 200°C 60s - 120s
Soldering Zone - Peak Temperature (T_P) - Time at Peak Temperature - Liquidous Temperature (T_L) - Time within 5°C of Actual Peak Temperature ($T_P - 5^\circ C$) - Time maintained above T_L (t_L) - Ramp Up Rate (T_L to T_P) - Ramp Down Rate (T_P to T_L)	260°C 10s max 217°C 30s max 60s - 100s 3°C/s max 6°C/s max
Average Ramp Up Rate (T_{smax} to T_P)	3°C/s max
Time 25°C to Peak Temperature	8 minutes max



ISOCOM
—|>—|□—|<—||
COMPONENTS

IS314P

NOTES :

- Isocom is continually improving the quality, reliability, function or design and Isocom reserves the right to make changes without further notices.
- The products shown in this publication are designed for the general use in electronic applications such as office automation equipment, communications devices, audio/visual equipment, electrical application and instrumentation.
- For equipment/application where high reliability or safety is required, such as space applications, nuclear power control equipment, medical equipment, etc., please contact our sales representatives.
- When requiring a device for any "specific" application, please contact our sales for advice.
- The contents described herein are subject to change without prior notice.
- Do not immerse device body in solder paste.

