

Product data sheet

Specifications



pressure switch XMLB - 4 bar - adjustable scale 2 thresholds - 1 C/O

XMLB004A2S12EX

Main

Range of product	Telemecanique Pressure sensors XM
Pressure sensor type	Electromechanical pressure sensor
Product specific application	ATEX D
Pressure sensor name	XMLB
Electrical circuit type	Control circuit
Pressure switch type of operation	Regulation between 2 thresholds
Scale type	Adjustable differential
Pressure sensor size	4 bar
Local display	With
Fluid connection type	G 1/4 (female) conforming to ISO 228
Adjustable range of switching point on falling pressure	0.05...3.75 bar
Adjustable range of switching point on rising pressure	0.25...4 bar
Possible differential maximum at high setting	2.4 bar
Maximum permissible accidental pressure	9 bar
Destruction pressure	18 bar
Pressure actuator	Diaphragm
Controlled fluid	Hydraulic oil (0...70 °C) Air (0...70 °C) Water (0...70 °C)
Materials in contact with fluid	Zinc alloy Nitrile
Enclosure material	Zinc alloy

Complementary

Maximum permissible pressure - per cycle	5 bar
Cable entry number	1 tapped entry for M20 x 1.5 cable gland (included)
Terminal block type	4 terminals
Repeat accuracy	2 %

Auxiliary contacts operation	Snap action
Contacts material	Silver contacts
Mechanical durability	8000000 cycles
Setting	External
Terminals description ISO n°1	(13-14-11-12)OF
Height	158 mm
Depth	77.5 mm
Width	55 mm

Environment

Standards	EN/IEC 60079-0 EN/IEC 60079-31
Directives	2014/34/EU - ATEX directive
Product certifications	INERIS 04ATEX0058 IEC-Ex INE 17.0019
Marking	II2 D-Ex tb IIIC T85°C Db IP66
Protective treatment	TC
Ambient air temperature for operation	-20...60 °C
Operating position	Any position

Packing Units

Unit Type of Package 1	PCE
Number of Units in Package 1	1
Package 1 Height	14.5 cm
Package 1 Width	8 cm
Package 1 Length	6 cm
Package 1 Weight	1.021 kg

Offer Sustainability

Sustainable offer status	Green Premium product
REACH Regulation	REACH Declaration
EU RoHS Directive	Pro-active compliance (Product out of EU RoHS legal scope) EU RoHS Declaration
Mercury free	Yes
RoHS exemption information	Yes
Environmental Disclosure	Product Environmental Profile
California proposition 65	WARNING: This product can expose you to chemicals including: Diisononyl phthalate (DINP), which is known to the State of California to cause cancer, and Di-isodecyl phthalate (DIDP), which is known to the State of California to cause birth defects or other reproductive harm. For more information go to www.P65Warnings.ca.gov

Contractual warranty

Warranty	18 months
-----------------	-----------

Dimensions

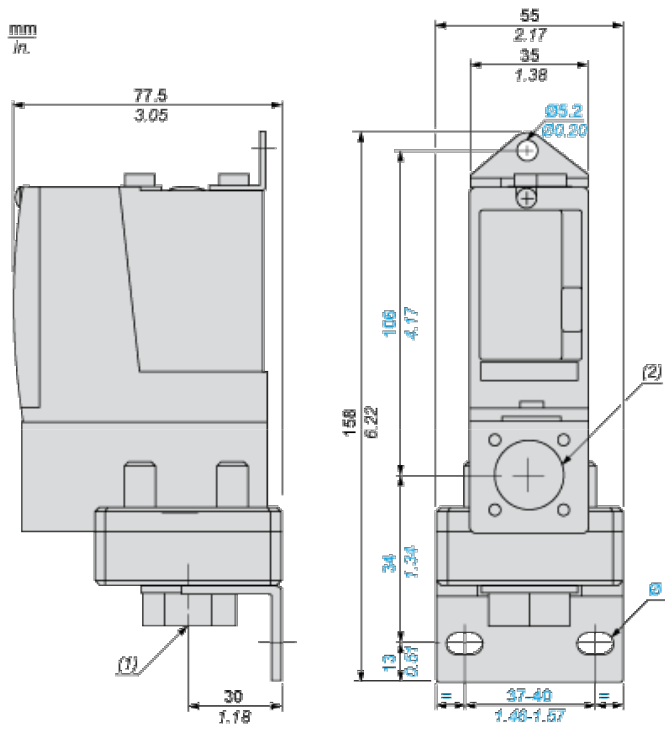

- (1) 1 fluid entry, tapped G1/4 (BSP female)
- (2) 1 electrical connections entry, tapped M20 x 1.5
- Ø : 2 elongated holes Ø 10.2 x 5.2

Wiring Diagram

Terminal Model

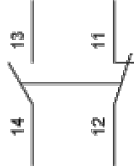

Operating Curves

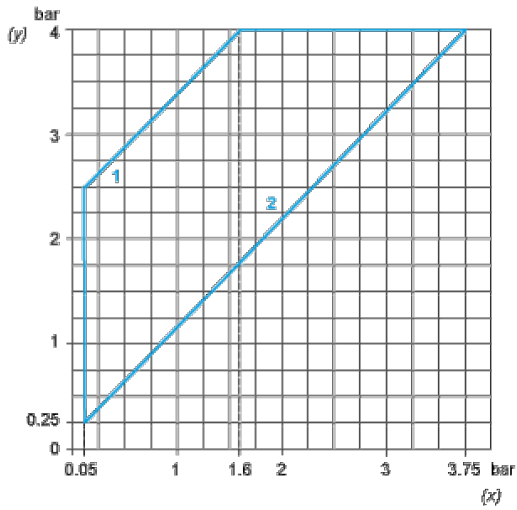

- (y) Rising pressure
- (x) Falling pressure
- 1 : Maximum differential
- 2 : Minimum differential

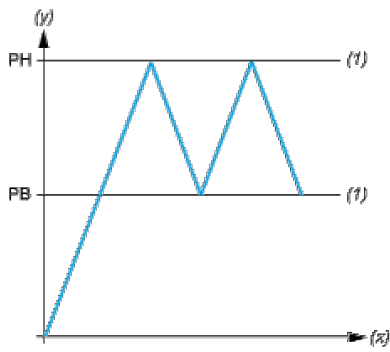

- (y) Pressure
- (x) Time
- (1) Adjustable value
- PH : High point
- PB : Below point

Recommended replacement(s)