

---

## (iSphynx II) 1394 Integrated PHY and Link-Layer Controller for SBP-2 Products and DPP Products

---

### FEATURES

- IEEE 1394a-2000 Compliant
  - Single 3.3-V Supply
  - Internal 1.8-V Circuit to Reduce Power Consumption
  - Integrated 400-Mbps Two-Port Physical Layer (PHY)
  - Internal Voltage Regulator
  - IEEE 1394 Related Functions:
    - Automated Read Response for ConfigROM Register Access
    - Automated Single Retry Protocol and Split Transaction Control
  - SBP-2 Related Functions:
    - Supports Four Initiators by Automated Transactions and More Can Be Supported Through Firmware.
    - Automated Management ORB Fetching
    - Automated Linked Command ORB Fetching
    - Automated PageTable Fetching
    - Automated Status Block Transmit
  - Ability to Support Direct Print Protocol (DPP) Mode
- Data Transfers:
    - Auto Address Increment of Direct/Indirect Addressing on Data Transfer (Packetizer)
    - Automated Header Insert/Strip for DMA Data Transfers
    - 8-/16-Bit Asynchronous and Synchronous DMA I/F With Handshake and Burst Mode
    - Supports ATAPI (Ultra-DMA) Mode and SCSI Mode
    - 8-/16-Bit Data/Address Multiplex Microcontroller and 8-/16-Bit Separated Data/Address Bus
    - Three FIFO Configurations That Support High Performance for the DMA and for Command Exchanges
      - Asynchronous Command FIFO: 1512 Bytes
      - Config ROM/LOG FIFO: 504 Bytes
      - DMA FIFO: 4728 Bytes

### DESCRIPTION

The TSB43AA82A is a high performance 1394 integrated PHY and link layer controller. It is compliant with the IEEE 1394-1995 and IEEE 1394a-2000 specifications and supports asynchronous transfers.

TSB43AA82A has a generic 16-/8-bit host bus interface. It supports parallel or multiplexed connections to the microcontroller (MCU) at rates up to 40 MHz.

The TSB43AA82A offers large data transfers with three mutually independent FIFOs: 1) the asynchronous command FIFO with 1512 Bytes, 2) the DMA FIFO with 4728 bytes and 3) the Config ROM/LOG FIFO with 504 bytes.

The features of the TSB43AA82A support the serial bus protocol 2 (SBP-2). It handles up to four initiators with the SBP-2 transaction/timer manager. This SBP-2 transaction engine supports fully automated operation request block (ORB) fetches and fully automated memory page table fetches for both read and write transactions. Automated responses to other node requests are provided; this includes responding to another node's read request to the Config ROM and issuing ack\_busy\_X for a single retry. Various control registers enable the user to program IEEE 1394 asynchronous transaction settings. The user can program the number of retries and the split transaction time-out value by setting the time limit register in the CFR.



Please be aware that an important notice concerning availability, standard warranty, and use in critical applications of Texas Instruments semiconductor products and disclaimers thereto appears at the end of this data sheet.

The TSB43AA82A also supports the direct print protocol (DPP). The asynchronous receive FIFO (ARF) in the TSB43AA82A is large enough to satisfy the connection register area, the DRF receiving FIFO can be used as the segment data unit (SDU) register to fulfill the large data transfer.

This document is not intended to serve as a tutorial on IEEE 1394; users are referred to IEEE Std 1394-1995 and IEEE 1394a-2000 .<sup>(1)</sup>

**NOTE:**

This product is for high-volume CE applications only. For a complete datasheet or more information contact support@ti.com.

- (1) IEEE Std 1394-1995, *IEEE Standard for a High Performance Serial Bus* IEEE Std 1394a-2000, *IEEE Standard for a High Performance Serial Bus – Amendment 1*

**PACKAGING INFORMATION**

Orderable Device	Status (1)	Package Type	Package Drawing	Pins	Package Qty	Eco Plan (2)	Lead finish/ Ball material (6)	MSL Peak Temp (3)	Op Temp (°C)	Device Marking (4/5)	Samples
TSB43AA82APGE	ACTIVE	LQFP	PGE	144	60	RoHS & Green	NIPDAU	Level-2-260C-1 YEAR	0 to 70	TSB43AA82A	Samples

(1) The marketing status values are defined as follows:

**ACTIVE:** Product device recommended for new designs.

**LIFEBUY:** TI has announced that the device will be discontinued, and a lifetime-buy period is in effect.

**NRND:** Not recommended for new designs. Device is in production to support existing customers, but TI does not recommend using this part in a new design.

**PREVIEW:** Device has been announced but is not in production. Samples may or may not be available.

**OBSELETE:** TI has discontinued the production of the device.

(2) **RoHS:** TI defines "RoHS" to mean semiconductor products that are compliant with the current EU RoHS requirements for all 10 RoHS substances, including the requirement that RoHS substance do not exceed 0.1% by weight in homogeneous materials. Where designed to be soldered at high temperatures, "RoHS" products are suitable for use in specified lead-free processes. TI may reference these types of products as "Pb-Free".

**RoHS Exempt:** TI defines "RoHS Exempt" to mean products that contain lead but are compliant with EU RoHS pursuant to a specific EU RoHS exemption.

**Green:** TI defines "Green" to mean the content of Chlorine (Cl) and Bromine (Br) based flame retardants meet JS709B low halogen requirements of <=1000ppm threshold. Antimony trioxide based flame retardants must also meet the <=1000ppm threshold requirement.

(3) MSL, Peak Temp. - The Moisture Sensitivity Level rating according to the JEDEC industry standard classifications, and peak solder temperature.

(4) There may be additional marking, which relates to the logo, the lot trace code information, or the environmental category on the device.

(5) Multiple Device Markings will be inside parentheses. Only one Device Marking contained in parentheses and separated by a "~" will appear on a device. If a line is indented then it is a continuation of the previous line and the two combined represent the entire Device Marking for that device.

(6) Lead finish/Ball material - Orderable Devices may have multiple material finish options. Finish options are separated by a vertical ruled line. Lead finish/Ball material values may wrap to two lines if the finish value exceeds the maximum column width.

**Important Information and Disclaimer:**The information provided on this page represents TI's knowledge and belief as of the date that it is provided. TI bases its knowledge and belief on information provided by third parties, and makes no representation or warranty as to the accuracy of such information. Efforts are underway to better integrate information from third parties. TI has taken and continues to take reasonable steps to provide representative and accurate information but may not have conducted destructive testing or chemical analysis on incoming materials and chemicals. TI and TI suppliers consider certain information to be proprietary, and thus CAS numbers and other limited information may not be available for release.

In no event shall TI's liability arising out of such information exceed the total purchase price of the TI part(s) at issue in this document sold by TI to Customer on an annual basis.

**OTHER QUALIFIED VERSIONS OF TSB43AA82A :**

- Enhanced Product : [TSB43AA82A-EP](#)

NOTE: Qualified Version Definitions:

- Enhanced Product - Supports Defense, Aerospace and Medical Applications

**TRAY**

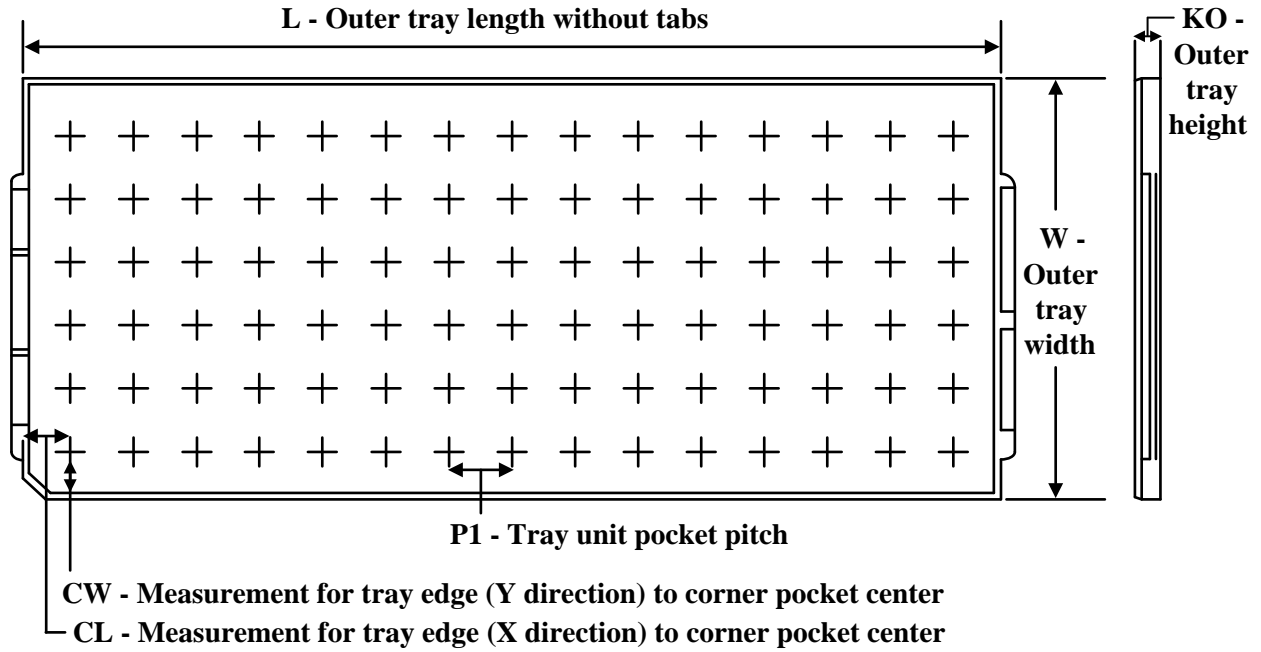

Chamfer on Tray corner indicates Pin 1 orientation of packed units.

\*All dimensions are nominal

Device	Package Name	Package Type	Pins	SPQ	Unit array matrix	Max temperature (°C)	L (mm)	W (mm)	K0 (µm)	P1 (mm)	CL (mm)	CW (mm)
TSB43AA82APGE	PGE	LQFP	144	60	5X12	150	315	135.9	7620	25.4	17.8	17.55

PGE (S-PQFP-G144)

PLASTIC QUAD FLATPACK

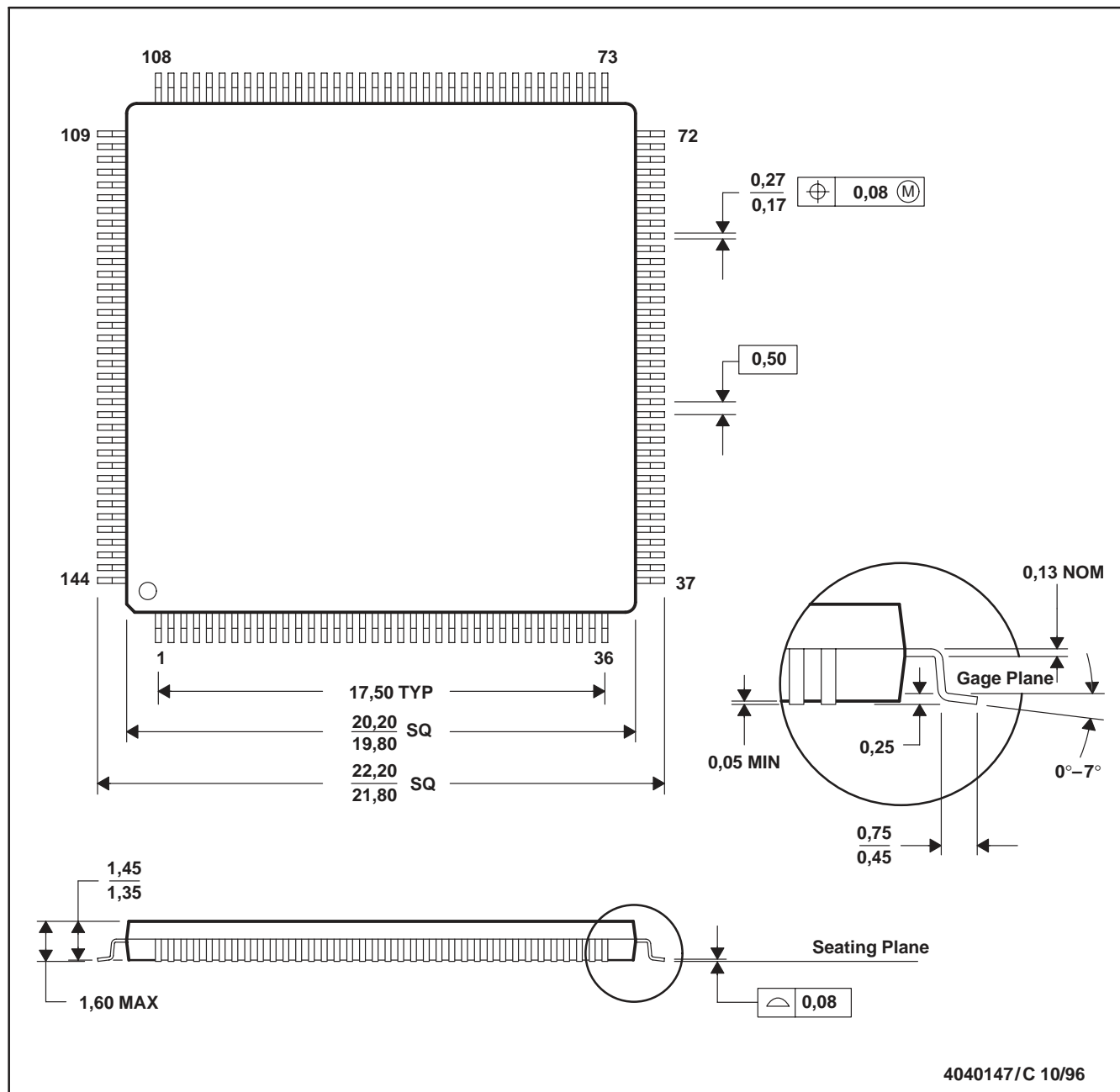

- NOTES: A. All linear dimensions are in millimeters.  
 B. This drawing is subject to change without notice.  
 C. Falls within JEDEC MS-026

## IMPORTANT NOTICE AND DISCLAIMER

TI PROVIDES TECHNICAL AND RELIABILITY DATA (INCLUDING DATA SHEETS), DESIGN RESOURCES (INCLUDING REFERENCE DESIGNS), APPLICATION OR OTHER DESIGN ADVICE, WEB TOOLS, SAFETY INFORMATION, AND OTHER RESOURCES "AS IS" AND WITH ALL FAULTS, AND DISCLAIMS ALL WARRANTIES, EXPRESS AND IMPLIED, INCLUDING WITHOUT LIMITATION ANY IMPLIED WARRANTIES OF MERCHANTABILITY, FITNESS FOR A PARTICULAR PURPOSE OR NON-INFRINGEMENT OF THIRD PARTY INTELLECTUAL PROPERTY RIGHTS.

These resources are intended for skilled developers designing with TI products. You are solely responsible for (1) selecting the appropriate TI products for your application, (2) designing, validating and testing your application, and (3) ensuring your application meets applicable standards, and any other safety, security, regulatory or other requirements.

These resources are subject to change without notice. TI grants you permission to use these resources only for development of an application that uses the TI products described in the resource. Other reproduction and display of these resources is prohibited. No license is granted to any other TI intellectual property right or to any third party intellectual property right. TI disclaims responsibility for, and you will fully indemnify TI and its representatives against, any claims, damages, costs, losses, and liabilities arising out of your use of these resources.

TI's products are provided subject to [TI's Terms of Sale](#) or other applicable terms available either on [ti.com](http://ti.com) or provided in conjunction with such TI products. TI's provision of these resources does not expand or otherwise alter TI's applicable warranties or warranty disclaimers for TI products.

TI objects to and rejects any additional or different terms you may have proposed.

Mailing Address: Texas Instruments, Post Office Box 655303, Dallas, Texas 75265  
Copyright © 2022, Texas Instruments Incorporated