

Linear Constant Current Regulated LED Driver

DESCRIPTION

The TSCR420 & TSCR421 are Low-Side Constant Current Regulator (CCR) for linear LED driving. The device regulates with a preset 10mA nominal that can be adjusted with an external resistor up to 300mA. It is designed for driving LEDs in strings and will reduce current at increasing temperatures to self-protect. Operating as a series linear CCR for LED string current control, it can be used in multiple applications, as long as the maximum supply voltage to the device is <math><40V</math>.

With the low-side control, the TSCR421 has an Enable (EN) pin which can be pulse-width modulated (PWM) up to 10kHz by a microcontroller for LED dimming.

The output current at higher temperatures is the result of the negative temperature coefficient of 0.07%/°C of the LED driver.

FEATURES

- AEC-Q100 qualified with the following results:
 - Device temperature grade 1: -40°C to 125°C
 - Device HBM ESD classification level H2
 - Device CDM ESD classification level C6
- LED drive current preset to 10mA
- Continuous output current up to 300mA with an external resistor
- Very low enable current
- Easy paralleling of drivers to increase current
- Supply voltage up to 40V
- Digital PWM input up to 10kHz (TSCR421)
- Good temperature coefficient vs. output current
- Compliant to RoHS Directive 2011/65/EU and in accordance to WEEE 2002/96/EC.
- Halogen-Free according to IEC 61249-2-21

APPLICATION

- Automotive Lighting
- Architectural LED lighting, emergency lighting
- Signage, Advertising, Decorative Lighting
- Retail Lighting in Fridges and Vending Machines



SOT-26



Pin Definition:

- | | |
|--------|---------------------|
| 1. EN | 6. R _{EXT} |
| 2. OUT | 5. OUT |
| 3. OUT | 4. GND |

Notes: MSL 1 (Moisture Sensitivity Level) per J-STD-020

TYPICAL APPLICATION CIRCUIT

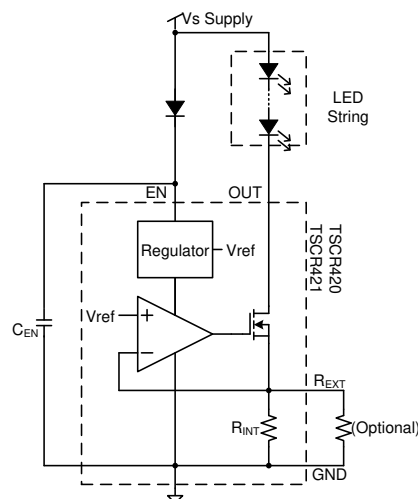

ABSOLUTE MAXIMUM RATINGS ($T_A = 25^\circ\text{C}$ unless otherwise specified) ^(Note 1)				
PARAMETER		SYMBOL	LIMIT	UNIT
Enable voltage	TSCR420	V_{EN}	40	V
	TSCR421		4.5	
Output current		I_{OUT}	300	mA
Output voltage		V_{OUT}	40	V
Reverse voltage between all terminals		V_R	0.5	V
Total power dissipation @ $T_A=25^\circ\text{C}$ ^(Note)		P_{TOT}	1	W
Junction temperature range		T_J	-55 to +150	$^\circ\text{C}$
Operating ambient temperature range		T_A	-40 to +125	$^\circ\text{C}$
Storage temperature range		T_{STG}	-65 to +150	$^\circ\text{C}$
ESD Rating (Human Body Model)		HBM	± 2	kV
ESD Rating (Charge Device Model)		CDM	± 1	kV

Note:

Stresses above the max. values listed here may cause permanent damage to the device. Exposure to absolute maximum rating conditions for extended periods may affect device reliability. Maximum ratings are absolute ratings; exceeding only one of these values may cause irreversible damage to the integrated circuit.

THERMAL PERFORMANCE				
PARAMETER		SYMBOL	TYP	UNIT
Thermal Resistance - Junction to Ambient		$R_{\theta JA}$	225	$^\circ\text{C/W}$
Thermal Resistance - Junction to Case		$R_{\theta JC}$	125	$^\circ\text{C/W}$
Thermal Resistance - Junction to Lead		$R_{\theta JL}$	145	$^\circ\text{C/W}$

ELECTRICAL SPECIFICATIONS ($T_A = 25^\circ\text{C}$ unless otherwise noted)							
PARAMETER		CONDITIONS	SYMBOL	MIN	TYP	MAX	UNIT
Break Down Voltage			V_{BR}	40	--	--	V
Enable Current	TSCR420	$V_{EN}=24\text{V}$	I_{EN}	--	450	--	μA
	TSCR421	$V_{EN}=3.3\text{V}$		--	36	--	μA
Internal Resistor		$I_{RINT}=10\text{mA}$	R_{INT}	85	95	105	Ω
Output Current	TSCR420	$V_{OUT}=1.4\text{V}, V_{EN}=24\text{V}$	I_{OUT}	9	10	11	mA
	TSCR421	$V_{OUT}=1.4\text{V}, V_{EN}=3.3\text{V}$		9	10	11	
Output Current at $R_{EXT}=5.1\Omega$	TSCR420	$V_{OUT}>2.0\text{V}, V_{EN}=24\text{V}$		--	150	--	
	TSCR421	$V_{OUT}>2.0\text{V}, V_{EN}=3.3\text{V}$		--	150	--	
Voltage Drop (V_{REXT})		$I_{OUT}=10\text{mA}$	V_{DROP}	0.85	0.95	1.05	V
Minimum Output Voltage		$I_{OUT}>18\text{mA}$	$V_{OUT(MIN)}$	--	1.4	--	V
Output Current vs. Temperature	TSCR420	$V_{OUT}>2.0\text{V}, V_{EN}=24\text{V}$	$\Delta I_{OUT}/I_{OUT}$	--	-0.07	--	$\%/^\circ\text{C}$
	TSCR421	$V_{OUT}>2.0\text{V}, V_{EN}=3.3\text{V}$		--	-0.07	--	
Output Current vs. Supply Voltage	TSCR420	$V_{OUT}>2.0\text{V}, V_{EN}=24\text{V}$	$\Delta I_{OUT}/I_{OUT}$	--	0.33	--	$\%/V$
	TSCR421	$V_{OUT}>2.0\text{V}, V_{EN}=3.3\text{V}$		--	0.33	--	

ORDERING INFORMATION

ORDERING CODE	PACKAGE	PACKING
TSCR420CX6H RFG	SOT-26	3,000pcs / 7"Reel
TSCR421CX6H RFG	SOT-26	3,000pcs / 7"Reel

FUNCTION BLOCK

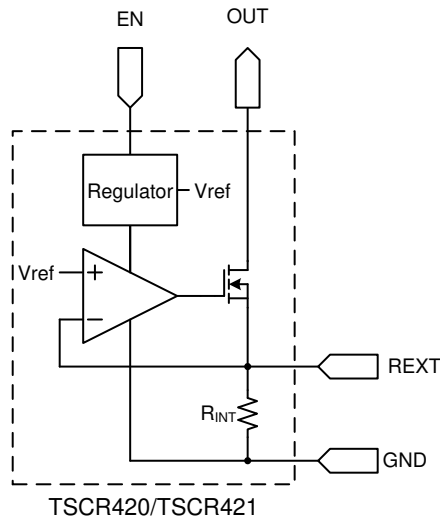

PIN DESCRIPTION

PIN NO.	NAME	FUNCTION
1	EN	Enable for biasing transistor
2	OUT	Regulated output current
3	OUT	Regulated output current
4	GND	Power ground
5	OUT	Regulated output current
6	R _{EXT}	External resistor for adjusting output current

TSCR420CX6 CHARACTERISTICS CURVES

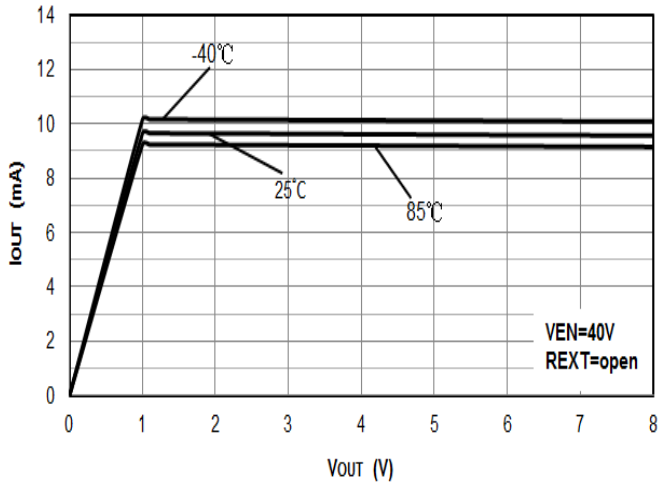

Figure 1. V_{OUT} vs. I_{OUT} ($R_{EXT}=open$)

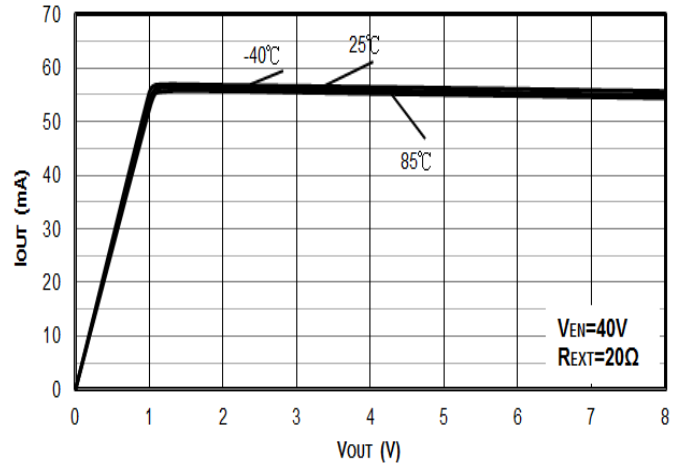

Figure 2. V_{OUT} vs. I_{OUT} ($R_{EXT}=20\Omega$)

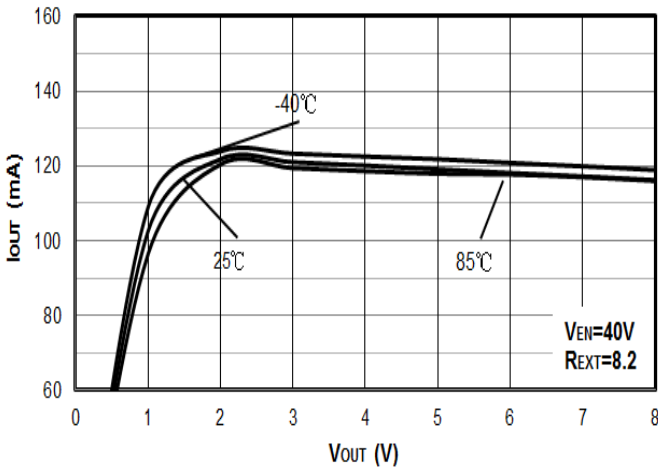

Figure 3. V_{OUT} vs. I_{OUT} ($R_{EXT}=8.2\Omega$)

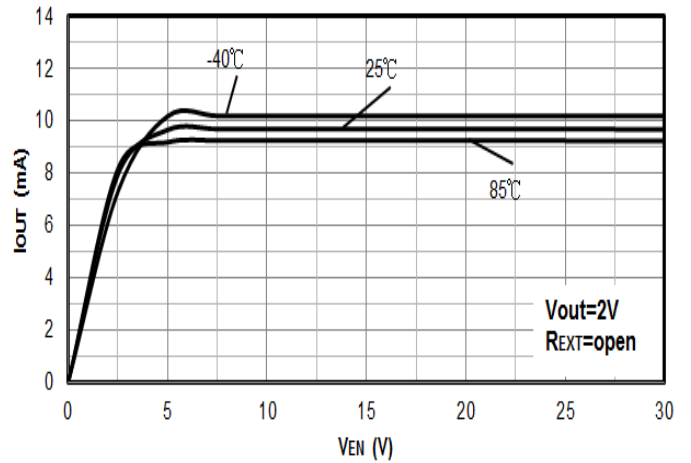

Figure 4. V_{EN} vs. I_{OUT} ($R_{EXT}=open$)

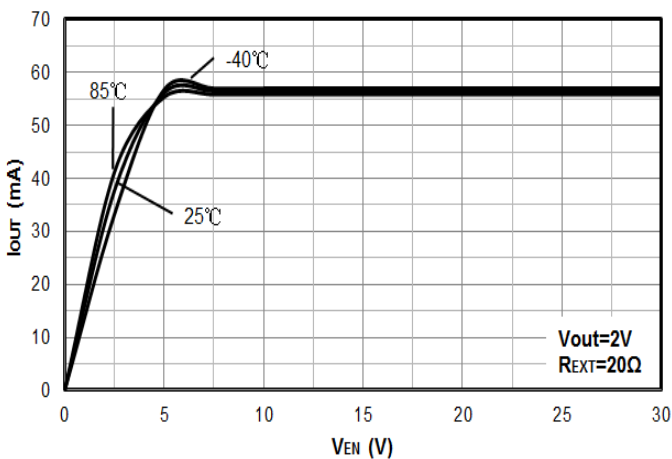

Figure 5. V_{EN} vs. I_{OUT} ($R_{EXT}=20\Omega$)

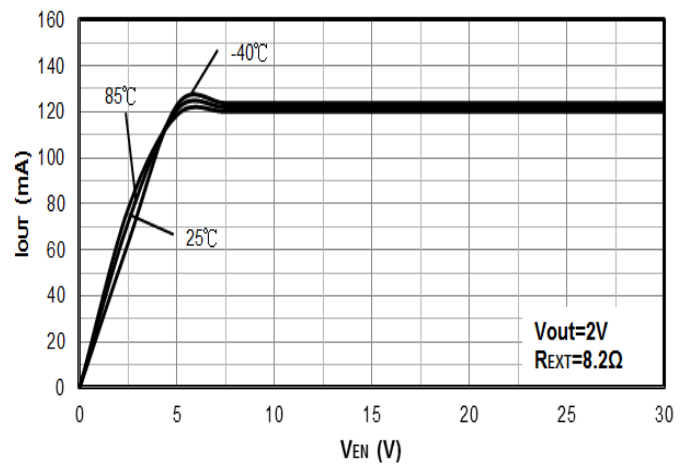

Figure 6. V_{EN} vs. I_{OUT} ($R_{EXT}=8.2\Omega$)

TSCR420CX6 CHARACTERISTICS CURVES

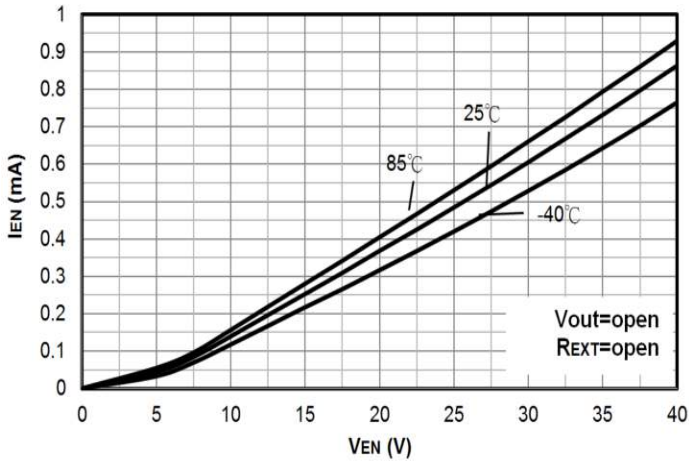

Figure 7. V_{EN} vs. I_{EN} ($R_{EXT}=open$)

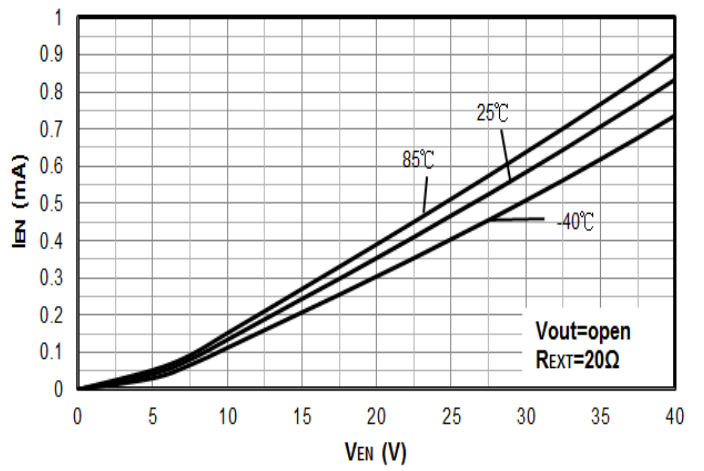

Figure 8. V_{EN} vs. I_{EN} ($R_{EXT}=20\Omega$)

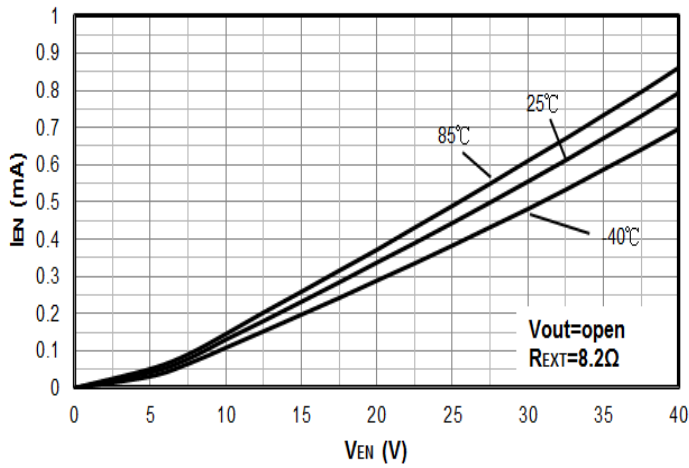

Figure 9. V_{EN} vs. I_{EN} ($R_{EXT}=8.2\Omega$)

TSCR421CX6 CHARACTERISTICS CURVES

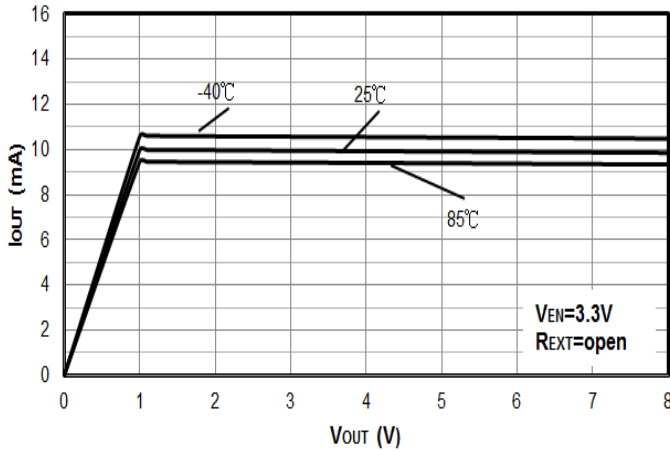

Figure 10. V_{OUT} vs. I_{OUT} ($R_{EXT}=open$)

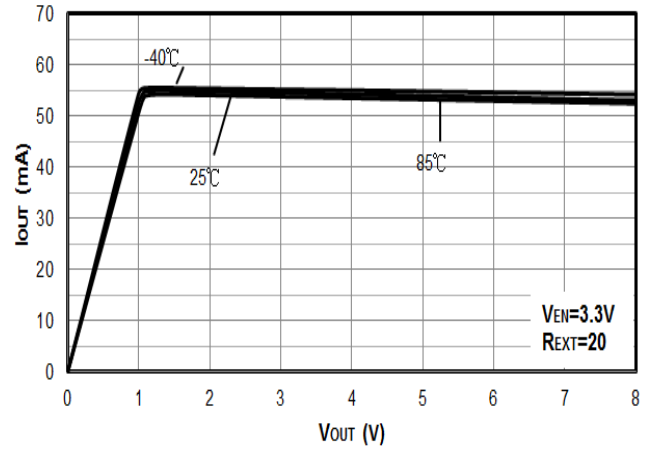

Figure 11. V_{OUT} vs. I_{OUT} ($R_{EXT}=20\Omega$)

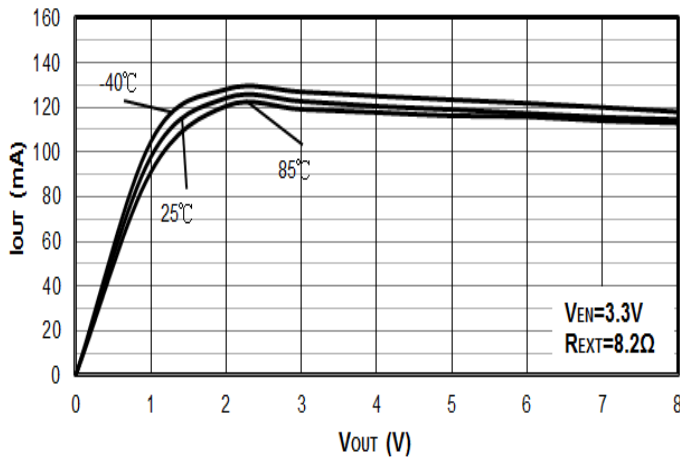

Figure 12. V_{OUT} vs. I_{OUT} ($R_{EXT}=8.2\Omega$)

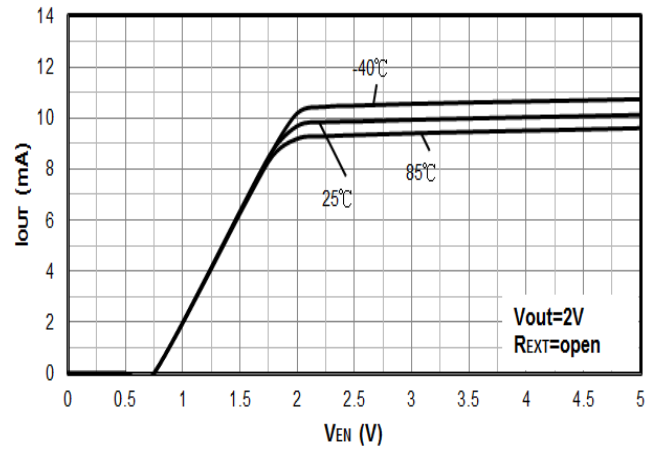

Figure 13. V_{EN} vs. I_{OUT} ($R_{EXT}=open$)

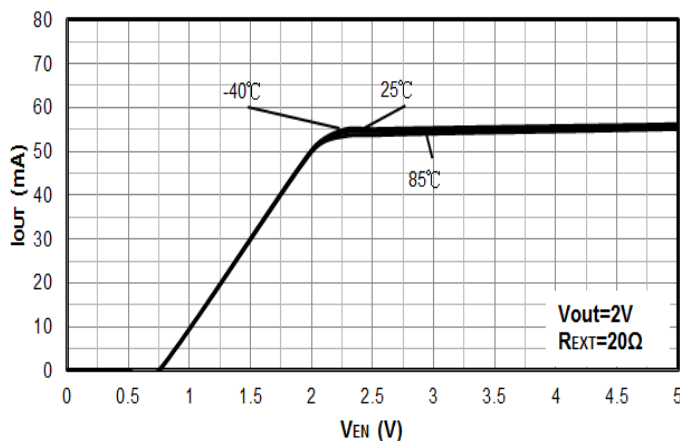

Figure 14. V_{EN} vs. I_{OUT} ($R_{EXT}=20\Omega$)

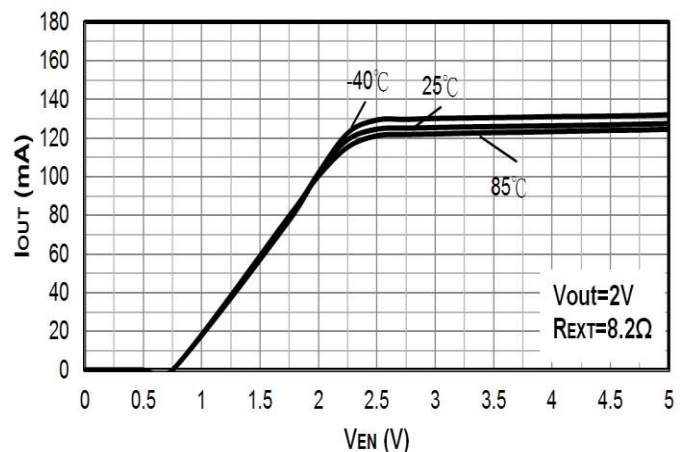

Figure 15. V_{EN} vs. I_{OUT} ($R_{EXT}=8.2\Omega$)

TSCR421CX6 CHARACTERISTICS CURVES

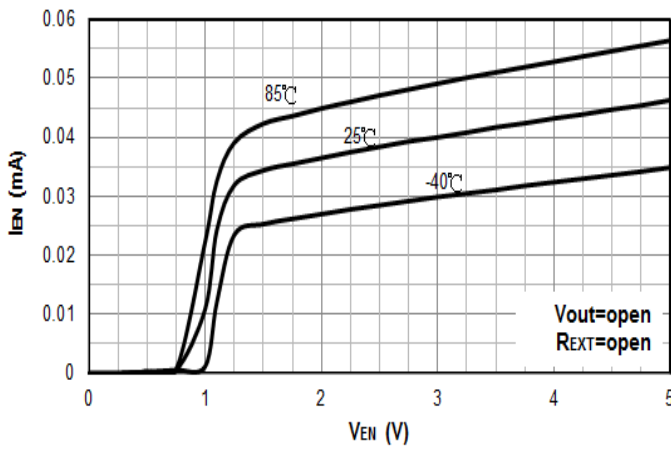

Figure 16. V_{EN} vs. I_{EN} ($R_{EXT}=open$)

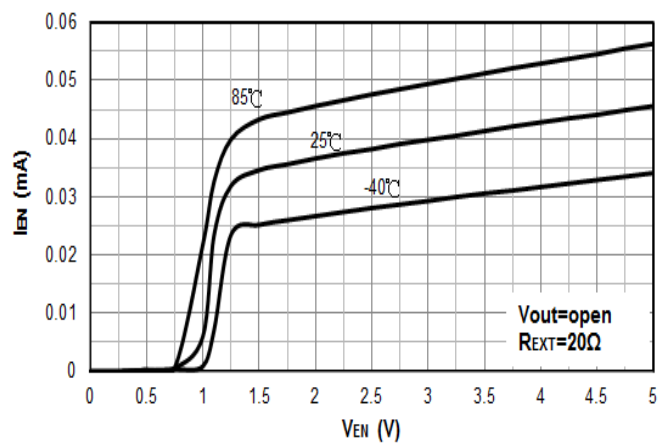

Figure 17. V_{EN} vs. I_{EN} ($R_{EXT}=20\Omega$)

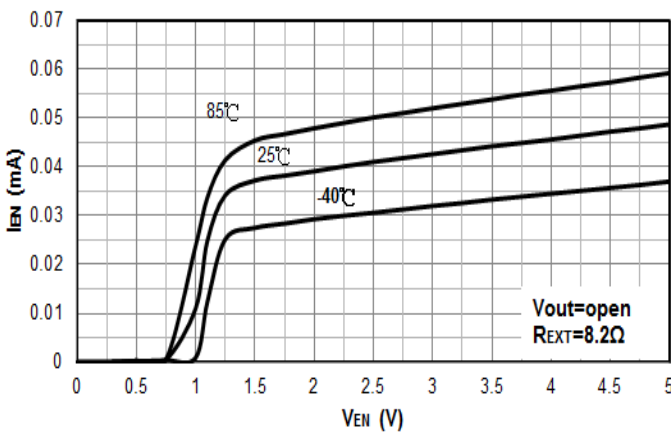

Figure 18. V_{EN} vs. I_{EN} ($R_{EXT}=8.2\Omega$)

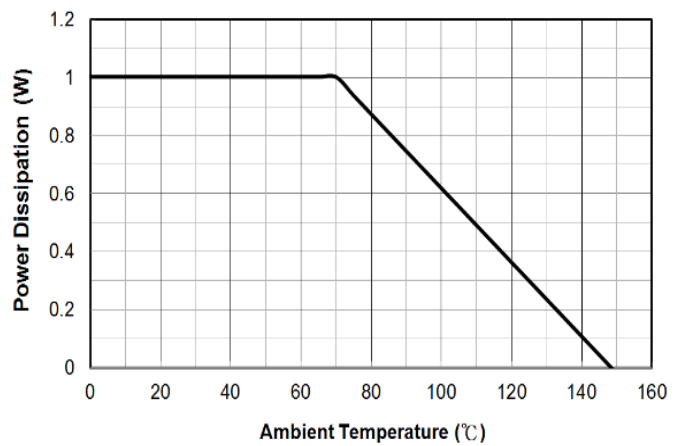

Figure 19. P_D vs. Ambient Temperature

APPLICATION INFORMATION

The TSCR420 & TSCR421 are designed for driving low current LEDs with typical LED currents of 10mA to 300mA. They provide a cost-effective way for driving low current LEDs compared with more complex switching regulator solutions. Furthermore, they reduce the PCB board area of the solution as there is no need for external components like inductors, capacitors and switching diodes

Figure 20 shows a typical application circuit diagram for driving an LED or string of LEDs. The device comes with an internal resistor (R_{INT}) of typically 95Ω, which in the absence of an external resistor, sets an LED current of 10mA (typical) from a $V_{EN} = 3.3V$ and $V_{OUT} = 1.4V$ for TSCR421; or $V_{EN} = 24V$ and $V_{OUT} = 1.4V$ for TSCR420. LED current can be increased to a desired value by choosing an appropriate external resistor, R_{EXT} .

The R_{EXT} vs I_{OUT} graphs should be used to select the appropriate resistor. Choosing a low tolerance R_{EXT} will improve the overall accuracy of the current sense formed by the parallel connection of R_{INT} and R_{EXT} .

$$R_{EXT} = V_{DROP} / (I_{OUT} - (V_{DROP}/R_{INT}))$$

Two or more TSCR420 & TSCR421 can be connected in parallel to construct higher current LED strings as shown in Figure 21. Consideration of the expected linear mode power dissipation must be factored into the design, with respect to the TSCR420 & TSCR421's thermal resistance. The maximum voltage across the device can be calculated by taking the maximum supply voltage and subtracting the voltage across the LED string.

$$V_{OUT} = V_S - V_{LED}$$

$$P_D = (V_{OUT} - V_{REXT}) \times I_{LED} + (V_{EN} \times I_{EN})$$

As the output current of TSCR420 & TSCR421 increases, it is necessary to provide appropriate thermal relief to the device. The power dissipation supported by the device is dependent upon the PCB board material, the copper area and the ambient temperature. The maximum dissipation the device can handle is given by:

$$P_D = (T_{J(MAX)} - T_A) / R_{\theta JA}$$

Refer to the thermal characteristic graphs on Page 4 for selecting the appropriate PCB copper area.

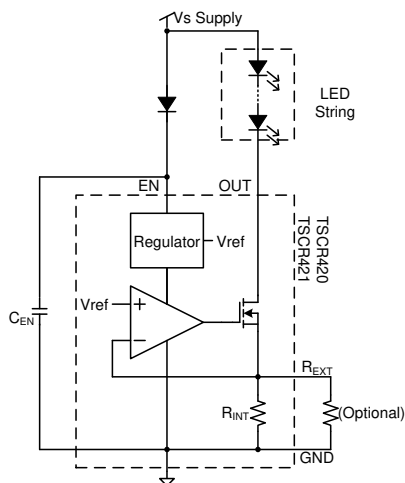

Figure 20: Typical Application Circuit for Linear Mode Current Sink LED Driver

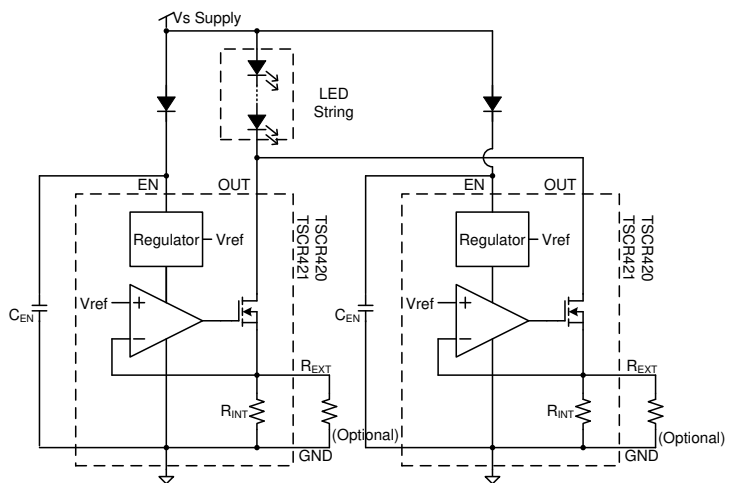

Figure 21: Application Circuit for Increasing LED Current

APPLICATION INFORMATION (CONTINUE)

PWM dimming can be achieved by driving the EN pin. Dimming is achieved by turning the LEDs ON and OFF for a portion of a single cycle. The PWM signal can be provided by a micro-controller or analog circuitry; typical circuit is shown in Figure 22.

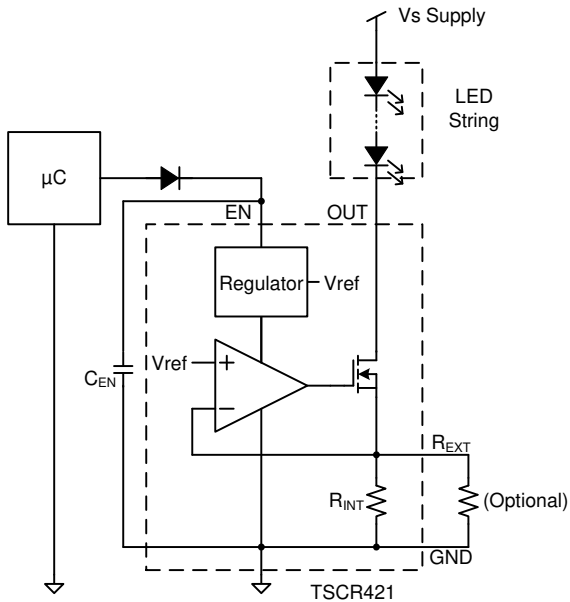

Figure 22: Application Circuit for LED Driver with PWM Dimming Functionality

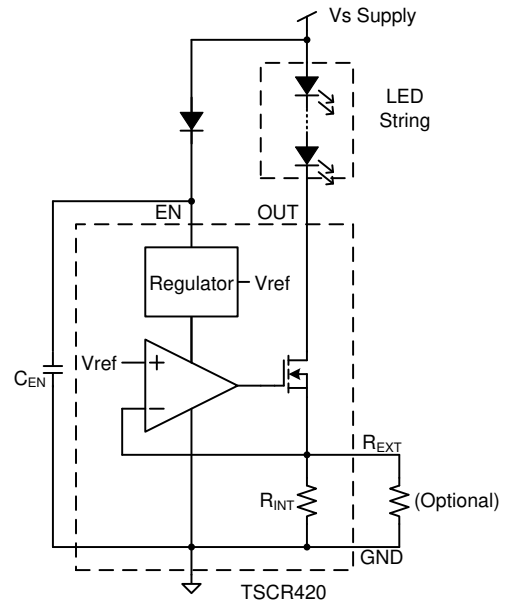
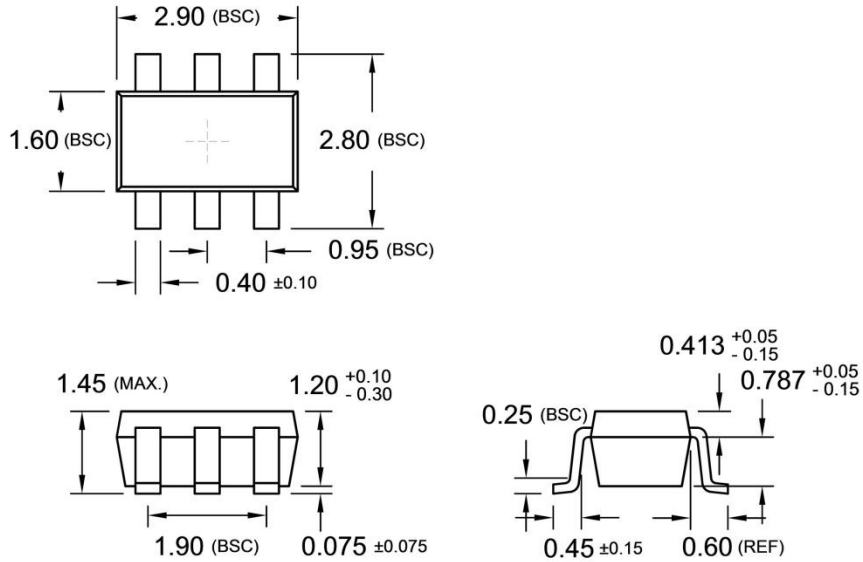

Figure 23: Application Circuit for LED Driver with High voltage EN Pin

PACKAGE OUTLINE DIMENSIONS (Unit: Millimeters)

SOT-26



SUGGESTED PAD LAYOUT (Unit: Millimeters)

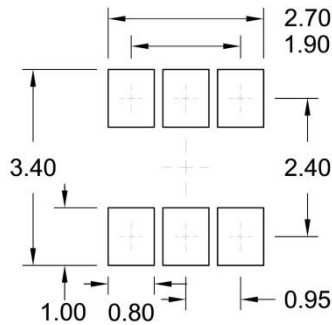

MARKING DIAGRAM

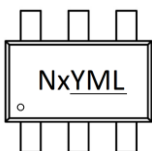

- Nx** = Device Code
 - N1 = TSCR420CX6
 - N2 = TSCR421CX6
- Y** = Year Code
- M** = Month Code for Halogen Free Product
 - O** =Jan **P** =Feb **Q** =Mar **R** =Apr
 - S** =May **T** =Jun **U** =Jul **V** =Aug
 - W** =Sep **X** =Oct **Y** =Nov **Z** =Dec
- L** = Lot Code (1~9, A~Z)

Notice

Specifications of the products displayed herein are subject to change without notice. TSC or anyone on its behalf, assumes no responsibility or liability for any errors or inaccuracies.

Information contained herein is intended to provide a product description only. No license, express or implied, to any intellectual property rights is granted by this document. Except as provided in TSC's terms and conditions of sale for such products, TSC assumes no liability whatsoever, and disclaims any express or implied warranty, relating to sale and/or use of TSC products including liability or warranties relating to fitness for a particular purpose, merchantability, or infringement of any patent, copyright, or other intellectual property right.

The products shown herein are not designed for use in medical, life-saving, or life-sustaining applications. Customers using or selling these products for use in such applications do so at their own risk and agree to fully indemnify TSC for any damages resulting from such improper use or sale.