

# GSA100AA60

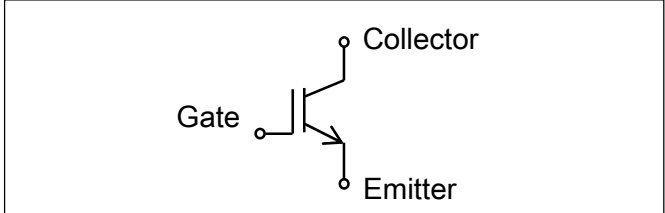

Same package as the product in this photo.

$V_{CES} = 600V$   
 $I_C = 100A$



■ IGBT

**Advantages**

- Low  $V_{ce(sat)}$  1.21V Typ 125°C
- Compatible package with SOT-227
- Can be small equipment thanks to small package
- Fully isolated package  $V_{iso}=2500V$
- EU RoHS compliant
- UL approved File No.E76102

**Applications**

- AC/DC TIG Welder, AC Switch for UPS, Pulse Reverse Rectifier

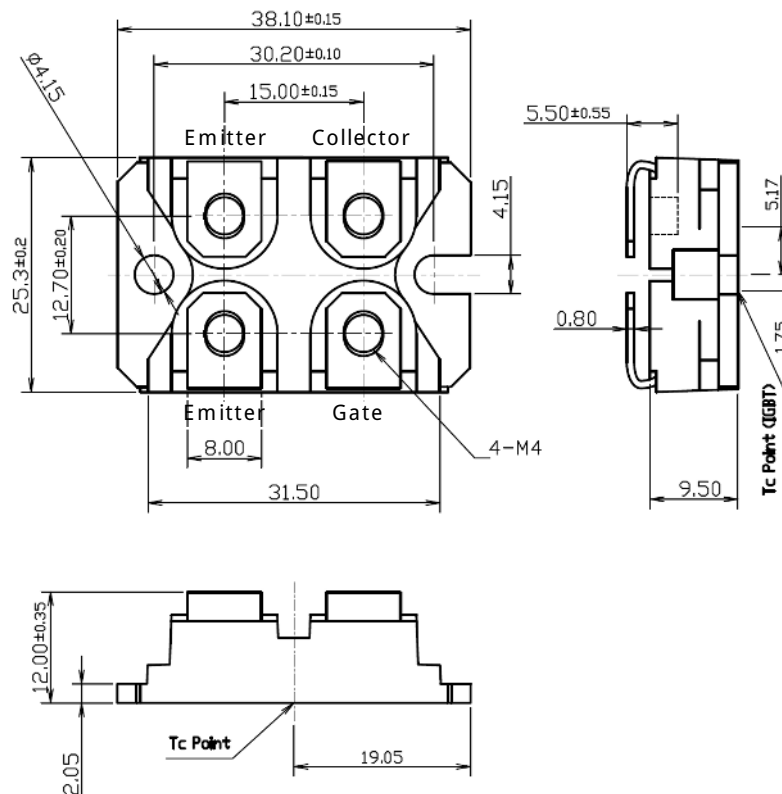

# GSA100AA60



Same package as the product in this photo.

$V_{CES} = 600V$   
 $I_C = 100A$

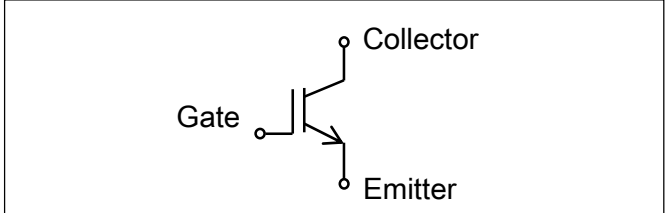

■ IGBT

**Advantages**

- 低  $V_{ce(sat)}$  1.21V Typ 125°C
- SOT-227 標準パッケージ
- 装置の小型化に貢献
- 絶縁耐圧  $V_{iso}=2500V$
- EU RoHS 対応
- UL approved File No.E76102

**Applications**

- AC/DC TIG溶接機, UPS等のバイパスACスイッチ, 表面処理用正逆反転パルス電源

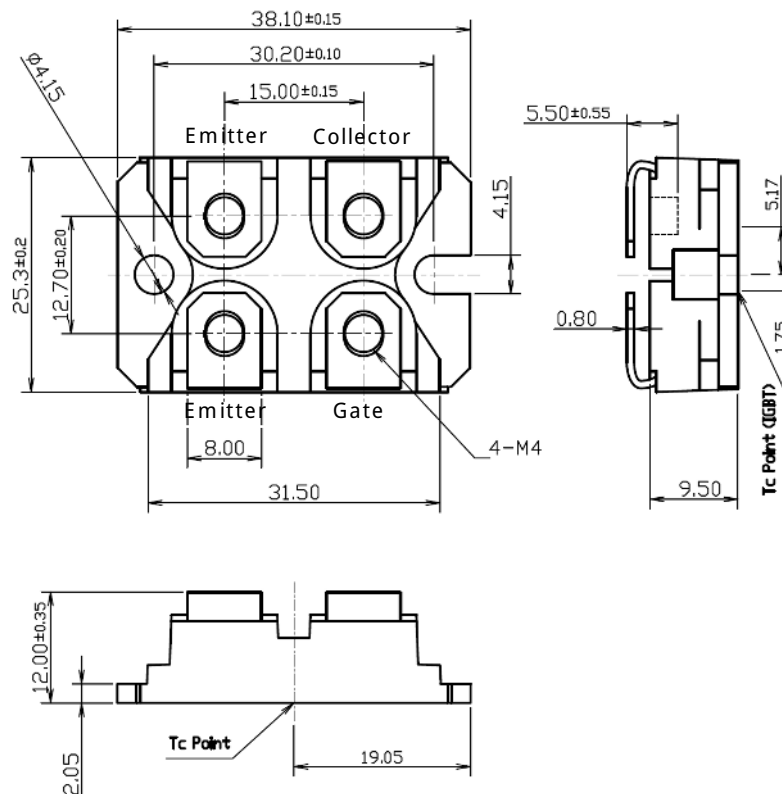

■ Maximum Ratings ( $T_j=25^\circ\text{C}$  unless otherwise specified)

Item	Symbol	Unit	Ratings		Conditions
			Min.	Max.	
Collector - Emitter Voltage	$V_{CES}$	V	600		$V_{GE} = 0\text{ V}$
Gate - Emitter Voltage	$V_{GES}$	V	$\pm 20$		$V_{CE} = 0\text{ V}$
Collector Current	$I_C$	A	100		$V_{GE} = 15\text{ V, D.C., } T_C = 113^\circ\text{C}$
Total Power Dissipation	$P_T$	W	500		$T_C = 25^\circ\text{C}$
Junction Temperature	$T_j$	$^\circ\text{C}$	$-40 \sim +150$		
Storage Temperature	$T_{stg}$	$^\circ\text{C}$	$-40 \sim +125$		
Isolation Voltage	$V_{ISO}$	V	2500		A.C., RMS, 1 minute

■ Electrical Characteristics ( $T_j=25^\circ\text{C}$  unless otherwise specified)

Item	Symbol	Unit	Ratings			Conditions
			Min.	Typ.	Max.	
Gate - Emitter Leakage Current	$I_{GES}$	$\mu\text{A}$			10	$V_{GE} = \pm 20\text{ V, } V_{CE} = 0\text{ V}$
Collector - Emitter Leakage Current	$I_{CES}$	$\mu\text{A}$			100	$V_{CE} = 600\text{ V, } V_{GE} = 0\text{ V}$
					1000	$V_{CE} = 600\text{ V, } V_{GE} = 0\text{ V, } T_j = 125^\circ\text{C}$
Collector - Emitter Breakdown Voltage	$V_{(BR)CES}$	V	600			$V_{GE} = 0\text{ V, } I_C = 100\ \mu\text{A}$
Gate - Emitter Threshold Voltage	$V_{GE(th)}$	V	5.3	6.0	6.7	$V_{CE} = 10\text{ V, } I_C = 10\text{ mA}$
Collector - Emitter Saturation Voltage	$V_{CE(sat)}$	V		1.25	1.50	$I_C = 100\text{ A, } V_{GE} = 15\text{ V}$
				1.21		$I_C = 100\text{ A, } V_{GE} = 15\text{ V, } T_j = 125^\circ\text{C}$
Input Capacitance	$C_{ies}$	nF		6.69		
Output Capacitance	$C_{oes}$	nF		0.90		$V_{CE} = 10\text{ V, } V_{GE} = 0\text{ V, } f = 1\text{ MHz}$
Reverse Transfer Capacitance	$C_{res}$	nF		0.23		

■ Switching Characteristics ( $T_j=25^\circ\text{C}$  unless otherwise specified)

Item	Symbol	Unit	Ratings			Conditions
			Min.	Typ.	Max.	
Total Gate Charge	$Q_g$	nC		224		$I_C = 100\text{ A, } V_{GE}/-V_{GE} = +15/0\text{ V}$ $V_{CE} = 300\text{ V}$
Gate - Emitter Charge	$Q_{ge}$	nC		53		
Gate - Collector Charge	$Q_{gc}$	nC		91		
Turn - On Switching Loss	$E_{on}$	mJ		12.5		$I_C = 100\text{ A, } V_{GE}/-V_{GE} = +15/0\text{ V}$ $V_{CE} = 300\text{ V, } R_G = 330\ \Omega$ *1
Turn - Off Switching Loss	$E_{off}$	mJ		31.0		
Total Switching Loss	$E_{tot}$	mJ		43.5		
Turn - On Delay Time	$t_{d(on)}$	ns		880		
Rise Time	$t_r$	ns		380		
Turn - Off Delay Time	$t_{d(off)}$	ns		7800		
Fall Time	$t_f$	ns		980		$I_C = 100\text{ A, } V_{GE}/-V_{GE} = +15/0\text{ V}$ $V_{CE} = 300\text{ V, } R_G = 330\ \Omega, T_j = 125^\circ\text{C}$ *1
Turn - On Switching Loss	$E_{on}$	mJ		14.0		
Turn - Off Switching Loss	$E_{off}$	mJ		48.5		
Total Switching Loss	$E_{tot}$	mJ		62.5		
Turn - On Delay Time	$t_{d(on)}$	ns		820		
Rise Time	$t_r$	ns		400		
Turn - Off Delay Time	$t_{d(off)}$	ns		8800		
Fall Time	$t_f$	ns		1600		

\*1 : Please refer Fig.1 in page 5 about test circuit.

■ Thermal Characteristics ( $T_j=25^\circ\text{C}$  unless otherwise specified)

Item	Symbol	Unit	Ratings			Conditions
			Min.	Typ.	Max.	
Junction-to-Case Thermal Resistance	$R_{th(j-c)}$	$^\circ\text{C}/\text{W}$			0.25	
Case-to-Heat sink Thermal Resistance	$R_{th(c-f)}$	$^\circ\text{C}/\text{W}$		0.10	0.20	Per module Thermal conductivity = $9 \times 10^{-3} \text{ W}/\text{cm} \cdot ^\circ\text{C}$

■ Mechanical Characteristics ( $T_j=25^\circ\text{C}$  unless otherwise specified)

Item	Symbol	Unit	Ratings			Conditions
			Min.	Typ.	Max.	
Weight	-	g		30		Typical value
Mounting Torque	Mounting M4	-		1.5		Recommended value : 1.0~1.4
	Terminals M4	-	N·m	1.5		Recommended value : 1.0~1.4

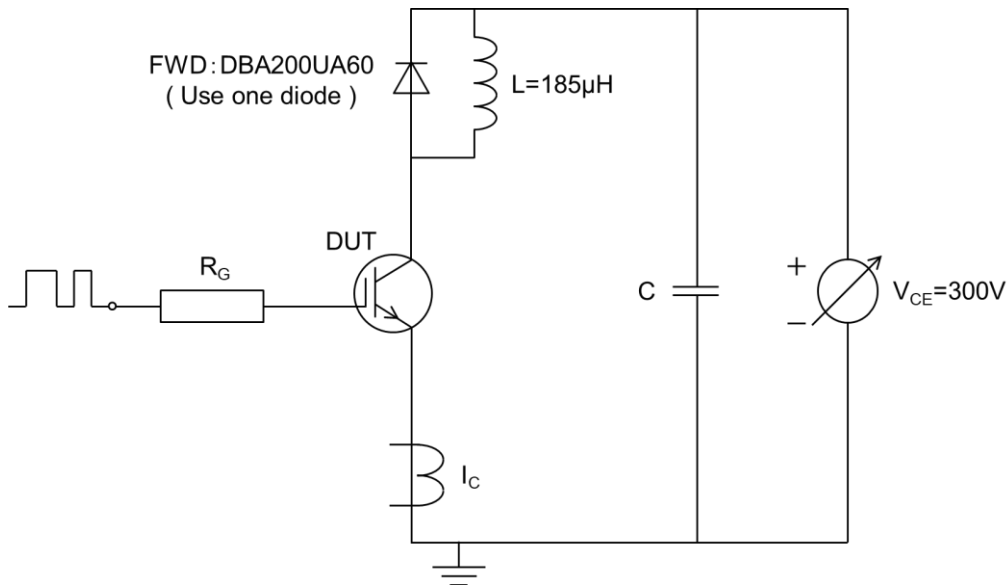

Fig.1 Inductive load switching time test circuit

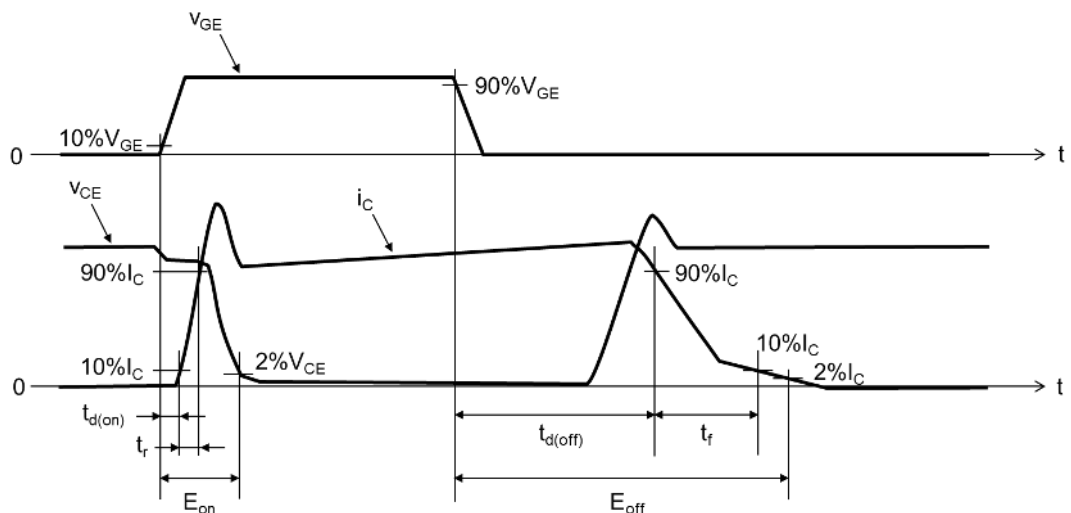
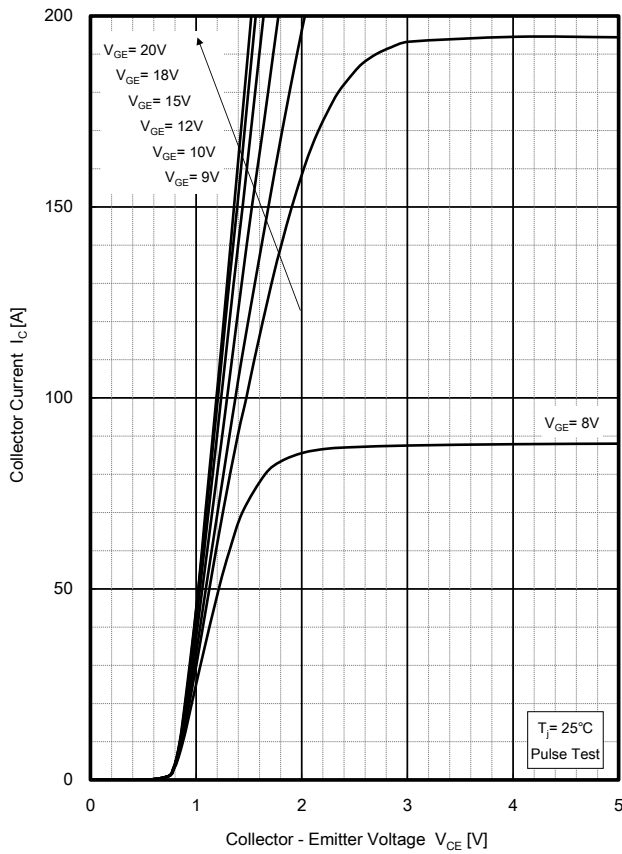
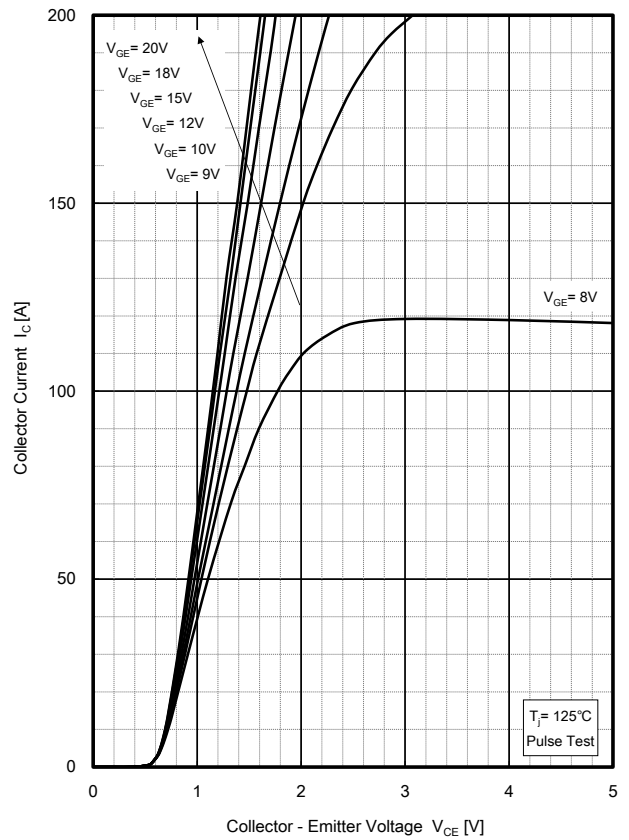

Fig.2 Switching waveform at the time of Inductive load

Output Characteristics (Typ.)



Output Characteristics (Typ.)



Output Characteristics (Typ.)

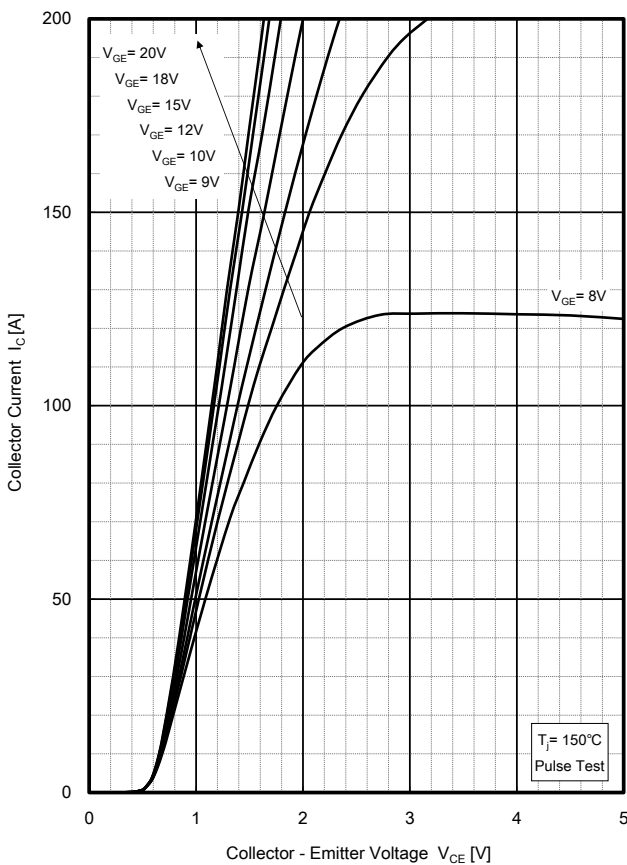

Output Characteristics (Typ.)

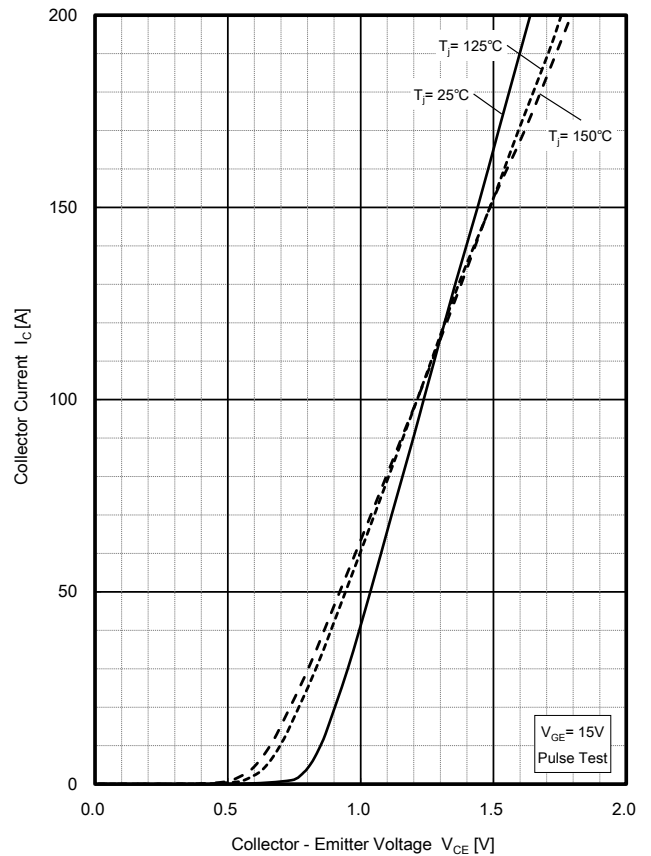

Gate Threshold Voltage Characteristics (Typ.)

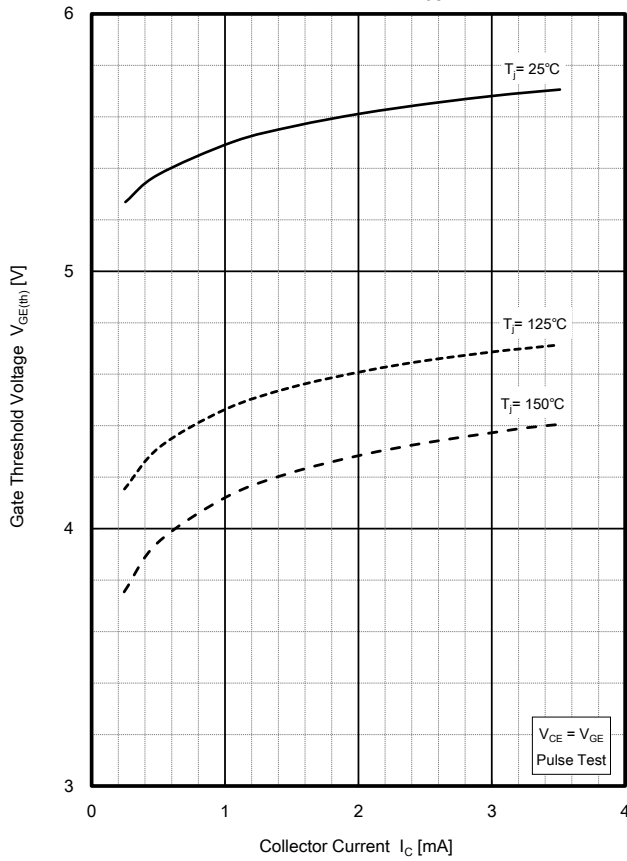

Collector - Emitter Leakage Current Characteristics (Typ.)

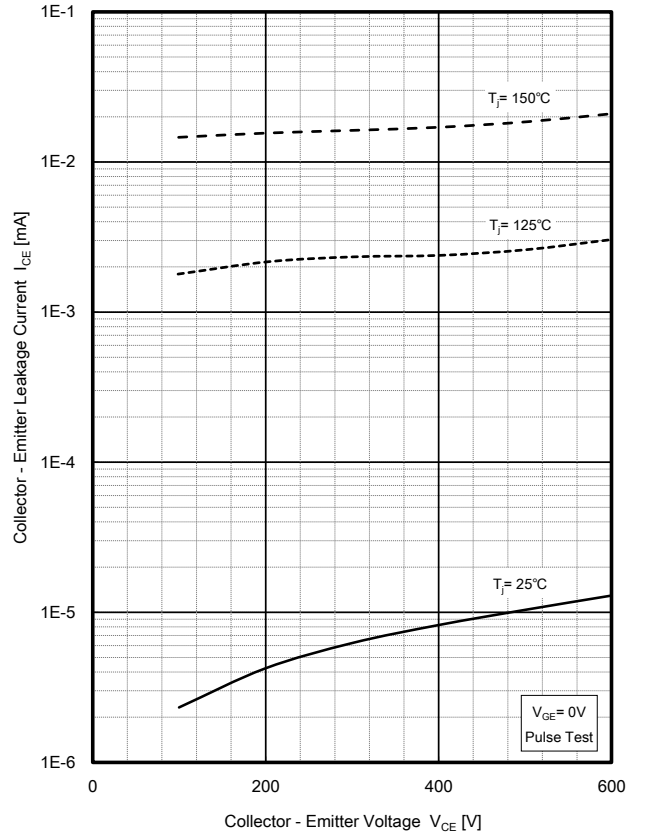

Collector - Emitter Saturation Voltage Characteristics (Typ.)

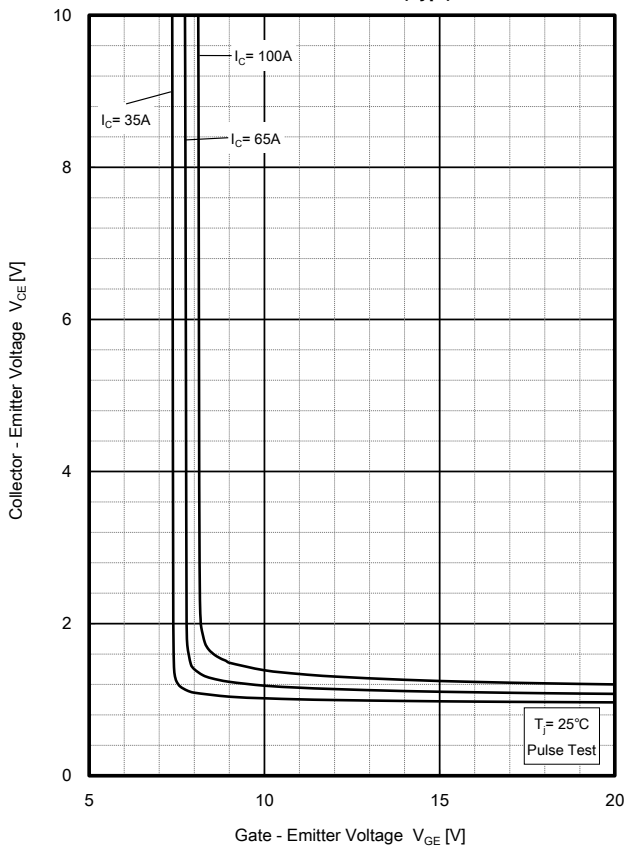

Switching Characteristics (Typ.)

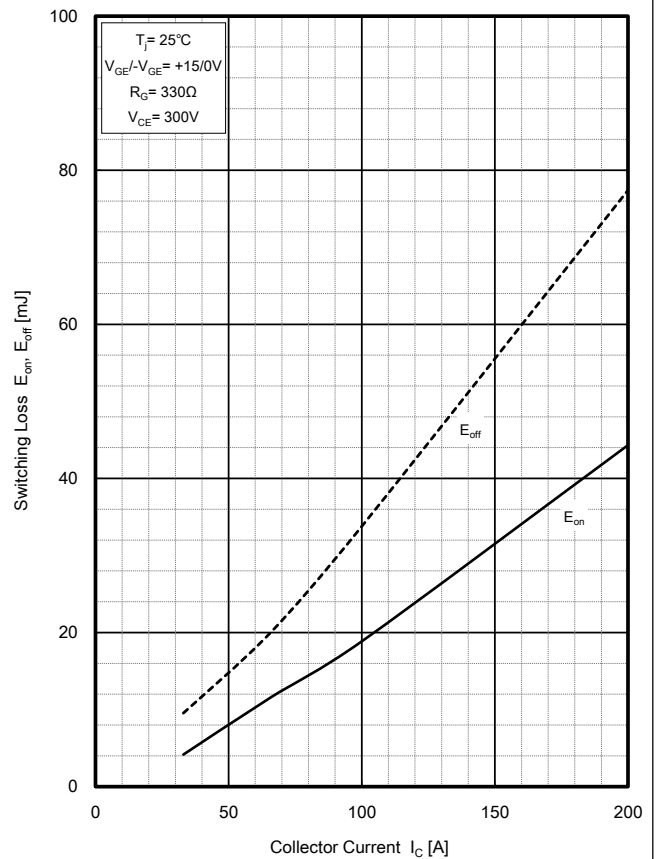

Switching Characteristics (Typ.)

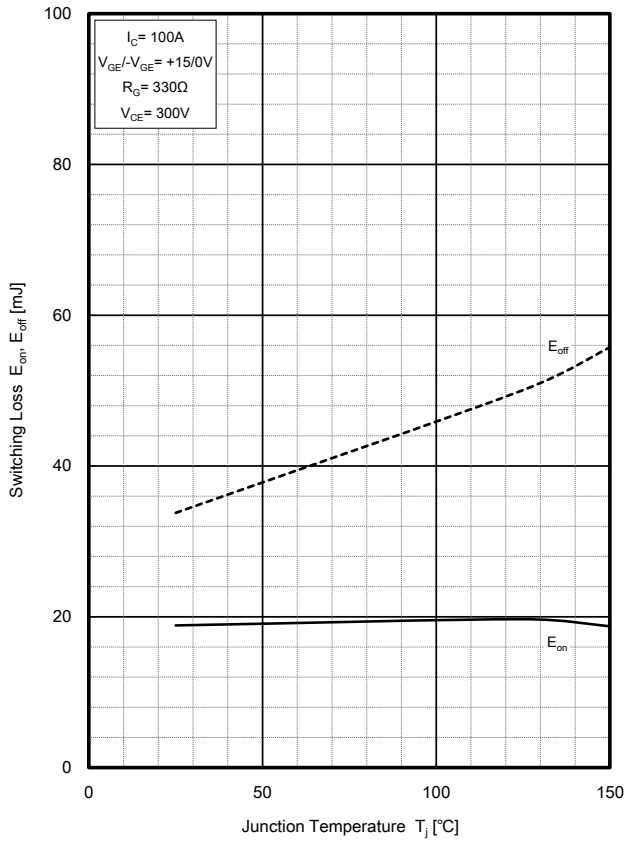

Switching Characteristics (Typ.)

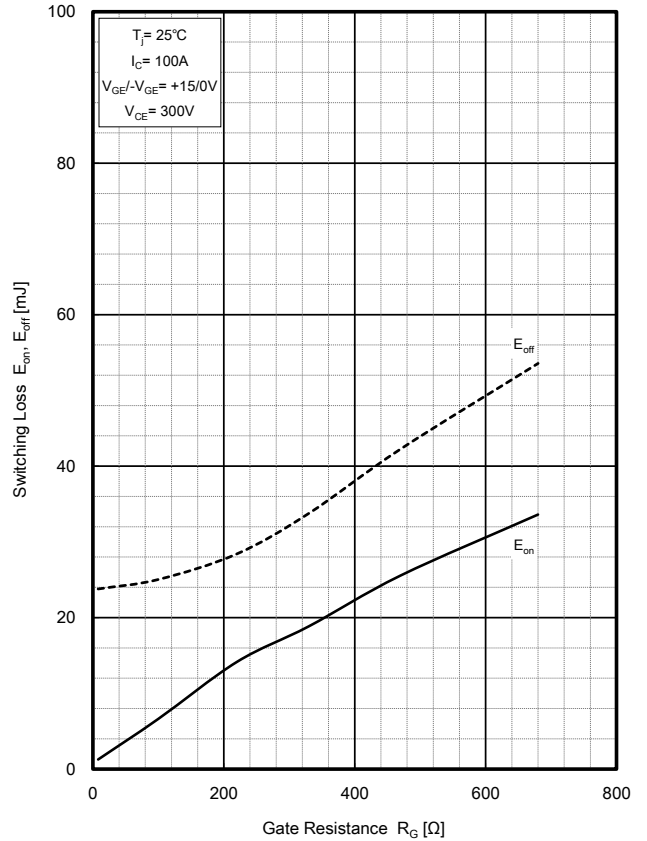

Switching Characteristics (Typ.)

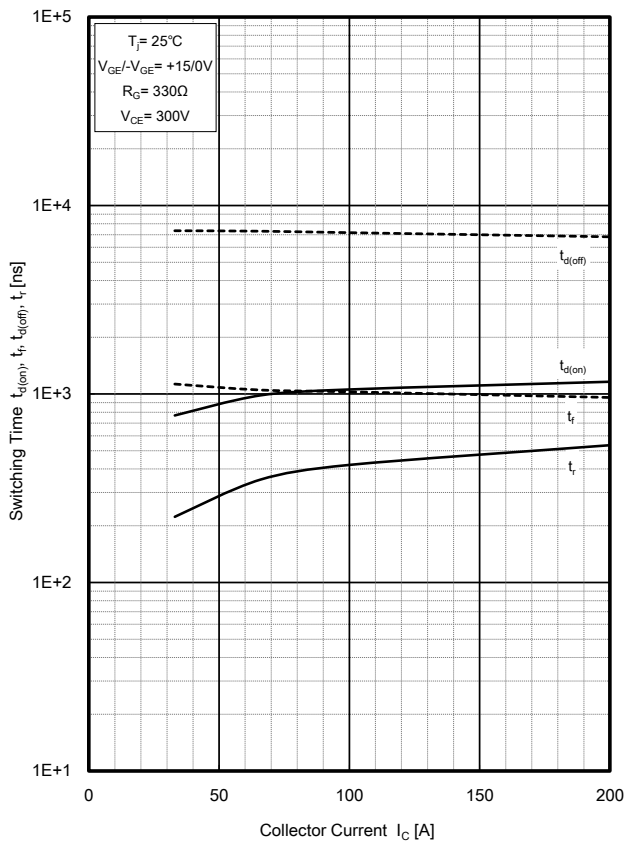

Switching Characteristics (Typ.)

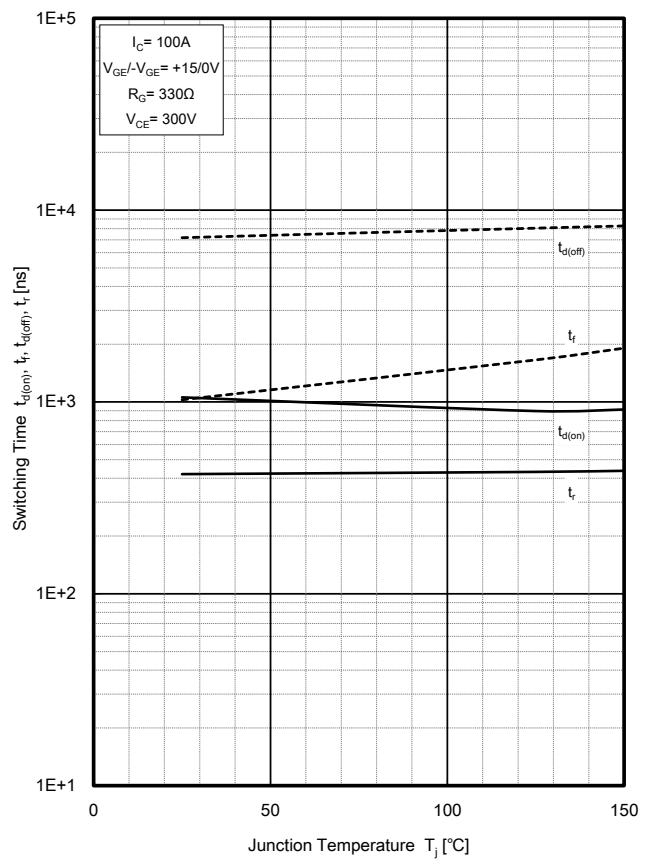



Switching Characteristics (Typ.)

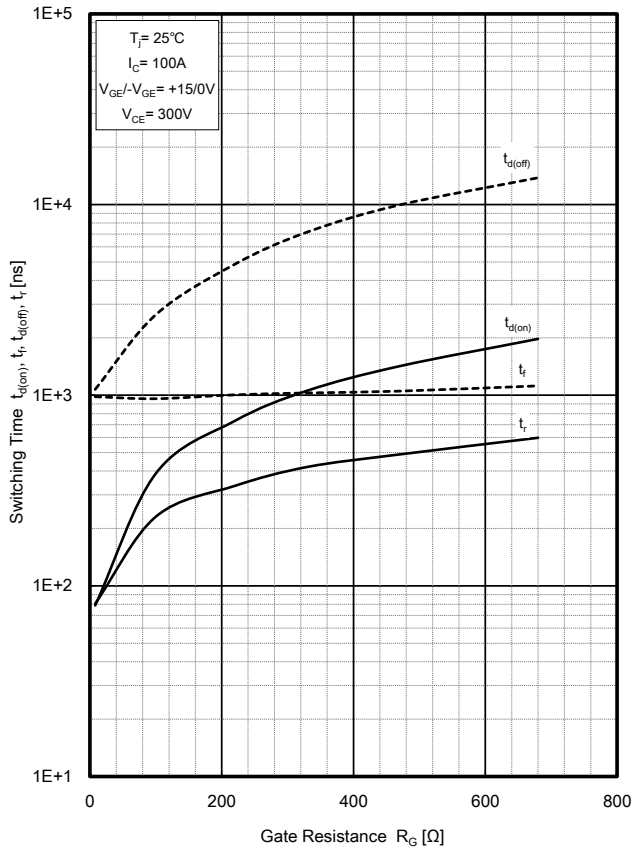

Gate Charge Characteristics (Typ.)

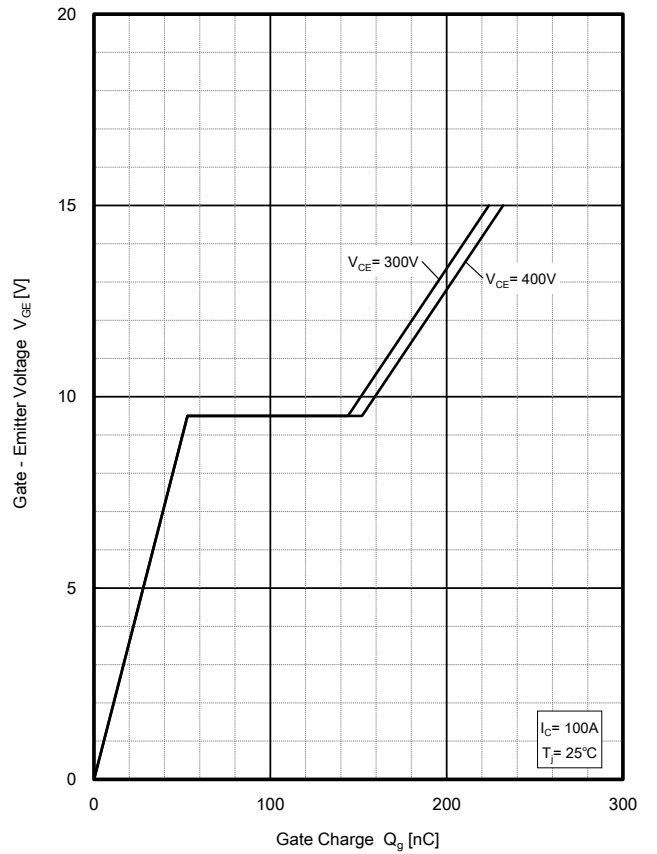

Capacitance Characteristics (Typ.)

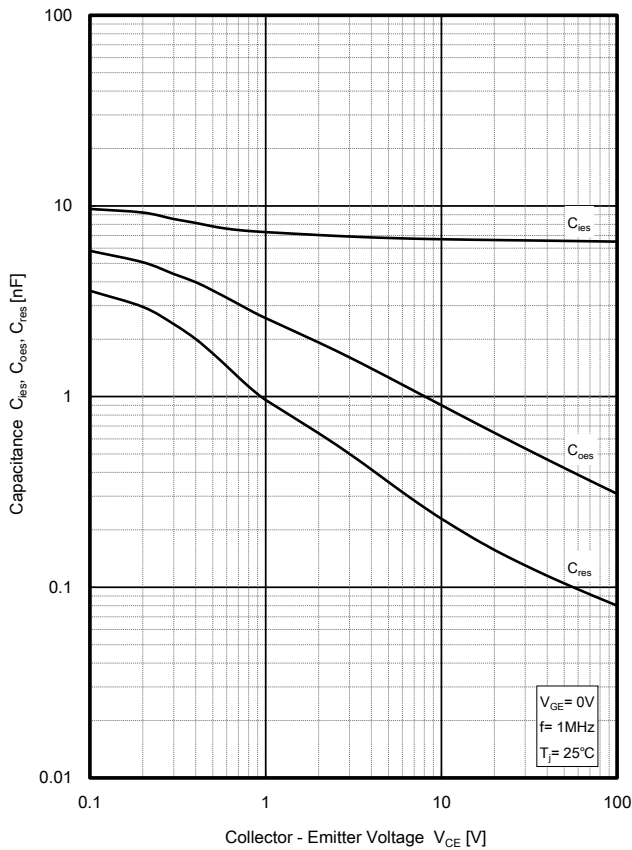

Transient Thermal Impedance  $\theta_{j-c}$  [ $^\circ\text{C}/\text{W}$ ]

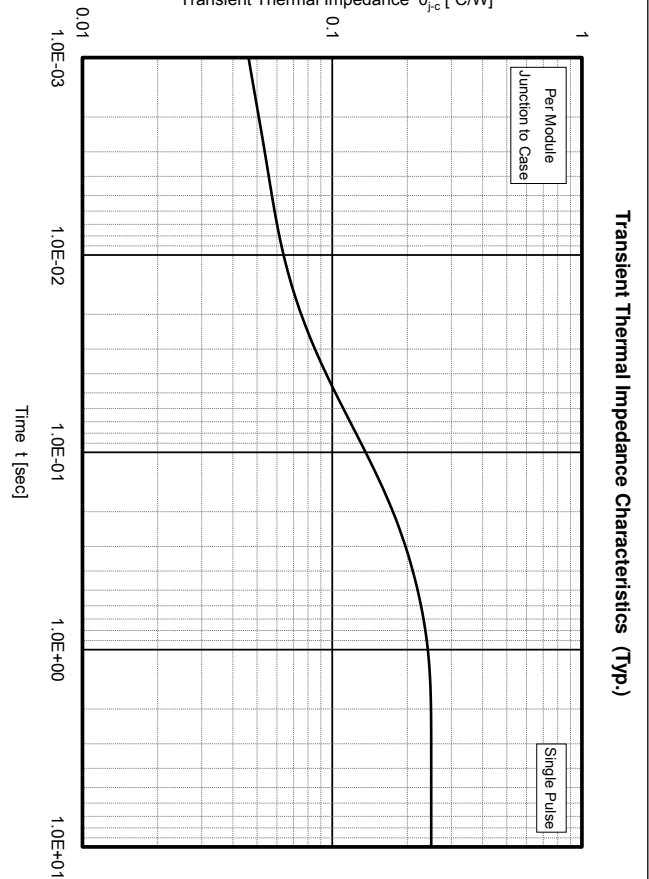



**<Attention>**

- Although we make every effort to improve quality and reliability, semiconductor products may fail or malfunction due to various factors. When using this product, safety measures should be taken for the equipment on which the product will be used, such as redundancy design, design for prevention of the spread of fire, design for prevention of malfunction, etc. in which safety is taken into consideration, so that no accident resulting in personal injury or death, or no damages due to fire, will occur.
- We will not be held responsible for any accidents or damages that have occurred due to use exceeding the rated values or non-observance of precautions.
- If a product described in this material is subject to regulations under the Foreign Exchange and Foreign Trade Act, permission for export is required to be obtained from the Government of Japan under the said Act, in order to export the product.
- Do not use the product for purposes of development, etc. of weapons of mass destruction or for purposes of military utilization, etc.
- Consult us if you have any questions about the product.

**<ご注意>**

- 弊社は品質・信頼性の向上に努めておりますが、半導体製品は様々な要因で故障や誤動作をする場合があります。本製品を使用される場合は、人身事故、火災などによる損害が起こらないようご使用機器での、安全性を考慮した冗長設計、延焼防止設計、誤動作防止設計などの安全措置をとってください。
- 定格を超えるご使用や注意事項を守っていないために生じたいかなる事故や損害に対し、弊社は責任を負うものではありません。
- 本資料に掲載されている製品が、外国為替及び外国貿易法に基づき規制されている場合、輸出には同法に基づく日本国政府の輸出許可が必要です。
- 大量破壊兵器の開発等の目的や、軍事利用等の目的で使用しないでください。
- 製品についてご不明な点は弊社にご照会ください。