

深圳市昱申科技有限公司

CHINA YOUNG SUN LED TECHNOLOGY CO., LTD.

TEL: (86) 755-28079401 28079402 28079403 28079404 28079405

FAX: (86) 755-28079407 E-mail: info@100LED.com Web: www.100LED.com

Model No.: YSL-R596CR3G4B5C-C10
RED/GREEN/BLUE Triple Color LED

Applications:

- Moving Message Display
- Full Color Display
- Banking Board
- Score Boards
- Digital Display

LED Chip Absolute Maximum Ratings: (Ta= 25 °C)

Parameter	Symbol	Red	Green	Blue	Unit
Forward current	I _F	20	20	20	mA
Peak forward current (Duty Cycle=1/10, 10KHz)	I _{PF}	30	30	30	mA
Reverse current (V _R = 5V)	I _R	10	10	10	μ A
Operating temp	T _{OPR}	-25~ 85	-25~ 85	-25~ 85	°C
Storage temp	T _{STG}	-30~ 85	-30~ 85	-30~ 85	°C
Peak Emission Wavelength	λ _{PH}	625	520	467.5	nm

* Soldering Bath: not more than 5 seconds @260 °C. The bottom ends of the plastic reflector should be at least 2mm above the solder surface

Soldering Iron: not more than 3 seconds @300 °C under 30W

LED Chip Typical Electrical & Optical Characteristics: (Ta= 25 °C)

ITEMS	Color	Symbol	Condition	Min.	Typ.	Max.	Unit
Forward Voltage	Red	V _F	I _F = 20mA	1.8	2.0	2.2	V
	Green			3.0	3.2	3.4	
	Blue			3.0	3.2	3.4	
Luminous Intensity	Red	I _v	I _F = 20mA	---	---	800	mcd
	Green			---	---	4000	
	Blue			---	---	900	
Wavelength	Red	Δ λ	I _F = 20mA	620	623	625	nm
	Green			515	517.5	520	
	Blue			465	466	467.5	
Light Degradation after 1000 hours	Red	-4.68% ~ -8.27%					
	Green	-11.37% ~ -15.30%					
	Blue	-8.23% ~ -16.81%					

Address: 5/F, Building B, Anzhilong Indl., Qinghua East Road., Longhua Town, Shenzhen CHINA. 518109

www.100LED.com

ONE HUNDRED LED
 PERFECT LED

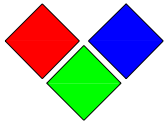

深圳市昱申科技有限公司

CHINA YOUNG SUN LED TECHNOLOGY CO., LTD.

TEL: (86) 755-28079401 28079402 28079403 28079404 28079405

FAX: (86) 755-28079407 E-mail: info@100LED.com Web: www.100LED.com

Light Degradation in mcd: ($I_F = 20\text{mA}$)

Hours Colors	Light Degradation in mcd after Different Hours					
	216 Hrs	360 Hrs	792 Hrs	1104 Hrs	1992 Hrs	2328 Hrs
Red	1.52%	-1.22%	-3.10%	-4.68%	-5.72%	-8.27%
Green	-8.02%	-9.78%	-10.25%	-11.37%	-13.79%	-15.30%
Blue	3.13%	-0.33%	-3.84%	-8.23%	-14.32%	-16.81%

Mechanical Dimensions:

- All dimension are in mm, tolerance is $\pm 0.2\text{mm}$ unless otherwise noted
- An epoxy meniscus may extend about 1.5mm down the leads.
- Burr around bottom of epoxy may be 0.5mm Maximum

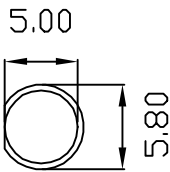

Unit: mm

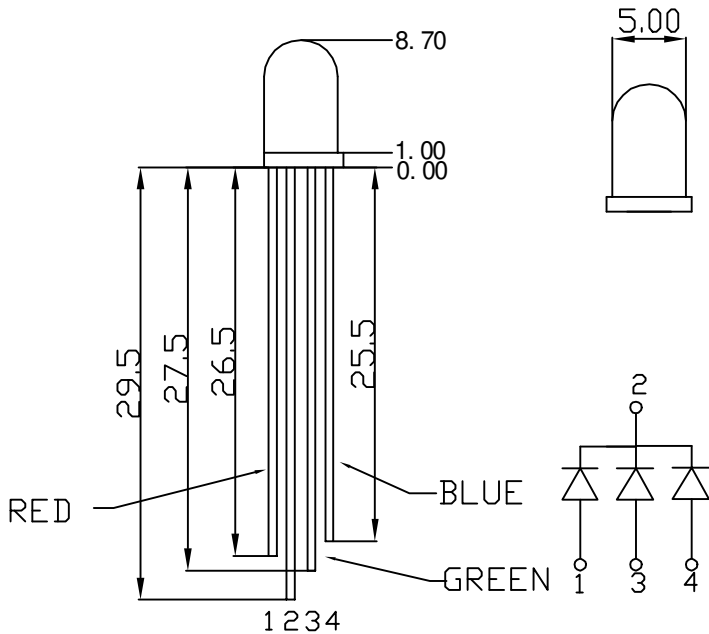

Viewing Angle Drawing

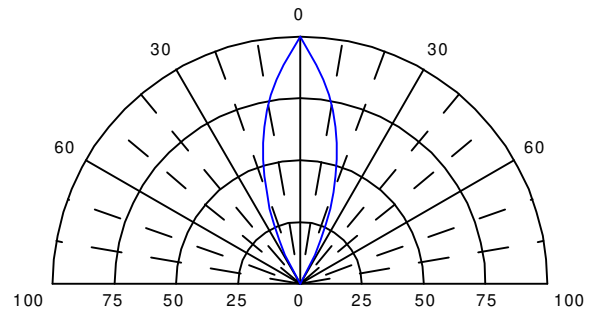

Address: 5/F, Building B, AnzhiLong Indl., Qinghua East Road., Longhua Town, Shenzhen CHINA. 518109

www.100LED.com

ONE HUNDRED LED
PERFECT LED

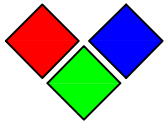

深圳市昱申科技有限公司

CHINA YOUNG SUN LED TECHNOLOGY CO., LTD.

TEL: (86) 755-28079401 28079402 28079403 28079404 28079405

FAX: (86) 755-28079407 E-mail: info@100LED.com Web: www.100LED.com

Packing Information:

1. Anti-static bag

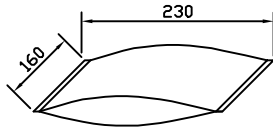

Unit: mm

200 - 500 pcs per bag

With 1 little bag of drier inside

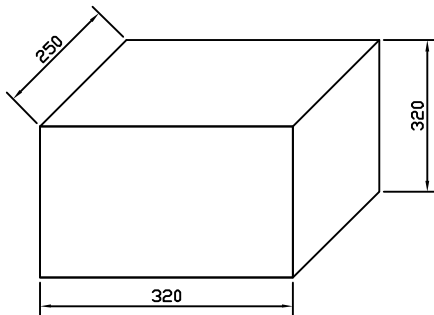

Middle Box

30 - 40 bags per box

15-20K pcs per box

Anti-static Tube Packaging Information:

Unit: mm

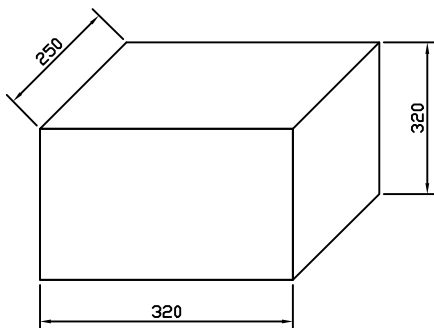
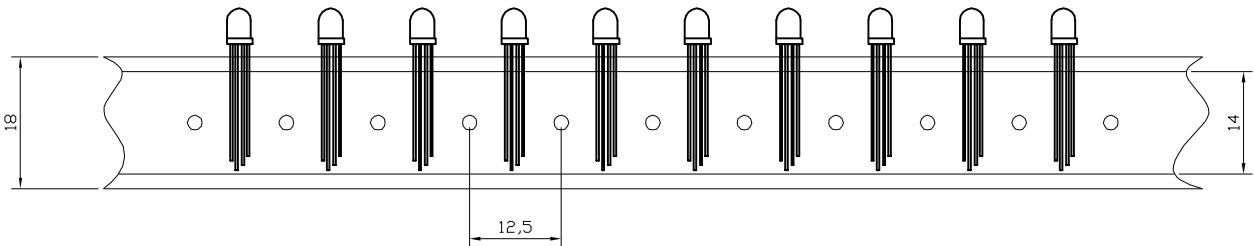

Middle Box

Taping dimension can be adjusted to customer's requirements.

8-10 Layers per box

16K-20K pcs per box

Address: 5/F, Building B, Anzhilong Indl., Qinghua East Road., Longhua Town, Shenzhen CHINA. 518109

www.100LED.com

ONE HUNDRED LED
PERFECT LED

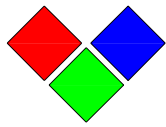

深圳市昱申科技有限公司

CHINA YOUNG SUN LED TECHNOLOGY CO., LTD.

TEL: (86) 755-28079401 28079402 28079403 28079404 28079405

FAX: (86) 755-28079407 E-mail: info@100LED.com Web: www.100LED.com

Code System:

YSL-R596CR3G4B5C-C10

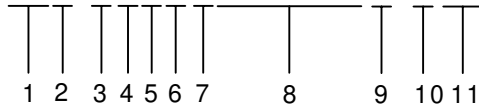

1. Company Code, short for Young Sun

2. Code for LED series.

3. Code for LED Type.

R: Round B: Bullet C: Columnar O: Oval
H: Helmet Q: Square V: Concave P: Pagoda
S: Strawhat D: Special

4. Code for LED Lens Type.

5. Code for Lead Frame of LED

6. Code for Lead Frame Code of LED

7. Code for polarity(A: Anode C: Cathode)

8. Code for Wavelength Color

9. Code for Lens color

C: Water Clear W: White Diffused D: Color Diffused T: Color Transparent

10. Code for Viewing Angle

A: 0-10 B: 10-20 C: 20-30 D: 30-40 E: 40-60 F: 60-90 G: 90-120 H: >120

11. Luminous Intensity Grade:

Warranty:

In order to make the LEDs lifespan longer, please set the input current below 20mA.

Electrical & Optical Characteristics consistency of same items all shipments.

Notes:

Please use LEDs based on our datasheet.

LED is sensitive to statics, be sure your equipments are anti-static when you use our LEDs.

Pay more attention to your heat dissipation system when you use it, the better heat dissipation, the longer LED lifespan.

Address: 5/F, Building B, Anzhihong Indl., Qinghua East Road., Longhua Town, Shenzhen CHINA. 518109

www.100LED.com

ONE HUNDRED LED
PERFECT LED