

Rochester Electronics Manufactured Components

Rochester branded components are manufactured using either die/wafers purchased from the original suppliers or Rochester wafers recreated from the original IP. All recreations are done with the approval of the OCM.

Parts are tested using original factory test programs or Rochester developed test solutions to guarantee product meets or exceed the OCM data sheet.

Quality Overview

- ISO-9001
- AS9120 certification
- Qualified Manufacturers List (QML) MIL-PRF-35835
 - Class Q Military
 - Class V Space Level
- Qualified Suppliers List of Distributors (QSLD)
 - Rochester is a critical supplier to DLA and meets all industry and DLA standards.

Rochester Electronics, LLC is committed to supplying products that satisfy customer expectations for quality and are equal to those originally supplied by industry manufacturers.

The original manufacturer's datasheet accompanying this document reflects the performance and specifications of the Rochester manufactured version of this device. Rochester Electronics guarantees the performance of its semiconductor products to the original OEM specifications. 'Typical' values are for reference purposes only. Certain minimum or maximum ratings may be based on product characterization, design, simulation, or sample testing.



8254 PROGRAMMABLE INTERVAL TIMER

- Compatible with All Intel and Most Other Microprocessors
- Handles Inputs from DC to 10 MHz
 - 8 MHz 8254
 - 10 MHz 8254-2
- Status Read-Back Command
- Six Programmable Counter Modes
- Three Independent 16-Bit Counters
- Binary or BCD Counting
- Single +5V Supply
- Available in EXPRESS
 - Standard Temperature Range

The Intel 8254 is a counter/timer device designed to solve the common timing control problems in microcomputer system design. It provides three independent 16-bit counters, each capable of handling clock inputs up to 10 MHz. All modes are software programmable. The 8254 is a superset of the 8253.

The 8254 uses HMOS technology and comes in a 24-pin plastic or CERDIP package.

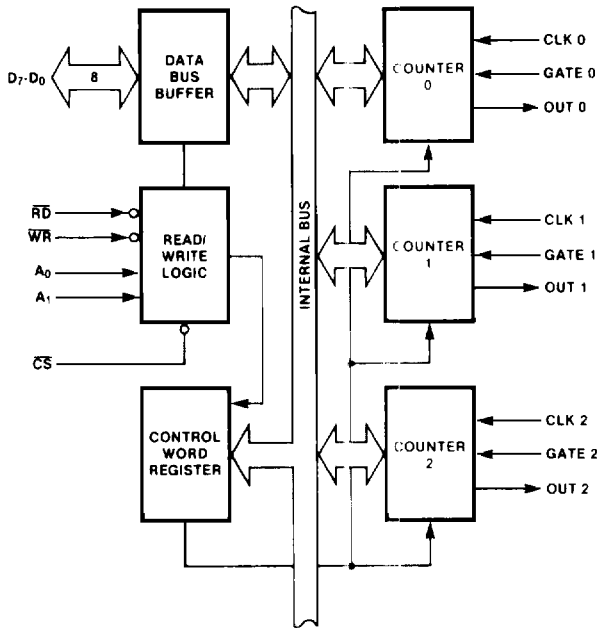

Figure 1. 8254 Block Diagram

231164-1

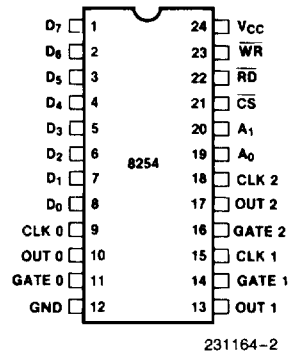

Figure 2. Pin Configuration



The complete document for this product is available on Intel's "Data-on-Demand" CD-ROM product. Contact your local Intel field sales office, Intel technical distributor, or call 1-800-548-4725.