

THIS DRAWING IS UNPUBLISHED. RELEASED FOR PUBLICATION, 19 .
 © COPYRIGHT 19 BY AMP INCORPORATED. ALL INTERNATIONAL RIGHTS RESERVED.

| LOC | DIST | P | F | REVISIONS | | | | |
|-----|------|---|---|-----------|-----|-----------------------------|----------|------|
| | | | | ZONE | LTR | DESCRIPTION | DATE | APPD |
| AR | 39 | | | 0 | | RELEASED TO CUST AR2289 | 1-89 | - |
| | | | | A | | SUPSD -2 PER EC 0020-542-94 | 12/21/94 | GM |

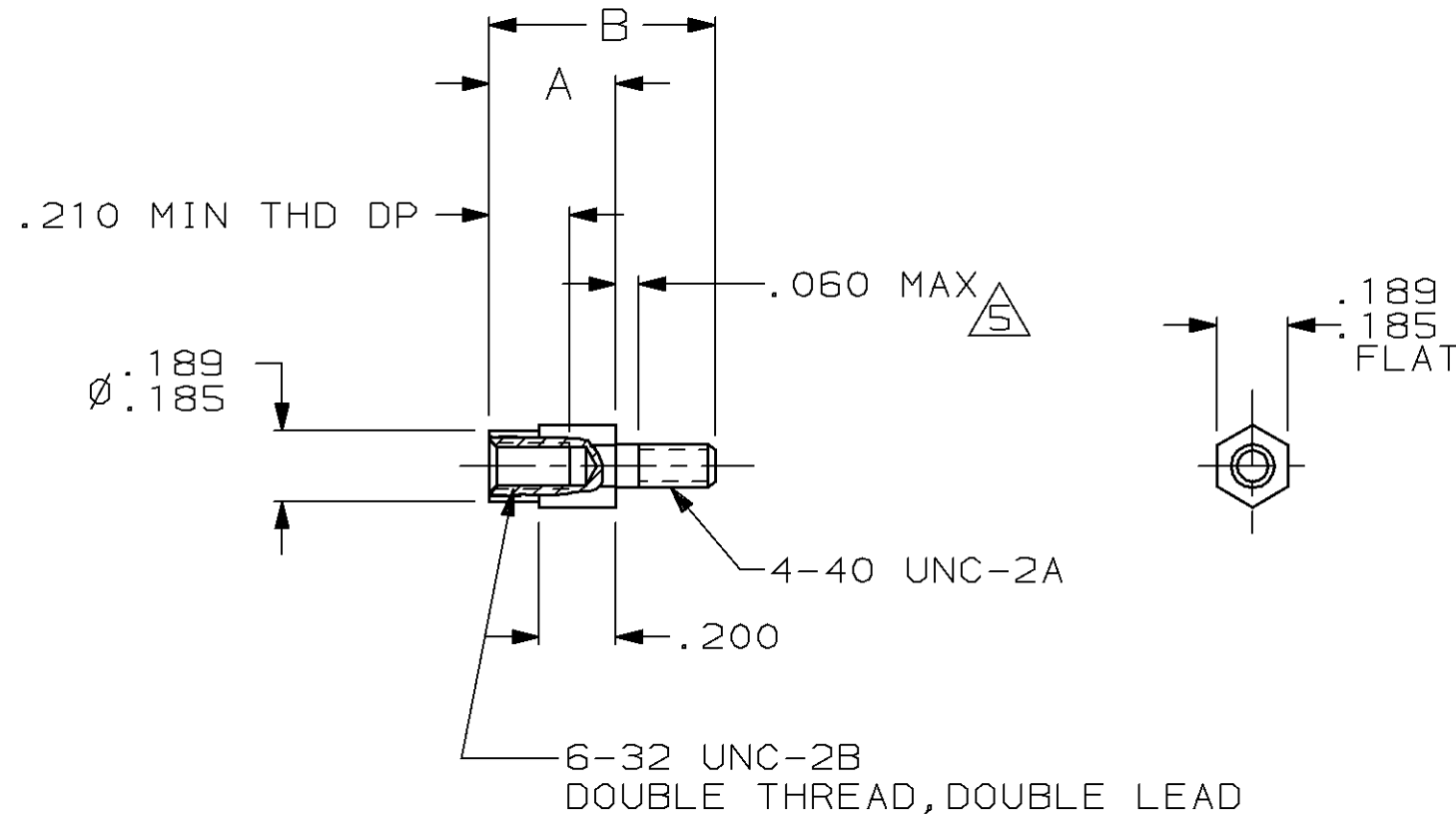

- 1 STAINLESS STEEL
- 2 CARBON STEEL
- 3 PASSIVATED
- 4 ZINC PLATED PER QQ-Z-325, CLASS 3, TYPE II
- 5 NO THREAD REQUIRED THIS LENGTH.

| | B | A | FINISH | MATERIAL | PART NO. |
|------------------|------|------|--------|----------|----------|
| OBSOLETE | .680 | .420 | 4 | 2 | 86937-6 |
| | | | | | |
| | .589 | .330 | 3 | 1 | 86937-3 |
| SUPSD BY 86937-3 | .589 | .330 | 4 | 2 | 86937-2 |

| | | | | |
|--|----------------------------|-----------------------------|--|---------------------|
| DO NOT SCALE PRINT. UNLESS SPECIFIED DIMENSIONS IN INCHES. TOLERANCES ON: 2 PLC DEC ± - 3 PLC DEC ± .005 ANGLES ± - | | DR 1-26-89 C. OBERMAN | AMP AMP INCORPORATED Harrisburg, Pa. 17105 | |
| MATERIAL SEE TABLE | CHK 2-15-89 G.D. MILLER | APPD 2-15-89 G.D. MILLER | | |
| FINISH SEE TABLE | APPD 2-15-89 W. PARKER | PRODUCT SPEC - | SIZE B | FSCM NO 00779 |
| | APPLICATION SPEC - | WEIGHT - | SCALE 2:1 | DRAWING NO 86937 |
| | | | SHEET 1 OF 1 | |