

74AHC259-Q100; 74AHCT259-Q100

8-bit addressable latch

Rev. 1 — 22 July 2013

Product data sheet

1. General description

The 74AHC259-Q100; 74AHCT259-Q100 is a high-speed Si-gate CMOS device and is pin compatible with Low-power Schottky TTL (LSTTL). It is specified in compliance with JEDEC standard No. 7-A.

The 74AHC259-Q100; 74AHCT259-Q100 is a high-speed 8-bit addressable latch designed for general purpose storage applications in digital systems. It is a multifunctional device capable of storing single-line data in eight addressable latches. It provides a 3-to-8 decoder and multiplexer function with active HIGH outputs (Q0 to Q7). It also incorporates an active LOW common reset (\overline{MR}) for resetting all latches as well as an active LOW enable input (\overline{LE}).

The 74AHC259-Q100; 74AHCT259-Q100 has four modes of operation:

- In the addressable latch mode, data on the data line (D) is written into the addressed latch. The addressed latch follows the data input with all non-addressed latches remaining in their previous states.
- In the memory mode, all latches remain in their previous states and are unaffected by the data or address inputs.
- In the 3-to-8 decoding or demultiplexing mode, the addressed output follows the state of the data input (D) with all other outputs in the LOW state.
- In the reset mode, all outputs are LOW and unaffected by the address inputs (A0 to A2) and data input (D).

When operating the 74AHC259-Q100; 74AHCT259-Q100 as an address latch, changing more than 1 bit of the address could impose a transient-wrong address. Therefore, only change more than 1 bit while in the memory mode.

This product has been qualified to the Automotive Electronics Council (AEC) standard Q100 (Grade 1) and is suitable for use in automotive applications.

2. Features and benefits

- Automotive product qualification in accordance with AEC-Q100 (Grade 1)
 - ◆ Specified from $-40\text{ }^{\circ}\text{C}$ to $+85\text{ }^{\circ}\text{C}$ and from $-40\text{ }^{\circ}\text{C}$ to $+125\text{ }^{\circ}\text{C}$
- Balanced propagation delays
- All inputs have Schmitt-trigger actions
- Combines demultiplexer and 8-bit latch
- Serial-to-parallel capability



- Output from each storage bit available
- Random (addressable) data entry
- Easily expandable
- Common reset input
- Useful as a 3-to-8 active HIGH decoder
- Inputs accept voltages higher than V_{CC}
- Input levels:
 - ◆ For 74AHC259-Q100: CMOS level
 - ◆ For 74AHCT259-Q100: TTL level
- ESD protection:
 - ◆ MIL-STD-883, method 3015 exceeds 2000 V
 - ◆ HBM JESD22-A114F exceeds 2000 V
 - ◆ MM JESD22-A115-A exceeds 200 V ($C = 200 \text{ pF}$, $R = 0 \text{ } \Omega$)
- Multiple package options

3. Ordering information

Table 1. Ordering information

Type number	Package			
	Temperature range	Name	Description	Version
74AHC259-Q100				
74AHC259D-Q100	-40 °C to +125 °C	SO16	plastic small outline package; 16 leads; body width 3.9 mm	SOT109-1
74AHC259PW-Q100	-40 °C to +125 °C	TSSOP16	plastic thin shrink small outline package; 16 leads; body width 4.4 mm	SOT403-1
74AHCT259-Q100				
74AHCT259D-Q100	-40 °C to +125 °C	SO16	plastic small outline package; 16 leads; body width 3.9 mm	SOT109-1
74AHCT259PW-Q100	-40 °C to +125 °C	TSSOP16	plastic thin shrink small outline package; 16 leads; body width 4.4 mm	SOT403-1

4. Functional diagram

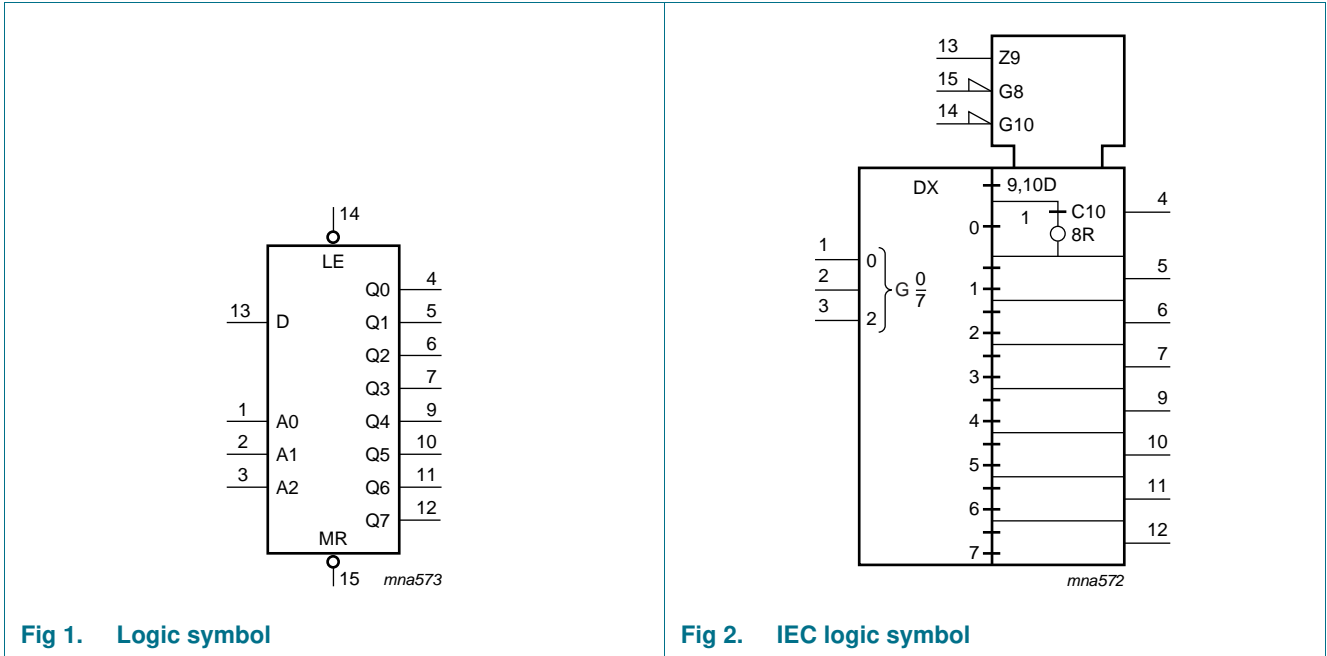

Fig 1. Logic symbol

Fig 2. IEC logic symbol

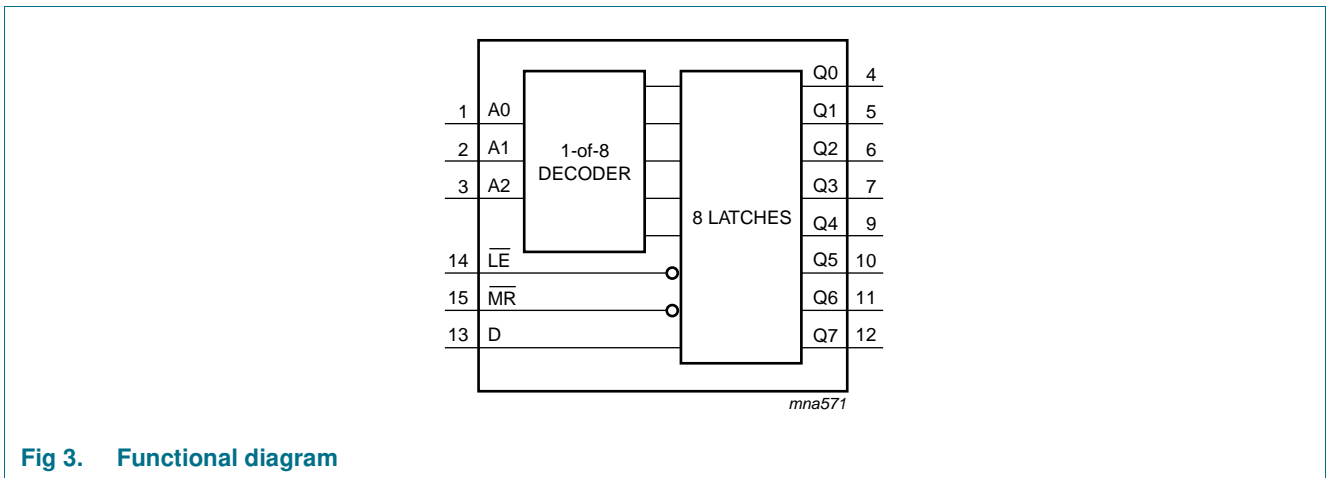

Fig 3. Functional diagram

5. Pinning information

5.1 Pinning

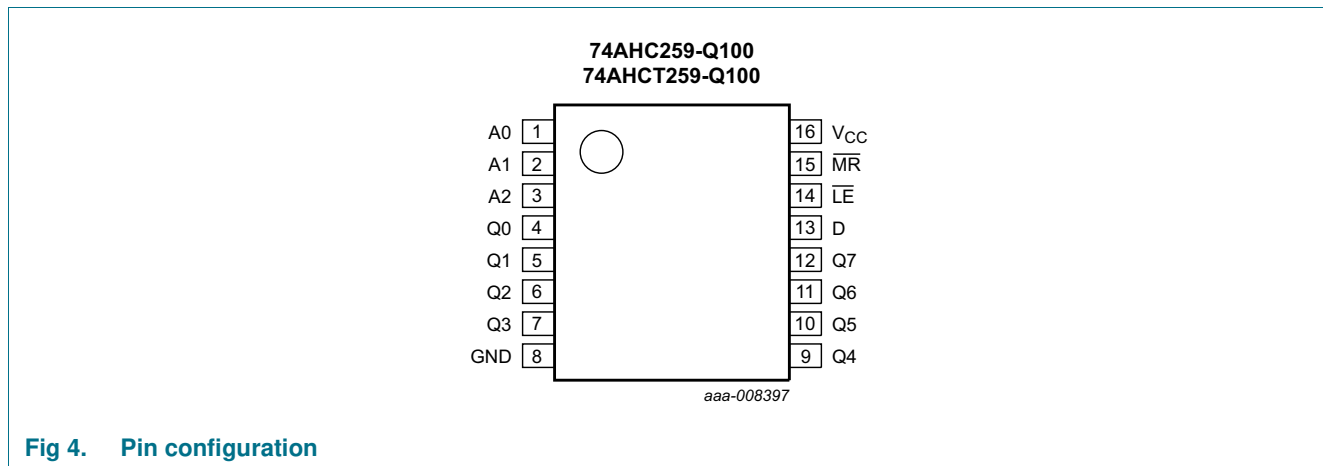

Fig 4. Pin configuration

5.2 Pin description

Table 2. Pin description

Symbol	Pin	Description
A0	1	address input
A1	2	address input
A2	3	address input
Q0	4	latch output
Q1	5	latch output
Q2	6	latch output
Q3	7	latch output
GND	8	ground (0 V)
Q4	9	latch output
Q5	10	latch output
Q6	11	latch output
Q7	12	latch output
D	13	data input
$\overline{\text{LE}}$	14	latch enable input (active LOW)
$\overline{\text{MR}}$	15	conditional reset input (active LOW)
V _{CC}	16	supply voltage

6. Functional description

Table 3. Function table^[1]

Operating mode	Input						Output							
	$\overline{\text{MR}}$	$\overline{\text{LE}}$	D	A0	A1	A2	Q0	Q1	Q2	Q3	Q4	Q5	Q6	Q7
Reset (clear)	L	H	X	X	X	X	L	L	L	L	L	L	L	L
Demultiplexer (active HIGH 8-channel) decoder (when D = H)	L	L	d	L	L	L	Q = d	L	L	L	L	L	L	L
			d	H	L	L	L	Q = d	L	L	L	L	L	L
			d	L	H	L	L	L	Q = d	L	L	L	L	L
			d	H	H	L	L	L	L	Q = d	L	L	L	L
			d	L	L	H	L	L	L	L	Q = d	L	L	L
			d	H	L	H	L	L	L	L	L	Q = d	L	L
			d	L	H	H	L	L	L	L	L	L	Q = d	L
			d	H	H	H	L	L	L	L	L	L	L	L
Memory (no action)	H	H	X	X	X	X	q ₀	q ₁	q ₂	q ₃	q ₄	q ₅	q ₆	q ₇
Addressable latch	H	L	d	L	L	L	Q = d	q ₁	q ₂	q ₃	q ₄	q ₅	q ₆	q ₇
			d	H	L	L	q ₀	Q = d	q ₂	q ₃	q ₄	q ₅	q ₆	q ₇
			d	L	H	L	q ₀	q ₁	Q = d	q ₃	q ₄	q ₅	q ₆	q ₇
			d	H	H	L	q ₀	q ₁	q ₂	Q = d	q ₄	q ₅	q ₆	q ₇
			d	L	L	H	q ₀	q ₁	q ₂	q ₃	Q = d	q ₅	q ₆	q ₇
			d	H	L	H	q ₀	q ₁	q ₂	q ₃	q ₄	Q = d	q ₆	q ₇
			d	L	H	H	q ₀	q ₁	q ₂	q ₃	q ₄	q ₅	Q = d	q ₇
			H	H	H	H	q ₀	q ₁	q ₂	q ₃	q ₄	q ₅	q ₆	Q = d

[1] H = HIGH voltage level;

L = LOW voltage level;

X = don't care;

d = HIGH or LOW data one set-up time prior to the LOW-to-HIGH $\overline{\text{LE}}$ transition;

q = lower case letter indicates the state of the referenced input one set-up time prior to the LOW-to-HIGH transition.

Table 4. Operating mode select table^[1]

LE	MR	Mode
L	H	addressable latch
H	H	memory
L	L	active HIGH 8-channel demultiplexer
H	L	reset

[1] H = HIGH voltage level; L = LOW voltage level.

7. Limiting values

Table 5. Limiting values

In accordance with the Absolute Maximum Rating System (IEC 60134). Voltages are referenced to GND (ground = 0 V).

Symbol	Parameter	Conditions	Min	Max	Unit
V_{CC}	supply voltage		-0.5	+7.0	V
V_I	input voltage		-0.5	+7.0	V
I_{IK}	input clamping current	$V_I < -0.5$ V	^[1] -20	-	mA
I_{OK}	output clamping current	$V_O < -0.5$ V or $V_O > V_{CC} + 0.5$ V	^[1] -20	+20	mA
I_O	output current	$V_O = -0.5$ V to $(V_{CC} + 0.5$ V)	-25	+25	mA
I_{CC}	supply current		-	+75	mA
I_{GND}	ground current		-75	-	mA
T_{stg}	storage temperature		-65	+150	°C
P_{tot}	total power dissipation	$T_{amb} = -40$ °C to +125 °C	^[2] -	500	mW

[1] The input and output voltage ratings may be exceeded if the input and output current ratings are observed.

[2] For SO16 packages: above 70 °C the value of P_{tot} derates linearly at 8 mW/K.
For TSSOP16 packages: above 60 °C the value of P_{tot} derates linearly at 5.5 mW/K.

8. Recommended operating conditions

Table 6. Operating conditions

Symbol	Parameter	Conditions	Min	Typ	Max	Unit
74AHC259-Q100						
V_{CC}	supply voltage		2.0	5.0	5.5	V
V_I	input voltage		0	-	5.5	V
V_O	output voltage		0	-	V_{CC}	V
T_{amb}	ambient temperature		-40	+25	+125	°C
$\Delta t/\Delta V$	input transition rise and fall rate	$V_{CC} = 3.0$ V to 3.6 V	-	-	100	ns/V
		$V_{CC} = 4.5$ V to 5.5 V	-	-	20	ns/V
74AHCT259-Q100						
V_{CC}	supply voltage		4.5	5.0	5.5	V
V_I	input voltage		0	-	5.5	V
V_O	output voltage		0	-	V_{CC}	V
T_{amb}	ambient temperature		-40	+25	+125	°C
$\Delta t/\Delta V$	input transition rise and fall rate	$V_{CC} = 4.5$ V to 5.5 V	-	-	20	ns/V

9. Static characteristics

Table 7. Static characteristics

At recommended operating conditions; voltages are referenced to GND (ground = 0 V).

Symbol	Parameter	Conditions	25 °C			-40 °C to +85 °C		-40 °C to +125 °C		Unit
			Min	Typ	Max	Min	Max	Min	Max	
74AHC259-Q100										
V _{IH}	HIGH-level input voltage	V _{CC} = 2.0 V	1.5	-	-	1.5	-	1.5	-	V
		V _{CC} = 3.0 V	2.1	-	-	2.1	-	2.1	-	V
		V _{CC} = 5.5 V	3.85	-	-	3.85	-	3.85	-	V
V _{IL}	LOW-level input voltage	V _{CC} = 2.0 V	-	-	0.5	-	0.5	-	0.5	V
		V _{CC} = 3.0 V	-	-	0.9	-	0.9	-	0.9	V
		V _{CC} = 5.5 V	-	-	1.65	-	1.65	-	1.65	V
V _{OH}	HIGH-level output voltage	V _I = V _{IH} or V _{IL}								
		I _O = -50 μA; V _{CC} = 2.0 V	1.9	2.0	-	1.9	-	1.9	-	V
		I _O = -50 μA; V _{CC} = 3.0 V	2.9	3.0	-	2.9	-	2.9	-	V
		I _O = -50 μA; V _{CC} = 4.5 V	4.4	4.5	-	4.4	-	4.4	-	V
		I _O = -4.0 mA; V _{CC} = 3.0 V	2.58	-	-	2.48	-	2.40	-	V
	I _O = -8.0 mA; V _{CC} = 4.5 V	3.94	-	-	3.80	-	3.70	-	V	
V _{OL}	LOW-level output voltage	V _I = V _{IH} or V _{IL}								
		I _O = 50 μA; V _{CC} = 2.0 V	-	0	0.1	-	0.1	-	0.1	V
		I _O = 50 μA; V _{CC} = 3.0 V	-	0	0.1	-	0.1	-	0.1	V
		I _O = 50 μA; V _{CC} = 4.5 V	-	0	0.1	-	0.1	-	0.1	V
		I _O = 4.0 mA; V _{CC} = 3.0 V	-	-	0.36	-	0.44	-	0.55	V
	I _O = 8.0 mA; V _{CC} = 4.5 V	-	-	0.36	-	0.44	-	0.55	V	
I _I	input leakage current	V _I = 5.5 V or GND; V _{CC} = 0 V to 5.5 V	-	-	0.1	-	1.0	-	2.0	μA
I _{CC}	supply current	V _I = V _{CC} or GND; I _O = 0 A; V _{CC} = 5.5 V	-	-	4.0	-	40	-	80	μA
C _I	input capacitance	V _I = V _{CC} or GND	-	3	10	-	10	-	10	pF
C _O	output capacitance		-	4	-	-	-	-	-	pF
74AHCT259-Q100										
V _{IH}	HIGH-level input voltage	V _{CC} = 4.5 V to 5.5 V	2.0	-	-	2.0	-	2.0	-	V
V _{IL}	LOW-level input voltage	V _{CC} = 4.5 V to 5.5 V	-	-	0.8	-	0.8	-	0.8	V
V _{OH}	HIGH-level output voltage	V _I = V _{IH} or V _{IL} ; V _{CC} = 4.5 V								
		I _O = -50 μA	4.4	4.5	-	4.4	-	4.4	-	V
		I _O = -8.0 mA	3.94	-	-	3.80	-	3.70	-	V
V _{OL}	LOW-level output voltage	V _I = V _{IH} or V _{IL} ; V _{CC} = 4.5 V								
		I _O = 50 μA	-	0	0.1	-	0.1	-	0.1	V
		I _O = 8.0 mA	-	-	0.36	-	0.44	-	0.55	V

Table 7. Static characteristics ...continued

At recommended operating conditions; voltages are referenced to GND (ground = 0 V).

Symbol	Parameter	Conditions	25 °C			-40 °C to +85 °C		-40 °C to +125 °C		Unit
			Min	Typ	Max	Min	Max	Min	Max	
I _I	input leakage current	V _I = 5.5 V or GND; V _{CC} = 0 V to 5.5 V	-	-	0.1	-	1.0	-	2.0	μA
I _{CC}	supply current	V _I = V _{CC} or GND; I _O = 0 A; V _{CC} = 5.5 V	-	-	4.0	-	40	-	80	μA
ΔI _{CC}	additional supply current	per input pin; V _I = V _{CC} - 2.1 V; other pins at V _{CC} or GND; I _O = 0 A; V _{CC} = 4.5 V to 5.5 V	-	-	1.35	-	1.5	-	1.5	mA
C _I	input capacitance	V _I = V _{CC} or GND	-	3	10	-	10	-	10	pF
C _O	output capacitance		-	4	-	-	-	-	-	pF

10. Dynamic characteristics

Table 8. Dynamic characteristics

Voltages are referenced to GND (ground = 0 V); for test circuit, see [Figure 11](#).

Symbol	Parameter	Conditions	25 °C			-40 °C to +85 °C		-40 °C to +125 °C		Unit	
			Min	Typ ^[1]	Max	Min	Max	Min	Max		
74AHC259-Q100											
t _{pd}	propagation delay	D to Qn; see Figure 5	[2]								
		V _{CC} = 3.0 V to 3.6 V									
		C _L = 15 pF	-	5.8	11.5	1.0	13.5	1.0	15.0	ns	
		C _L = 50 pF	-	7.3	14.5	1.0	17.0	1.0	18.5	ns	
		V _{CC} = 4.5 V to 5.5 V									
		C _L = 15 pF	-	4.1	7.5	1.0	9.0	1.0	10.0	ns	
		C _L = 50 pF	-	5.3	9.5	1.0	11.0	1.0	12.0	ns	
		An to Qn; see Figure 6	[2]								
		V _{CC} = 3.0 V to 3.6 V									
		C _L = 15 pF	-	7.5	14.5	1.0	17.0	1.0	18.5	ns	
		C _L = 50 pF	-	9.1	18.0	1.0	21.0	1.0	23.0	ns	
		V _{CC} = 4.5 V to 5.5 V									
		C _L = 15 pF	-	5.3	9.5	1.0	11.5	1.0	12.5	ns	
		C _L = 50 pF	-	6.5	11.5	1.0	13.5	1.0	15.0	ns	
LE to Qn; see Figure 7			[2]								
			V _{CC} = 3.0 V to 3.6 V								
			C _L = 15 pF	-	6.2	12.0	1.0	14.0	1.0	15.2	ns
			C _L = 50 pF	-	7.7	15.5	1.0	17.5	1.0	19.0	ns
			V _{CC} = 4.5 V to 5.5 V								
			C _L = 15 pF	-	4.3	8.0	1.0	9.5	1.0	10.5	ns
C _L = 50 pF	-	5.5	10.0	1.0	11.5	1.0	12.5	ns			

Table 8. Dynamic characteristics ...continued
 Voltages are referenced to GND (ground = 0 V); for test circuit, see [Figure 11](#).

Symbol	Parameter	Conditions	25 °C			-40 °C to +85 °C		-40 °C to +125 °C		Unit
			Min	Typ ^[1]	Max	Min	Max	Min	Max	
t _{pd}	propagation delay	\overline{MR} to Qn; see Figure 8 ^[3]								
		V _{CC} = 3.0 V to 3.6 V								
		C _L = 15 pF	-	5.4	10.5	1.0	12.5	1.0	13.5	ns
		C _L = 50 pF	-	7.0	13.5	1.0	15.5	1.0	17.0	ns
		V _{CC} = 4.5 V to 5.5 V								
t _w	pulse width	\overline{LE} HIGH or LOW; see Figure 7								
		V _{CC} = 3.0 V to 3.6 V	5.0	-	-	5.0	-	5.0	-	ns
		V _{CC} = 4.5 V to 5.5 V	5.0	-	-	5.0	-	5.0	-	ns
		\overline{MR} LOW; see Figure 8								
		V _{CC} = 3.0 V to 3.6 V	5.0	-	-	5.0	-	5.0	-	ns
t _{su}	set-up time	D, An to \overline{LE} ; see Figure 9 and Figure 10								
		V _{CC} = 3.0 V to 3.6 V	4.0	-	-	4.0	-	4.0	-	ns
		V _{CC} = 4.5 V to 5.5 V	4.0	-	-	4.0	-	4.0	-	ns
t _h	hold time	D, An to \overline{LE} ; see Figure 9 and Figure 10								
		V _{CC} = 3.0 V to 3.6 V	1.0	-	-	1.0	-	1.0	-	ns
		V _{CC} = 4.5 V to 5.5 V	1.0	-	-	1.0	-	1.0	-	ns
C _{PD}	power dissipation capacitance	f _i = 1 MHz; V _I = GND to V _{CC} ^[4]	-	13	-	-	-	-	-	pF

74AHCT259-Q100; V_{CC} = 4.5 V to 5.5 V

t _{pd}	propagation delay	D to Qn; see Figure 5 ^[2]								
		C _L = 15 pF	-	4.1	7.5	1.0	9.0	1.0	10.0	ns
		C _L = 50 pF	-	5.4	9.5	1.0	11.0	1.0	12.0	ns
		An to Qn; see Figure 6 ^[2]								
		C _L = 15 pF	-	5.5	9.5	1.0	11.5	1.0	12.5	ns
		C _L = 50 pF	-	6.6	12.0	1.0	14.0	1.0	15.5	ns
		\overline{LE} to Qn; see Figure 7 ^[2]								
		C _L = 15 pF	-	4.3	8.0	1.0	9.5	1.0	10.4	ns
		C _L = 50 pF	-	5.5	10.0	1.0	12.0	1.0	13.0	ns
		\overline{MR} to Qn; see Figure 8 ^[3]								
		C _L = 15 pF	-	3.9	7.0	1.0	8.5	1.0	9.5	ns
		C _L = 50 pF	-	5.1	9.0	1.0	10.5	1.0	11.5	ns
		t _w	pulse width	\overline{LE} HIGH or LOW; see Figure 7	5.0	-	-	5.0	-	5.0
\overline{MR} LOW; see Figure 8	5.0			-	-	5.0	-	5.0	-	ns

Table 8. Dynamic characteristics ...continued
 Voltages are referenced to GND (ground = 0 V); for test circuit, see [Figure 11](#).

Symbol	Parameter	Conditions	25 °C			-40 °C to +85 °C		-40 °C to +125 °C		Unit
			Min	Typ ^[1]	Max	Min	Max	Min	Max	
t _{su}	set-up time	D, An to \overline{LE} ; see Figure 9 and Figure 10	4.0	-	-	4.0	-	4.0	-	ns
t _h	hold time	D, An to \overline{LE} ; see Figure 9 and Figure 10	1.0	-	-	1.0	-	1.0	-	ns
C _{PD}	power dissipation capacitance	f _i = 1 MHz; V _I = GND to V _{CC} ^[4]	-	17	-	-	-	-	-	pF

- [1] Typical values are measured at nominal supply voltage (V_{CC} = 3.3 V and V_{CC} = 5.0 V).
- [2] t_{pd} is the same as t_{PLH} and t_{PHL}.
- [3] t_{pd} is the same as t_{PHL} only.
- [4] C_{PD} is used to determine the dynamic power dissipation (P_D in μW).
 $P_D = C_{PD} \times V_{CC}^2 \times f_i \times N + \Sigma(C_L \times V_{CC}^2 \times f_o)$ where:
 f_i = input frequency in MHz;
 f_o = output frequency in MHz;
 C_L = output load capacitance in pF;
 V_{CC} = supply voltage in V;
 N = number of inputs switching;
 $\Sigma(C_L \times V_{CC}^2 \times f_o)$ = sum of the outputs.

11. Waveforms

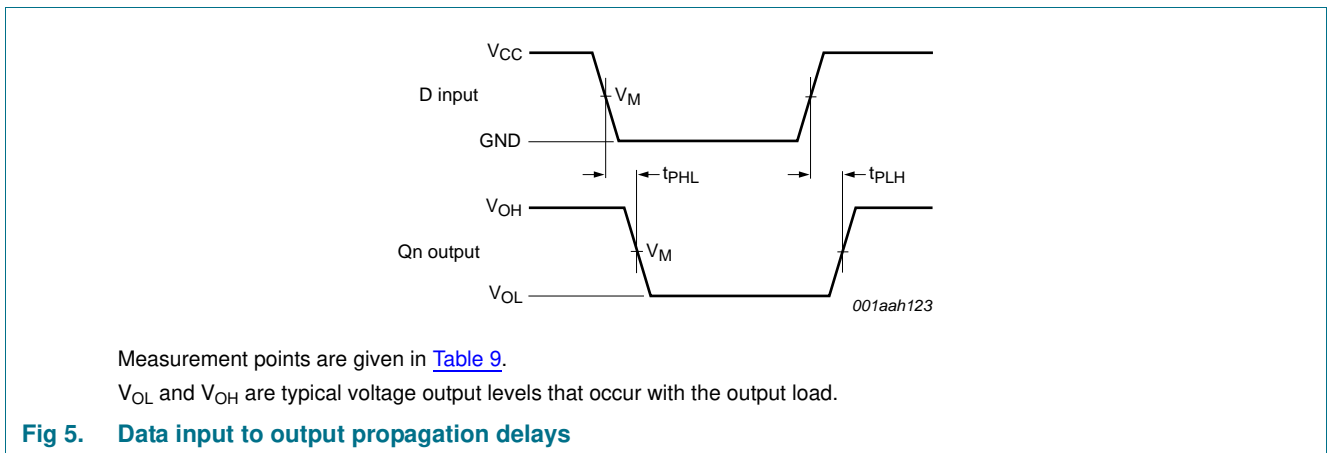

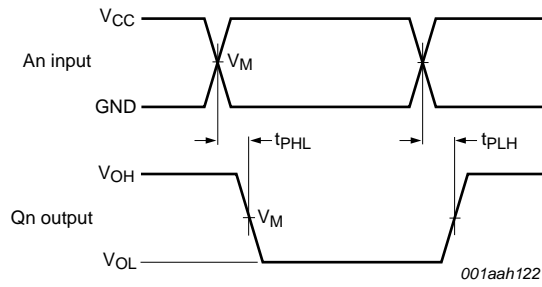

Measurement points are given in [Table 9](#).
 V_{OL} and V_{OH} are typical voltage output levels that occur with the output load.

Fig 6. Address input to output propagation delays

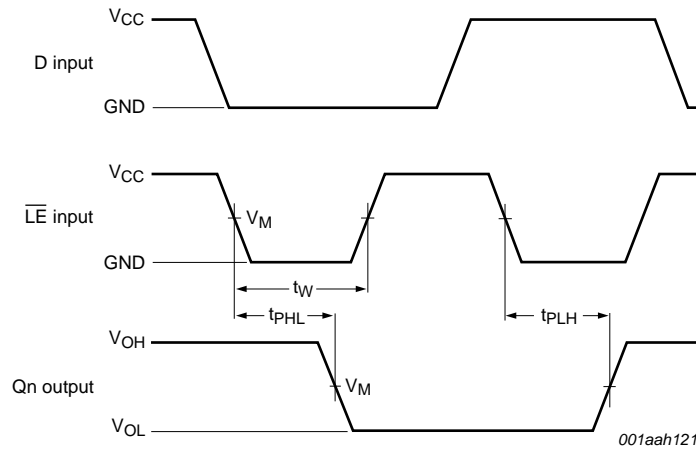

Measurement points are given in [Table 9](#).
 V_{OL} and V_{OH} are typical voltage output levels that occur with the output load.

Fig 7. Enable input to output propagation delays and pulse width

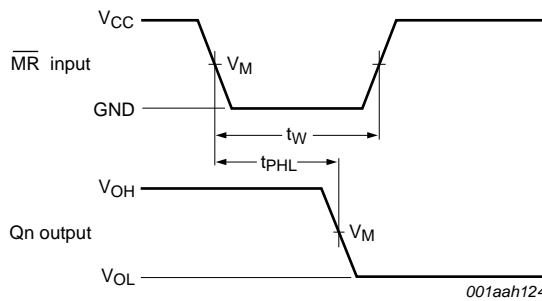

Measurement points are given in [Table 9](#).
 V_{OL} and V_{OH} are typical voltage output levels that occur with the output load.

Fig 8. Conditional reset input to output propagation delays

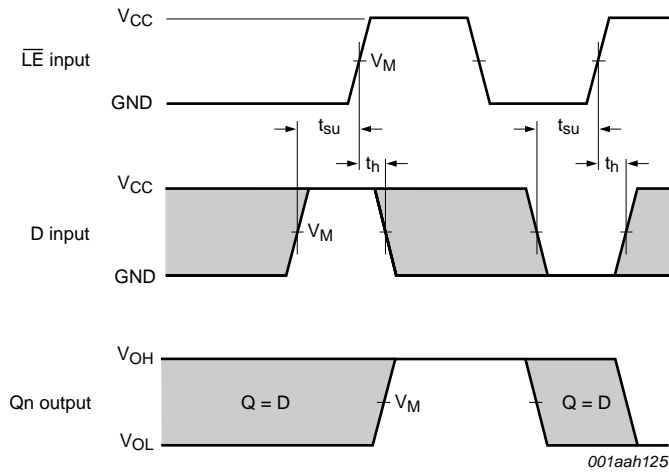

Measurement points are given in [Table 9](#).
 The shaded areas indicate when the input is permitted to change for predictable output performance.
 V_{OL} and V_{OH} are typical voltage output levels that occur with the output load.

Fig 9. Data input to latch enable input set-up and hold times

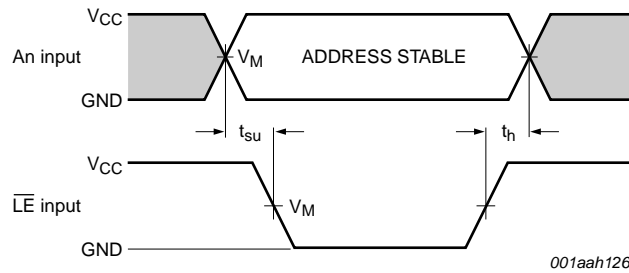

Measurement points are given in [Table 9](#).
 The shaded areas indicate when the input is permitted to change for predictable output performance.
 V_{OL} and V_{OH} are typical voltage output levels that occur with the output load.

Fig 10. Address input to latch enable input set-up and hold times

Table 9. Measurement points

Type	Input	Output
	V_M	V_M
74AHC259-Q100	$0.5 \times V_{CC}$	$0.5 \times V_{CC}$
74AHCT259-Q100	1.5 V	$0.5 \times V_{CC}$

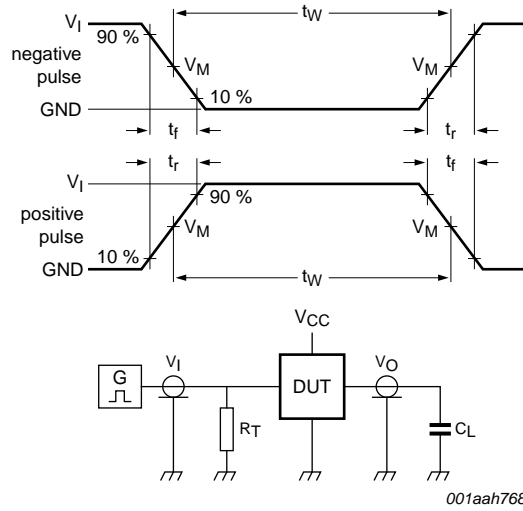

001aah768

Test data is given in [Table 10](#).

Definitions test circuit:

R_T = termination resistance should be equal to output impedance Z_o of the pulse generator.

C_L = load capacitance including jig and probe capacitance.

Fig 11. Load circuitry for measuring switching times

Table 10. Test data

Type	Input		Load	Test
	V_I	t_r, t_f		
74AHC259-Q100	V_{CC}	≤ 3.0 ns	15 pF, 50 pF	t_{PLH}, t_{PHL}
74AHCT259-Q100	3.0 V	≤ 3.0 ns	15 pF, 50 pF	t_{PLH}, t_{PHL}

12. Package outline

SO16: plastic small outline package; 16 leads; body width 3.9 mm

SOT109-1

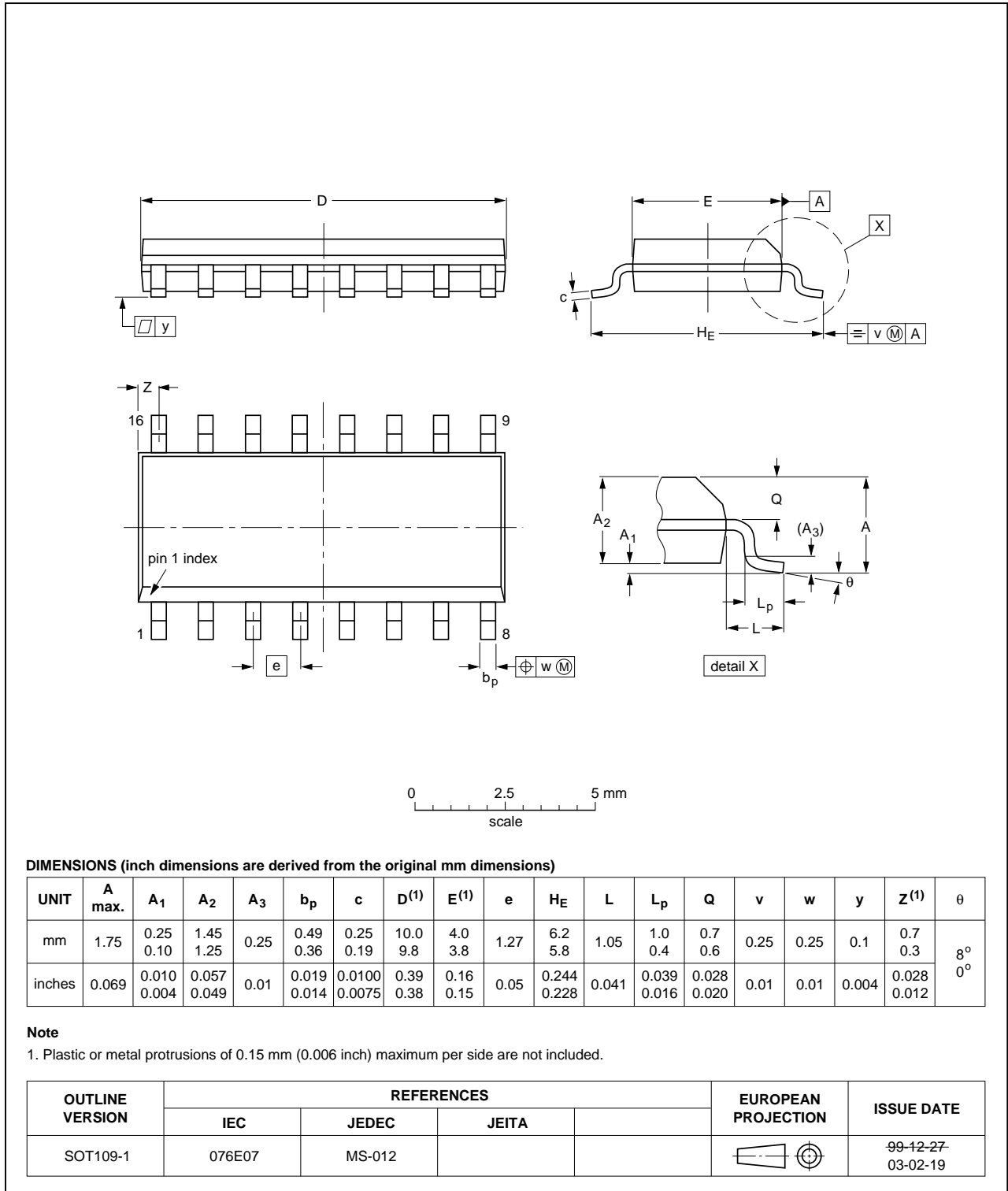

Fig 12. Package outline SOT109-1 (SO16)

TSSOP16: plastic thin shrink small outline package; 16 leads; body width 4.4 mm

SOT403-1

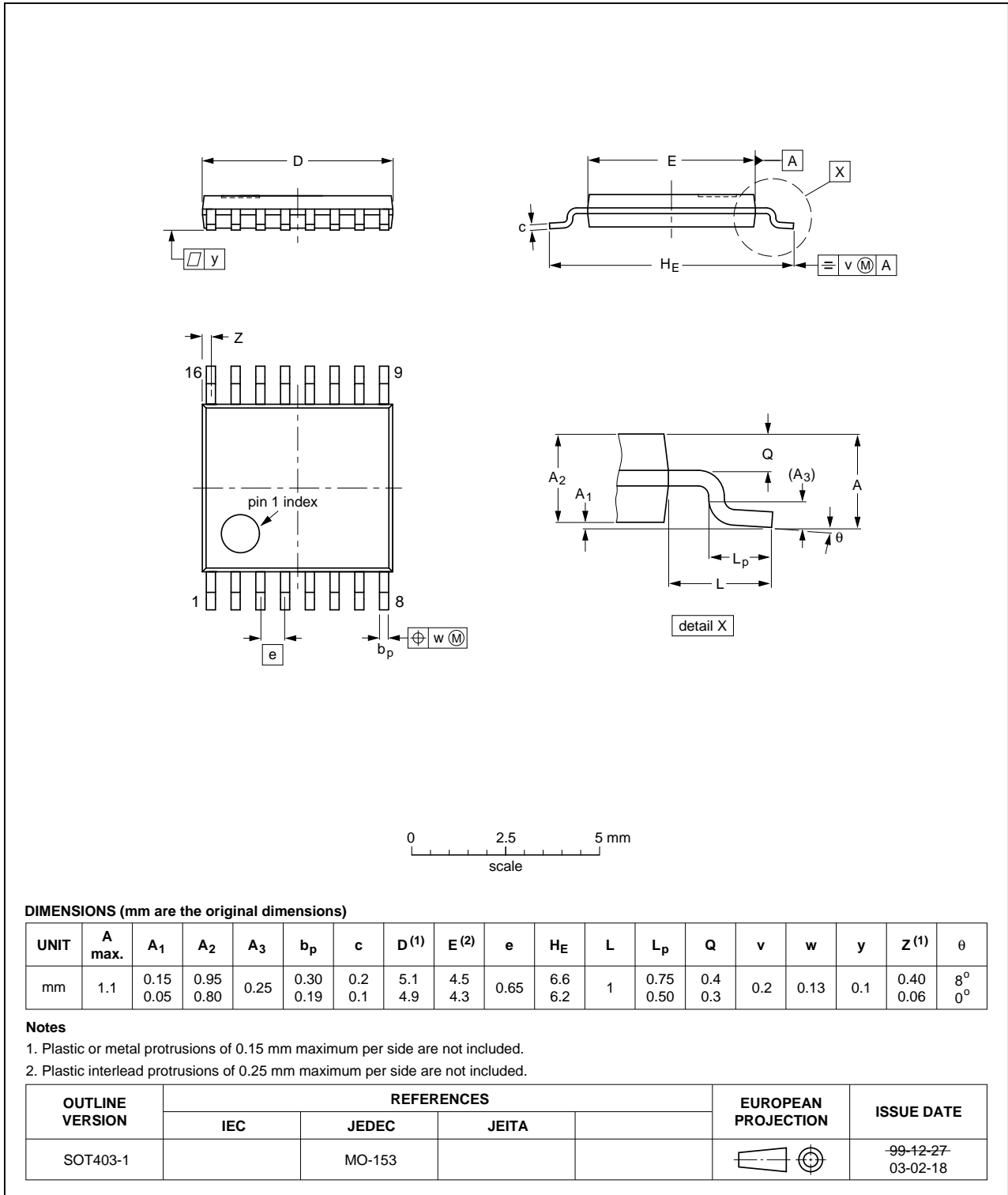

Fig 13. Package outline SOT403-1 (TSSOP16)

13. Abbreviations

Table 11. Abbreviations

Acronym	Description
CDM	Charged Device Model
CMOS	Complementary Metal-Oxide Semiconductor
ESD	ElectroStatic Discharge
HBM	Human Body Model
MM	Machine Model
MIL	Military
TTL	Transistor-Transistor Logic

14. Revision history

Table 12. Revision history

Document ID	Release date	Data sheet status	Change notice	Supersedes
74AHC_AHCT259_Q100 v.1	20130722	Product data sheet	-	-

15. Legal information

15.1 Data sheet status

Document status ^{[1][2]}	Product status ^[3]	Definition
Objective [short] data sheet	Development	This document contains data from the objective specification for product development.
Preliminary [short] data sheet	Qualification	This document contains data from the preliminary specification.
Product [short] data sheet	Production	This document contains the product specification.

[1] Please consult the most recently issued document before initiating or completing a design.

[2] The term 'short data sheet' is explained in section "Definitions".

[3] The product status of device(s) described in this document may have changed since this document was published and may differ in case of multiple devices. The latest product status information is available on the Internet at URL <http://www.nxp.com>.

15.2 Definitions

Draft — The document is a draft version only. The content is still under internal review and subject to formal approval, which may result in modifications or additions. NXP Semiconductors does not give any representations or warranties as to the accuracy or completeness of information included herein and shall have no liability for the consequences of use of such information.

Short data sheet — A short data sheet is an extract from a full data sheet with the same product type number(s) and title. A short data sheet is intended for quick reference only and should not be relied upon to contain detailed and full information. For detailed and full information see the relevant full data sheet, which is available on request via the local NXP Semiconductors sales office. In case of any inconsistency or conflict with the short data sheet, the full data sheet shall prevail.

Product specification — The information and data provided in a Product data sheet shall define the specification of the product as agreed between NXP Semiconductors and its customer, unless NXP Semiconductors and customer have explicitly agreed otherwise in writing. In no event however, shall an agreement be valid in which the NXP Semiconductors product is deemed to offer functions and qualities beyond those described in the Product data sheet.

15.3 Disclaimers

Limited warranty and liability — Information in this document is believed to be accurate and reliable. However, NXP Semiconductors does not give any representations or warranties, expressed or implied, as to the accuracy or completeness of such information and shall have no liability for the consequences of use of such information. NXP Semiconductors takes no responsibility for the content in this document if provided by an information source outside of NXP Semiconductors.

In no event shall NXP Semiconductors be liable for any indirect, incidental, punitive, special or consequential damages (including - without limitation - lost profits, lost savings, business interruption, costs related to the removal or replacement of any products or rework charges) whether or not such damages are based on tort (including negligence), warranty, breach of contract or any other legal theory.

Notwithstanding any damages that customer might incur for any reason whatsoever, NXP Semiconductors' aggregate and cumulative liability towards customer for the products described herein shall be limited in accordance with the *Terms and conditions of commercial sale* of NXP Semiconductors.

Right to make changes — NXP Semiconductors reserves the right to make changes to information published in this document, including without limitation specifications and product descriptions, at any time and without notice. This document supersedes and replaces all information supplied prior to the publication hereof.

Suitability for use in automotive applications — This NXP Semiconductors product has been qualified for use in automotive applications. Unless otherwise agreed in writing, the product is not designed, authorized or warranted to be suitable for use in life support, life-critical or safety-critical systems or equipment, nor in applications where failure or malfunction of an NXP Semiconductors product can reasonably be expected to result in personal injury, death or severe property or environmental damage. NXP Semiconductors and its suppliers accept no liability for inclusion and/or use of NXP Semiconductors products in such equipment or applications and therefore such inclusion and/or use is at the customer's own risk.

Applications — Applications that are described herein for any of these products are for illustrative purposes only. NXP Semiconductors makes no representation or warranty that such applications will be suitable for the specified use without further testing or modification.

Customers are responsible for the design and operation of their applications and products using NXP Semiconductors products, and NXP Semiconductors accepts no liability for any assistance with applications or customer product design. It is customer's sole responsibility to determine whether the NXP Semiconductors product is suitable and fit for the customer's applications and products planned, as well as for the planned application and use of customer's third party customer(s). Customers should provide appropriate design and operating safeguards to minimize the risks associated with their applications and products.

NXP Semiconductors does not accept any liability related to any default, damage, costs or problem which is based on any weakness or default in the customer's applications or products, or the application or use by customer's third party customer(s). Customer is responsible for doing all necessary testing for the customer's applications and products using NXP Semiconductors products in order to avoid a default of the applications and the products or of the application or use by customer's third party customer(s). NXP does not accept any liability in this respect.

Limiting values — Stress above one or more limiting values (as defined in the Absolute Maximum Ratings System of IEC 60134) will cause permanent damage to the device. Limiting values are stress ratings only and (proper) operation of the device at these or any other conditions above those given in the Recommended operating conditions section (if present) or the Characteristics sections of this document is not warranted. Constant or repeated exposure to limiting values will permanently and irreversibly affect the quality and reliability of the device.

Terms and conditions of commercial sale — NXP Semiconductors products are sold subject to the general terms and conditions of commercial sale, as published at <http://www.nxp.com/profile/terms>, unless otherwise agreed in a valid written individual agreement. In case an individual agreement is concluded only the terms and conditions of the respective agreement shall apply. NXP Semiconductors hereby expressly objects to applying the customer's general terms and conditions with regard to the purchase of NXP Semiconductors products by customer.

No offer to sell or license — Nothing in this document may be interpreted or construed as an offer to sell products that is open for acceptance or the grant, conveyance or implication of any license under any copyrights, patents or other industrial or intellectual property rights.

Export control — This document as well as the item(s) described herein may be subject to export control regulations. Export might require a prior authorization from competent authorities.

Translations — A non-English (translated) version of a document is for reference only. The English version shall prevail in case of any discrepancy between the translated and English versions.

15.4 Trademarks

Notice: All referenced brands, product names, service names and trademarks are the property of their respective owners.

16. Contact information

For more information, please visit: <http://www.nxp.com>

For sales office addresses, please send an email to: salesaddresses@nxp.com

17. Contents

1	General description	1
2	Features and benefits	1
3	Ordering information	2
4	Functional diagram	3
5	Pinning information	4
5.1	Pinning	4
5.2	Pin description	4
6	Functional description	5
7	Limiting values	6
8	Recommended operating conditions	6
9	Static characteristics	7
10	Dynamic characteristics	8
11	Waveforms	10
12	Package outline	14
13	Abbreviations	16
14	Revision history	16
15	Legal information	17
15.1	Data sheet status	17
15.2	Definitions	17
15.3	Disclaimers	17
15.4	Trademarks	18
16	Contact information	18
17	Contents	19

Please be aware that important notices concerning this document and the product(s) described herein, have been included in section 'Legal information'.

© NXP B.V. 2013.

All rights reserved.

For more information, please visit: <http://www.nxp.com>

For sales office addresses, please send an email to: salesaddresses@nxp.com

Date of release: 22 July 2013

Document identifier: 74AHC_AHCT259_Q100