

S1D13522 EPD Controller

February 21 2013

EPSON's S1D13522 controller builds on the success of the S1D13521 providing high performance, low system cost solutions for E Ink EPDs (Electronic Paper Displays).

The S1D13522 includes 2M bytes of stacked memory and features that greatly reduce the CPU overhead for EPD applications. Allowing multi-regional and concurrent display updates, the S1D13522 adds interface support for direct Touch/Pen drawing. Picture-in-Picture, Rotation, Transparency, and Hardware Cursor functions further increase the flexibility in delivering the optimal display experience.

The Advanced Sequencer Engine, Power Management, I2C Thermal Sensor, and optional Serial Flash Memory support make a variety of implementations possible. The S1D13522 is the ideal choice for new EPD designs and design upgrades.

■ Features

- Targeted for display resolutions up to 1200x825
- Smooth screen updates
- Multi-Regional updates for smooth drawing
- Rotation support for Host Writes
- Low Host overhead
- 16-bit Indirect or Serial Host Support
- I²C Thermal Sensor provides temperature support for automatic temperature compensation.
- Optional Serial Flash Memory with auto boot display support and customizable boot screen
- Programmable Power Management for panel power saving
- 2M bytes of stacked memory
- SPI master supporting 2 slave devices
- Advanced Sequencer Engine w/ ALU
- Picture-in-Picture and Cursor functions with separate buffers
- Supports Direct Touch/Pen drawing
- Internal Programmable PLL
- Single MHz Clock Input
- Software Power Save Mode
- General Purpose IO Pins available
- Package: PFBGA (0.8mm and 0.5mm ball pitch)

■ System Block Diagram

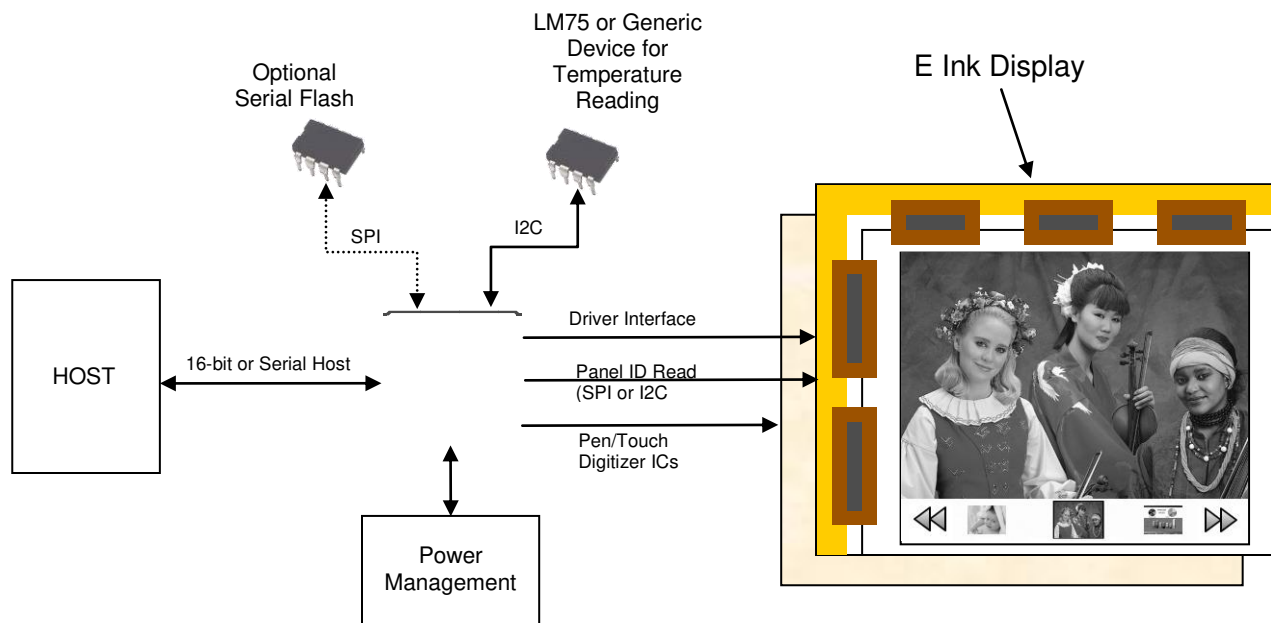

■ Description

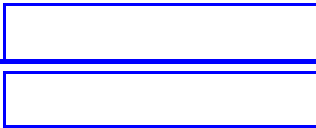

Display Support

- Compatible with E Ink Active Matrix Panels
- Compatible with LG Display – Gate In Panel (GIP)
- Up to 1200x825 @ 50Hz
- Up to 4-bit grayscale waveforms (16 grey-shades)
- Auto Waveform Management Version 2
- Panel Border Support
- Waveform format: E Ink's

Stacked Memory

- 2M bytes of Stacked memory
- Host write rotation: 90°, 180°, or 270°
- Host writes can use packed mode for high-speed transfers
- Host writes with transparency for non-rectangular images
- New image data can be loaded to the image buffer while display updates are in progress

Host Support

- Indirect Intel 80 16-bit or Serial Host
- Simplified command style access
- DMA compatible memory bus style host interface
- Advanced Sequencer Engine w/ALU performs pre-programmed series of commands from Host

Display Features

- Picture-in-Picture (PIP) window with separate image buffer and transparency function
- Hardware Cursor support

Serial Flash Memory Waveform Read Support

- Optional SPI Flash memory for auto boot display support and customizable boot screen
- High Speed SPI Mode

Power Management Support

- 4-pin power sequencing control with auto power on/off for update operations

I²C Thermal Sensor Temperature Reading Support

- Supports LM75 digital temperature sensor and compatible devices
- Generic I2C device support

Clock Source

- Internal Programmable PLL
- Single MHz clock input (CLKI/Crystal)

Miscellaneous

- SPI master supporting 2 slave devices (i.e. Serial Flash, Panel ID retrieval, etc.)
- Supports Pen/Touch Digitizer ICs (SPI or UART)
- Software Power Save Modes
- Low and ultra-low power modes
- General Purpose Input/Output pins
- Each GPIO pin can be configured for edge detect interrupt
- Package:
 - PFBGA 144-pin (10mm x 10mm, 0.8mm pitch)
 - PFBGA 144-pin (7mm x 7mm, 0.5mm pitch)
 - Core Voltage: 1.8V
 - IO Voltage: 1.65V ~ 3.6V

n/a

For technical and ordering information for the E Ink AM350 Broadsheet Prototype Kit, contact E Ink at www.eink.com/kits/.

For technical and ordering information for the S1D13522 EPD Controller, contact your EPSON sales representative.

Japan

Seiko Epson Corporation
IC International Sales Group
421-8, Hino, Hino-shi
Tokyo 191-8501, Japan
Tel: +81-42-587-5814
Fax: +81-42-587-5117

North America

Epson Electronics America, Inc.
2580 Orchard Parkway
San Jose, CA 95131, USA
Tel: +1-800-228-3964
Fax: +1-408-922-0238

China

Epson (China) Co., Ltd.
7F, Jinbao Bldg.
No. 89 Jinbao St.
Dongcheng District
Beijing 100005, China
Tel: +86-10-6410-6555
Fax: +86-10-6410-7320

Taiwan

Epson Taiwan Technology & Trading Ltd.
14F, No. 7
Song Ren Road
Taipei 110, Taiwan
Tel: +886-2-8786-6688
Fax: +886-2-8786-6660

Hong Kong

Epson Hong Kong Ltd.
20/F, Harbour Centre
25 Harbour Road
Wanchai, Hong Kong
Tel: +852-2585-4600
Fax: +852-2827-4346

Europe

Epson Europe Electronics GmbH
Riesstrasse 15
80992 Munich, Germany
Tel: +49-89-14005-0
Fax: +49-89-14005-110

Singapore

Epson Singapore Pte., Ltd.
1 HarbourFront Place
#03-02 HarbourFront Tower One
Singapore 098633
Tel: +65-6586-5500
Fax: +65-6271-3182

Korea

Seiko Epson Corp.
Korea Office
50F, LKI 63 Bldg.
60 Yoido-dong, Youngdeungpo-Ku,
Seoul, 150-763, Korea
Tel: +82-2-784-6027
Fax: +82-2-767-3677

© SEIKO EPSON CORPORATION 2009-2013. All rights reserved.
Information in this document is subject to change without notice. You may download and use this document, but only for your own use in evaluating Seiko Epson/EPSON products. You may not modify the document. Epson Research and Development, Inc. disclaims any representation that the contents of this document are accurate or current. The Programs/Technologies described in this document may contain material protected under U.S. and/or International Patent laws.
EPSON is a registered trademark of Seiko Epson Corporation. All other trademarks are the property of their respective owners.

Epson semiconductor website http://www.epson.jp/device/semicon_e/