

- > precision pliers for ultra fine cutting work in electronics and fine mechanics
- > ground, very sharp cutting edges without bevel for flush cutting
- > precision shaped tips cut wires resting on a board from 1/64" (0.2 mm) dia.
- > joint with stainless steel rivet
- > extremely smooth movement for minimum operator fatigue
- > includes opening spring for easy repetitive work

78 03 125 / 78 23 125

Cutting edge hardness approx. 54 HRC; INOX – stainless steel

78 13 125

With lead catcher – no uncontrolled loss of cut wire ends; cutting edge hardness approx. 54 HRC; INOX – stainless steel

78 31 125

With narrow head; cutting edge hardness approx. 60 HRC; special tool steel, burnished

78 41 125

With lead catcher – no uncontrolled loss of cut wire ends; with narrow head; cutting edge hardness approx. 60 HRC; special tool steel, burnished

78 61 125

Suitable for cutting glass fiber cables (fiber optics); cutting edge hardness approx. 64 HRC; special tool steel, multi stage oil-hardened

78 71 125

With lead catcher – no uncontrolled loss of cut wire ends; cutting edge hardness approx. 64 HRC; special tool steel, burnished

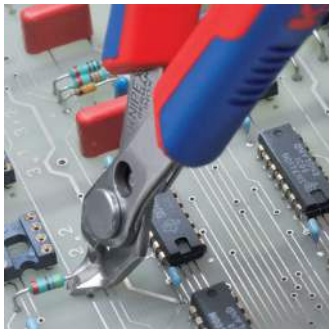

78 03 125
✂️  



78 13 125
✂️   



78 23 125
✂️ $\angle 60^\circ$  



78 31 125
✂️  



78 41 125
✂️   

Models for hard wire

78 81 125

Precision ground cutting edges with very small bevel suitable for hard wire; cutting edge hardness approx. 64 HRC; special tool steel, burnished

78 91 125

Precision ground cutting edges with very small bevel suitable for hard wire; with lead catcher – no uncontrolled loss of cut wire ends; cutting edge hardness approx. 64 HRC; special tool steel, burnished

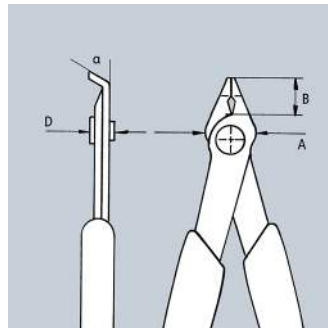
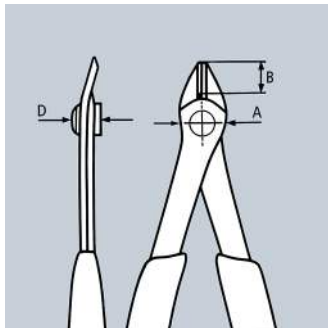

78 61 125



78 71 125



78 81 125



78 91 125

Product Number	Packaging	↔ Inch mm	Pliers	Head	Handles	Cutting capacities			Dimensions			⚖️ lbs
						☉ Ø Inch Ø mm	☉ Ø Inch Ø mm	☉ Ø Inch Ø mm	A Inch mm	B Inch mm	D Inch mm	
78 03 125		5 125		polished	multi-component grips	1/64 - 1/16 0.2 - 1.6	3/64 1.0	-	17/32 13.5	23/64 9.0	19/64 7.5	0.13
78 13 125		5 125		polished	multi-component grips	1/64 - 1/16 0.2 - 1.6	3/64 1.0	-	17/32 13.5	23/64 9.0	19/64 7.5	0.14
78 23 125	X	5 125		polished	multi-component grips	1/64 - 3/64 0.2 - 1.0	1/64 0.2	-	17/32 13.5	7/32 5.5	19/64 7.5	0.12
78 31 125		5 125		burnished	multi-component grips	1/64 - 3/64 0.2 - 1.0	-	-	17/32 13.5	23/64 9.0	19/64 7.5	0.13
78 41 125		5 125		burnished	multi-component grips	1/64 - 3/64 0.2 - 1.0	-	-	17/32 13.5	23/64 9.0	19/64 7.5	0.14
78 61 125	X	5 125		burnished	multi-component grips	1/64 - 1/16 0.2 - 1.6	3/64 1.2	-	17/32 13.5	23/64 9.0	19/64 7.5	0.13
78 71 125		5 125		burnished	multi-component grips	1/64 - 1/16 0.2 - 1.6	3/64 1.2	-	17/32 13.5	23/64 9.0	19/64 7.5	0.14
78 81 125		5 125		burnished	multi-component grips	5/64 - 1/16 1.2 - 1.6	3/64 1.2	1/64 0.2	17/32 13.5	23/64 9.0	19/64 7.5	0.14
78 91 125		5 125		burnished	multi-component grips	5/64 - 1/16 1.2 - 1.6	3/64 1.2	1/64 0.2	17/32 13.5	23/64 9.0	19/64 7.5	0.14