

USB2.0 High Speed (HS) On-the-Go (OTG) Dual Role Controller

FEATURES

- **USB 2.0 HS OTG Dual Role Controller Core**
 - Act as a USB 2.0 HS Peripheral
 - Act as a USB 2.0 HS Embedded Host Controller
 - Act as a USB 2.0 HS OTG Device
 - Supports Session Request Protocol (SRP)
 - Supports Host Negotiation Protocol (HNP)
- **Integrated USB 2.0 OTG PHY**
- **NOR FLASH - Like External Host Interface**
- **Configurable for up to 15 transmit endpoints and up to 15 receive endpoints**
 - 16 kilobyte RAM for USB endpoint FIFO shared by USB IN/OUT endpoints
 - Configurable FIFOs, including the option of dynamic FIFO sizing
 - Support for external DMA access to FIFOs
- **Power Management Module**
 - Ultra low power Idle mode for battery conscious applications
 - Support for External Charge Pump
- **TUSB6010BZQE/TUSB6010BIZQE are RoHS compliant.**
- **80 Terminal BGA Microstar Junior Package**

DESCRIPTION

The TUSB6010B is a USB 2.0 HS Dual Role USB Controller designed for seamless interface to an external Host processor through the NOR FLASH-like interface. The TUSB6010B can be used to enable the processor to implement any one of three general types of USB devices. It can be implemented as a USB high-speed peripheral (or target), as a USB high-speed, single-port, embedded host controller, or as a USB high-speed OTG device. Software on the application processor will be required to implement the chosen type of USB device.

The NOR FLASH-like interface is a multiplexed, 16-bit interface with support for burst and single read/write access. It can operate in both synchronous and asynchronous modes.

The Power Management Module provides external USB OTG Charge Pump control through the power control/status interface. The Power Management Module provides a seamless interface to the TPS65030 Power Management IC for USB-OTG.

The device also has eight user configurable general purpose I/O interface pins. The GPIO can be configured as an interrupt or wakeup source. Some GPIO have secondary NOR-flash DMA Request functionality.

The device is fully compliant with the Universal Serial Bus Specification Rev. 2.0 and On-The-Go Supplement to the USB Specification Rev. 1.3.

The ESD protection level is 2KV HBM (JESD22-A114D), 500V CDM (JESD22-C101C).

NOTE:

This product is intended for high-volume handset applications only. Contact support@ti.com for more information.

PRODUCT PREVIEW



Please be aware that an important notice concerning availability, standard warranty, and use in critical applications of Texas Instruments semiconductor products and disclaimers thereto appears at the end of this data sheet.

Device Power States

TUSB6010 has three device states typically entered under normal operation:

- RESET
- IDLE
- NORMAL (ACTIVE)

RESET State

The device shall be in RESET state when the RSTn input signal is driven low. In the RESET state:

- All output ports are tri-stated or initialized to inactive state
- All bi-directional ports are configured as Inputs
- All registers are set to their reset value
- PHY Macro is enabled and its reference clock output is active

Device always enters RESET state asynchronously, but exit the state synchronously. System reset de-assertion is always synchronized with active system clock. Upon asserted system reset, device requires active system clock to exit RESET state.

IDLE State

Device enters the IDLE state when External Host sets DevIdle bit in the Device Power Management register. In the IDLE State, the device power consumption should not exceed 100 μ A, including companion Power Management device (TPS65030).

In IDLE state:

- All output signals are driven to state with minimum IO current leakage (pull-up/pull-downs are controllable through Pull-up/Pull-Down Control registers)
- All controllable bi-directional pins are placed into minimum current leakage state
- All registers and memories retain the content and any read/write registers access is disabled
- All clock sources are disabled
- PHY Macro is suspended:
 - Low power V_{BUS} sense comparator is enabled and all regular V_{BUS} comparators are disabled to minimize current consumption.
 - ID Detection circuitry is enabled
 - Remaining analog circuitry is disabled

Device stays in the IDLE state until a valid wake-up event occurs and transitions into the NORMAL (ACTIVE) State. If system reset is asserted (RSTn) device transitions to RESET state.

NORMAL (ACTIVE) State

A transition to the Normal state is required for normal device operation. All circuitry is enabled. In the Normal state:

- All I/O are enabled.
- All registers and memories are accessible
- Clock sources are enabled
- PHY Macro is enabled
 - Session End V_{BUS} detect circuitry shall be enabled
 - V_{BUS} detection circuitry shall be enabled
 - ID Detection circuitry shall be enabled

Application Diagram

Typical USB application utilizing the TPS65030 Power Management Device and TUSB6010. External Host connects to the NOR Interface and System Control Interface.

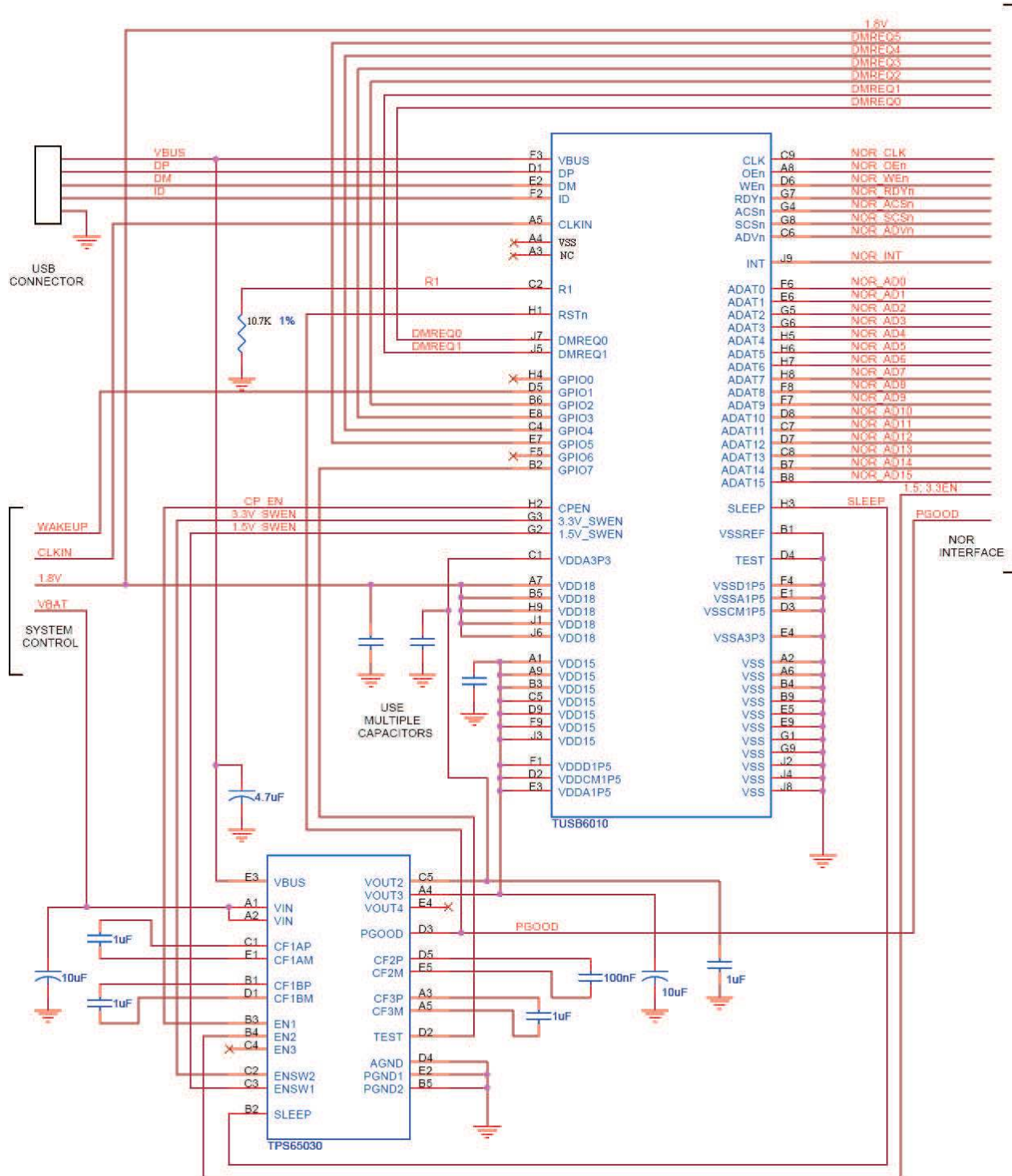

PRODUCT PREVIEW

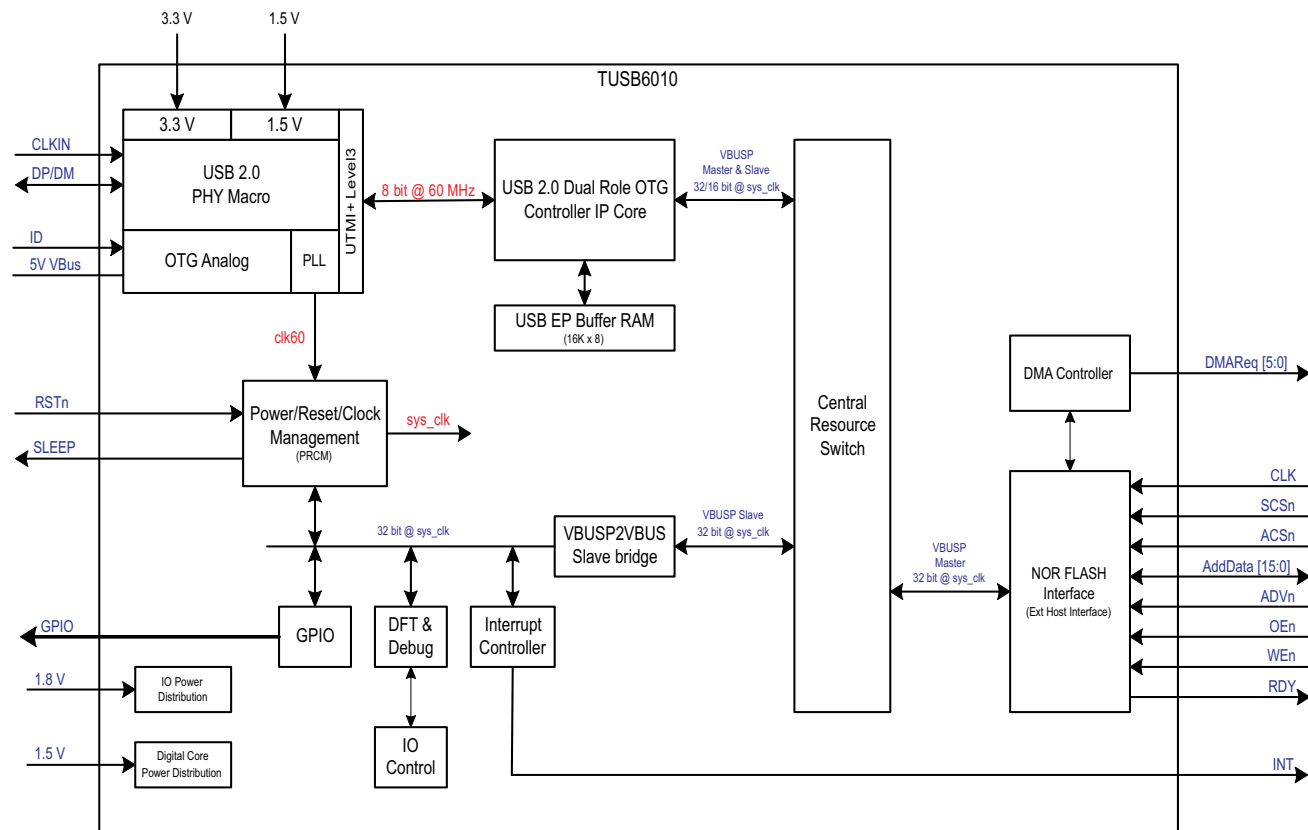
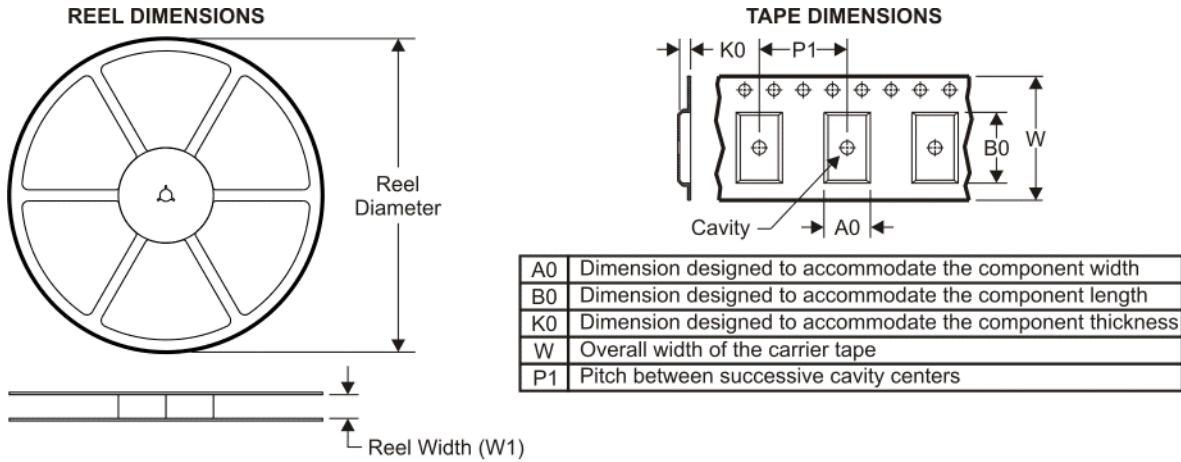

Figure 1. Device Block Diagram

PRODUCT PREVIEW

TAPE AND REEL INFORMATION



QUADRANT ASSIGNMENTS FOR PIN 1 ORIENTATION IN TAPE

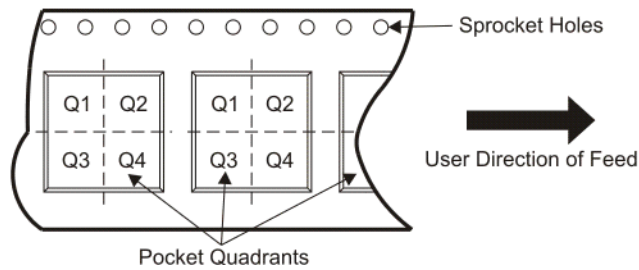

*All dimensions are nominal

| Device | Package Type | Package Drawing | Pins | SPQ | Reel Diameter (mm) | Reel Width W1 (mm) | A0 (mm) | B0 (mm) | K0 (mm) | P1 (mm) | W (mm) | Pin1 Quadrant |
|----------------|----------------------|-----------------|------|------|--------------------|--------------------|---------|---------|---------|---------|--------|---------------|
| TUSB6010BIZQER | BGA MICROSTAR JUNIOR | ZQE | 80 | 2500 | 330.0 | 12.4 | 5.3 | 5.3 | 1.5 | 8.0 | 12.0 | Q1 |

TAPE AND REEL BOX DIMENSIONS

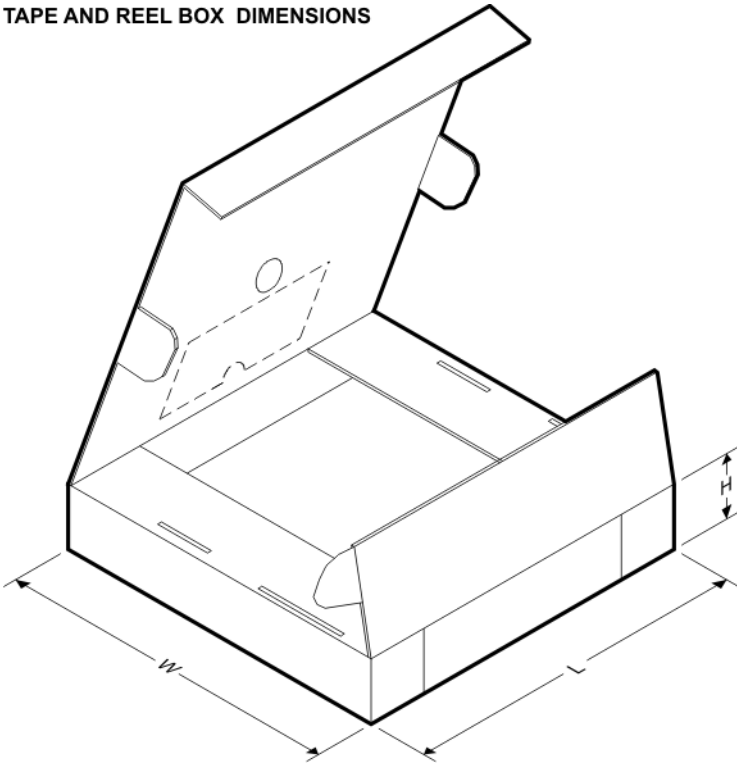

*All dimensions are nominal

| Device | Package Type | Package Drawing | Pins | SPQ | Length (mm) | Width (mm) | Height (mm) |
|----------------|----------------------|-----------------|------|------|-------------|------------|-------------|
| TUSB6010BIZQER | BGA MICROSTAR JUNIOR | ZQE | 80 | 2500 | 340.5 | 333.0 | 20.6 |

IMPORTANT NOTICE

Texas Instruments Incorporated and its subsidiaries (TI) reserve the right to make corrections, modifications, enhancements, improvements, and other changes to its products and services at any time and to discontinue any product or service without notice. Customers should obtain the latest relevant information before placing orders and should verify that such information is current and complete. All products are sold subject to TI's terms and conditions of sale supplied at the time of order acknowledgment.

TI warrants performance of its hardware products to the specifications applicable at the time of sale in accordance with TI's standard warranty. Testing and other quality control techniques are used to the extent TI deems necessary to support this warranty. Except where mandated by government requirements, testing of all parameters of each product is not necessarily performed.

TI assumes no liability for applications assistance or customer product design. Customers are responsible for their products and applications using TI components. To minimize the risks associated with customer products and applications, customers should provide adequate design and operating safeguards.

TI does not warrant or represent that any license, either express or implied, is granted under any TI patent right, copyright, mask work right, or other TI intellectual property right relating to any combination, machine, or process in which TI products or services are used. Information published by TI regarding third-party products or services does not constitute a license from TI to use such products or services or a warranty or endorsement thereof. Use of such information may require a license from a third party under the patents or other intellectual property of the third party, or a license from TI under the patents or other intellectual property of TI.

Reproduction of TI information in TI data books or data sheets is permissible only if reproduction is without alteration and is accompanied by all associated warranties, conditions, limitations, and notices. Reproduction of this information with alteration is an unfair and deceptive business practice. TI is not responsible or liable for such altered documentation. Information of third parties may be subject to additional restrictions.

Resale of TI products or services with statements different from or beyond the parameters stated by TI for that product or service voids all express and any implied warranties for the associated TI product or service and is an unfair and deceptive business practice. TI is not responsible or liable for any such statements.

TI products are not authorized for use in safety-critical applications (such as life support) where a failure of the TI product would reasonably be expected to cause severe personal injury or death, unless officers of the parties have executed an agreement specifically governing such use. Buyers represent that they have all necessary expertise in the safety and regulatory ramifications of their applications, and acknowledge and agree that they are solely responsible for all legal, regulatory and safety-related requirements concerning their products and any use of TI products in such safety-critical applications, notwithstanding any applications-related information or support that may be provided by TI. Further, Buyers must fully indemnify TI and its representatives against any damages arising out of the use of TI products in such safety-critical applications.

TI products are neither designed nor intended for use in military/aerospace applications or environments unless the TI products are specifically designated by TI as military-grade or "enhanced plastic." Only products designated by TI as military-grade meet military specifications. Buyers acknowledge and agree that any such use of TI products which TI has not designated as military-grade is solely at the Buyer's risk, and that they are solely responsible for compliance with all legal and regulatory requirements in connection with such use.

TI products are neither designed nor intended for use in automotive applications or environments unless the specific TI products are designated by TI as compliant with ISO/TS 16949 requirements. Buyers acknowledge and agree that, if they use any non-designated products in automotive applications, TI will not be responsible for any failure to meet such requirements.

Following are URLs where you can obtain information on other Texas Instruments products and application solutions:

Products

| | |
|-----------------------------|--|
| Amplifiers | amplifier.ti.com |
| Data Converters | dataconverter.ti.com |
| DSP | dsp.ti.com |
| Clocks and Timers | www.ti.com/clocks |
| Interface | interface.ti.com |
| Logic | logic.ti.com |
| Power Mgmt | power.ti.com |
| Microcontrollers | microcontroller.ti.com |
| RFID | www.ti-rfid.com |
| RF/IF and ZigBee® Solutions | www.ti.com/lprf |

Applications

| | |
|--------------------|--|
| Audio | www.ti.com/audio |
| Automotive | www.ti.com/automotive |
| Broadband | www.ti.com/broadband |
| Digital Control | www.ti.com/digitalcontrol |
| Medical | www.ti.com/medical |
| Military | www.ti.com/military |
| Optical Networking | www.ti.com/opticalnetwork |
| Security | www.ti.com/security |
| Telephony | www.ti.com/telephony |
| Video & Imaging | www.ti.com/video |
| Wireless | www.ti.com/wireless |

Mailing Address: Texas Instruments, Post Office Box 655303, Dallas, Texas 75265
Copyright © 2008, Texas Instruments Incorporated