

YIC



Ultra Low Power & Multi-Constellation GNSS Module YIC51612EBGGB

Datasheet

www.yic.com.tw

Revision History

Date	Reversion	Description
2022/11/15	1.0	First Draft, Based on YIC51612EBGGB
2023/4/11	2.0	Updated GPS L1 current

Directory

Revision History	2
1. Product Information	4
1.1 Product Description.....	4
1.2 Product Features	4
1.3 Product Specifications	5
1.4 DC Electrical Characteristics	6
2. Block Diagram	7
3. Module Pin Assignment	7
3.1 Pin Descriptions	8
4. Dimensions	9
5. Recommended Footprint	9
6. Reflow Profile	10
7. Tape & Reel	10
8. Application Circuit	11
8.1 Application Circuit of YIC51612EBGGB.....	11
8.2 Layout Notes.....	11
9. Software Protocol	12
9.1 NMEA output message	12
9.2 GGA – Global Positioning System Fix Data	13
9.3 GLL – Latitude/Longitude	14
9.4 GSA – GNSS DOP and Active Satellites	15
9.5 GSV – GNSS Satellites in View	16
9.6 RMC – Recommended Minimum Specific GNSS Data.....	17
9.7 VTG – Course Over Ground and Ground Speed	18
9.8 ZDA – TIME AND DATE	19

1. Product Information

1.1 Product Description

The YIC51612EBGGB features multi-constellation and ultra-low power consumption, with a highly integrated GNSS receiver chip built in to support multi-system Cortex®-M4F.

The YIC51612EBGGB supports concurrent reception of four GNSS (GPS, GLONASS, BeiDou, and Galileo) and augmentation systems (SBAS and QZSS). The multi-constellation enables the module to achieve an accuracy of approximately 1.5M and stable GNSS performance especially in challenging environments.

Applications

- Automotive Navigation
- Personal Positioning
- Fleet Management
- Marine Navigation
- Mobile phone Navigation
- Wearable and Portable

1.2 Product Features

- Multi-constellation GPS/GLONASS/Galileo/BeiDou, QZSS and SBAS
- Ultra-Low Power Consumption in Fitness Mode: 7.2 mA@3.3V
- Ultra High Track Sensitivity: -165dBm
- Multipath detection and suppression
- Works with passive and active antenna
- Extremely Fast TTFF at Low Signal Level (Cold start $\leq 24s$, Hot start $\leq 1s$)
- NMEA-0183 Compliant Protocol or Custom Protocol
- RoHS Compliant

1.3 Product Specifications

GPS Receiver		
Chip	MediaTek	
GNSS Reception	GPS/QZSS	L1 C/A, L1C
	BeiDou	B1I
	GLONASS	L1
	Galileo	E1
	SBAS	WAAS, EGNOS, MSAS, GAGAN
Update Rate	GNSS	10Hz Max. 1Hz by default
Position Accuracy	GNSS	1.5m CEP
	SBAS	1.5m CEP
Velocity & Time Accuracy	GNSS	0.01m/s CEP
	SBAS	0.05 m/s
	1PPS	25 ns
Accuracy Time	Hot start	1 sec
	Cold start	24 sec
Sensitivity	Cold start	-148dBm
	Hot start	-155dBm
	Tracking	-165dBm
	Reacquisition	-158dBm
GNSS Operating limit	Velocity	515m/s
	Altitude	10,000m (Default), 80,000m in Balloon Mode
Protocol Support	UART Port: TXD and RXD 115200bps (default), Supports baud rate 9600bps to 921600bps NMEA 0183 Protocol	
Environment	Operation temperature	-40°C ~ +85°C
	Storage temperature	-55°C ~ +100°C
Physical Characteristics	Size	16±0.15 × 12.2±0.15 × 2.6±0.1mm
	Weight	Approx. 1.1g

1.4 DC Electrical Characteristics

Parameter		Min.	Typ.	Max.	Units
Input Voltage		2.8	3.3	3.6	Volt
Power Supplier Current					
Acquisition	GPS L1*		9.5		mA
	GPS L1 + GL + GA + BD		11		mA
Tracking	GPS L1*		7.2		mA
	GPS L1 + GL + GA + BD		12		mA
UART Port Working Voltage					
Low Level Output Voltage (VOL)				0.4	Volt
High Level Output Voltage (VOH)		2.4			Volt
Low Level Input Voltage (VIL)				0.8	Volt
High Level Input Voltage (VIH)		2.1			Volt
Low Level Output Current (IOL)		10			uA
High Level Output Current (IOH)		-10			uA

* : Based on fitness mode.

2. Block Diagram

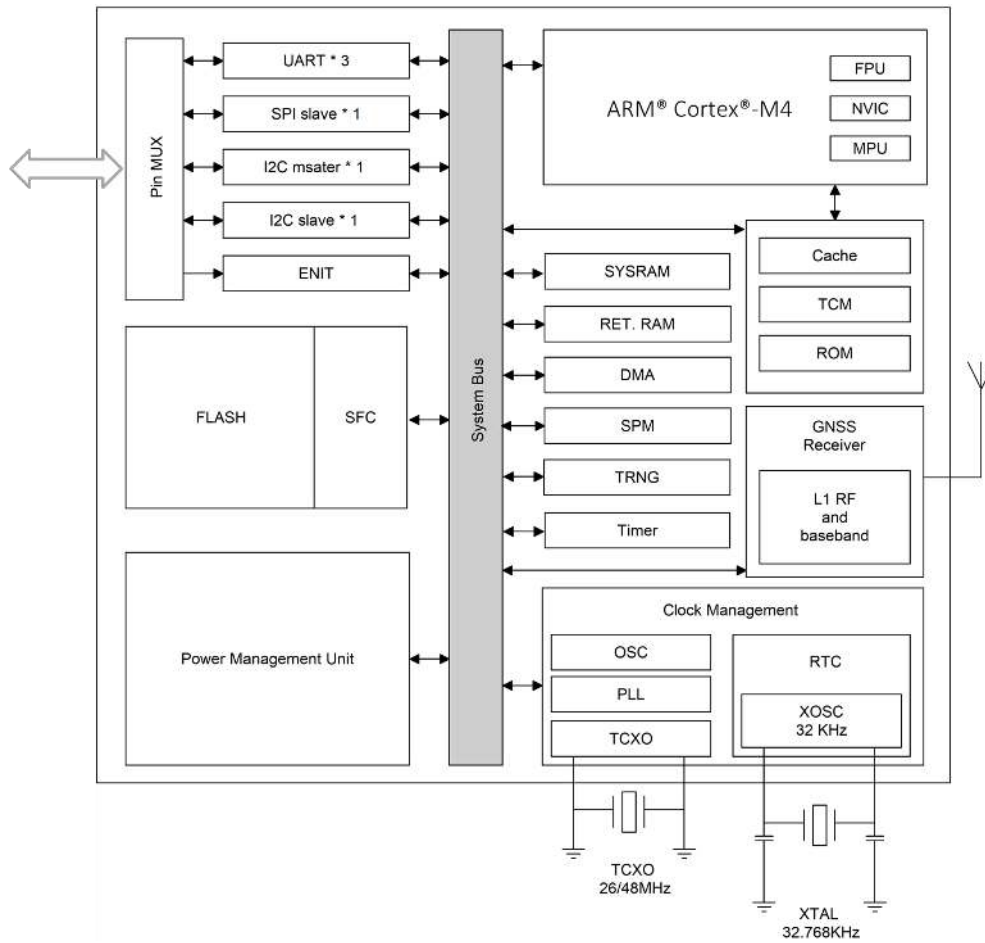

3. Module Pin Assignment

13	GND	GND	12
14	NC	RF_IN	11
15	NC	GND	10
16	TXD1	RF_VCC	9
17	RXD1	CHIP_EN	8
YIC51612EBGGB			
Top View			
18	TXD2	NC	7
19	RXD2	NC	6
20	TXD0	NC	5
21	RXD0	RTC_ENIT	4
22	V_BCKP	PPS	3
23	VCC	SDA	2
24	GND	SCL	1

3.1 Pin Descriptions

Pin NO.	Pin Name	Remark
1	SCL	No connection
2	SDA	No connection
3	PPS	Time pulse (1PPS) (if not used, must be left floating)
4	RTC_EINT	Interrupt pin; If the external high level is greater than 10ms, the module exits the RTC mode (Hang when not in use)
5	NC	No connection
6	NC	No connection
7	NC	No connection
8	CHIP_EN	Low level active. If unused, keep this pin open or connect in to Vcc
9	RF_VCC	Output power supply for external LNA or active antenna
10	GND	Ground
11	RF_IN	RF signal input
12	GND	Ground
13	GND	Ground
14	NC	No connection
15	NC	No connection
16	TXD1	Reserved debugging port (Idle)
17	RXD1	Reserved debugging port (Idle)
18	TXD2	Standby serial port output
19	RXD2	Standby serial port input
20	TXD0	UART serial data output
21	RXD0	UART serial data input
22	V_BCKP	Backup power supply, The V_BCKP pin can be directly supplied power by battery or connect it to VCC
23	VCC	Main power supply, 3.3V Typical
24	GND	Ground

4. Dimensions

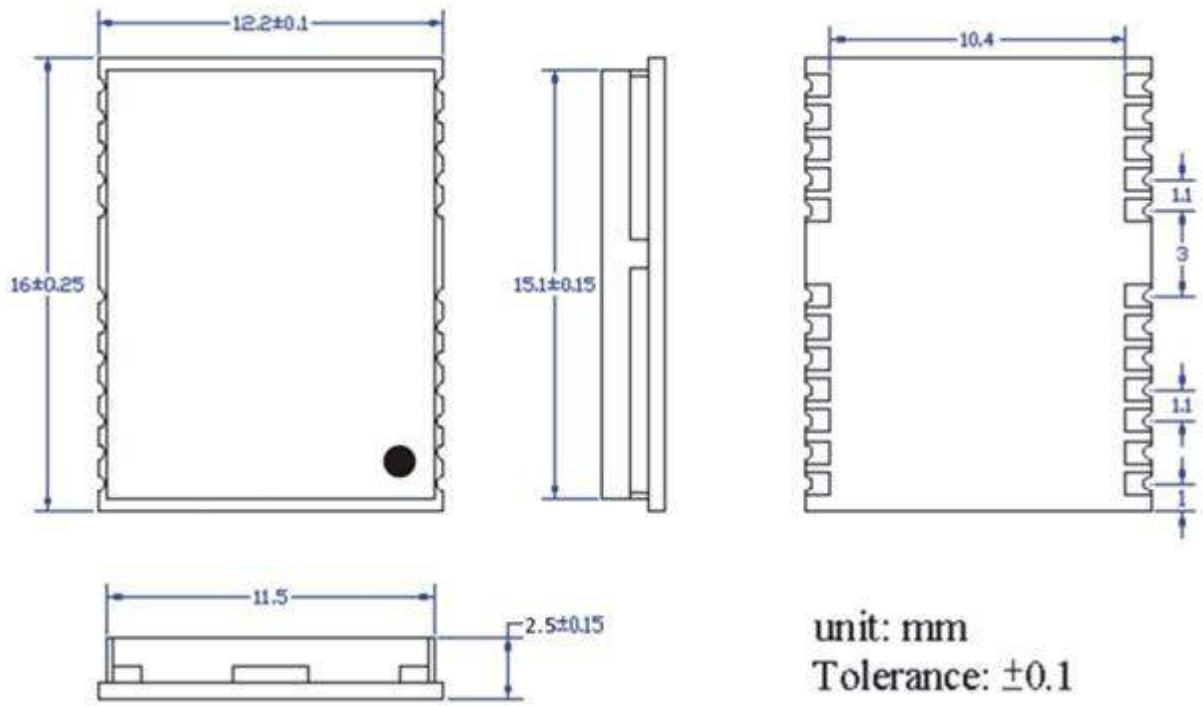

5. Recommended Footprint

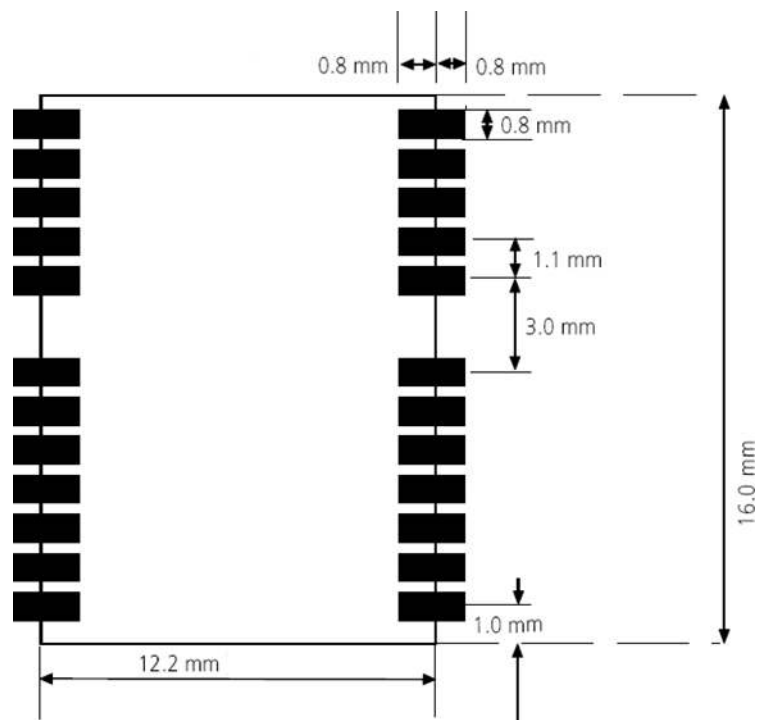

6. Reflow Profile

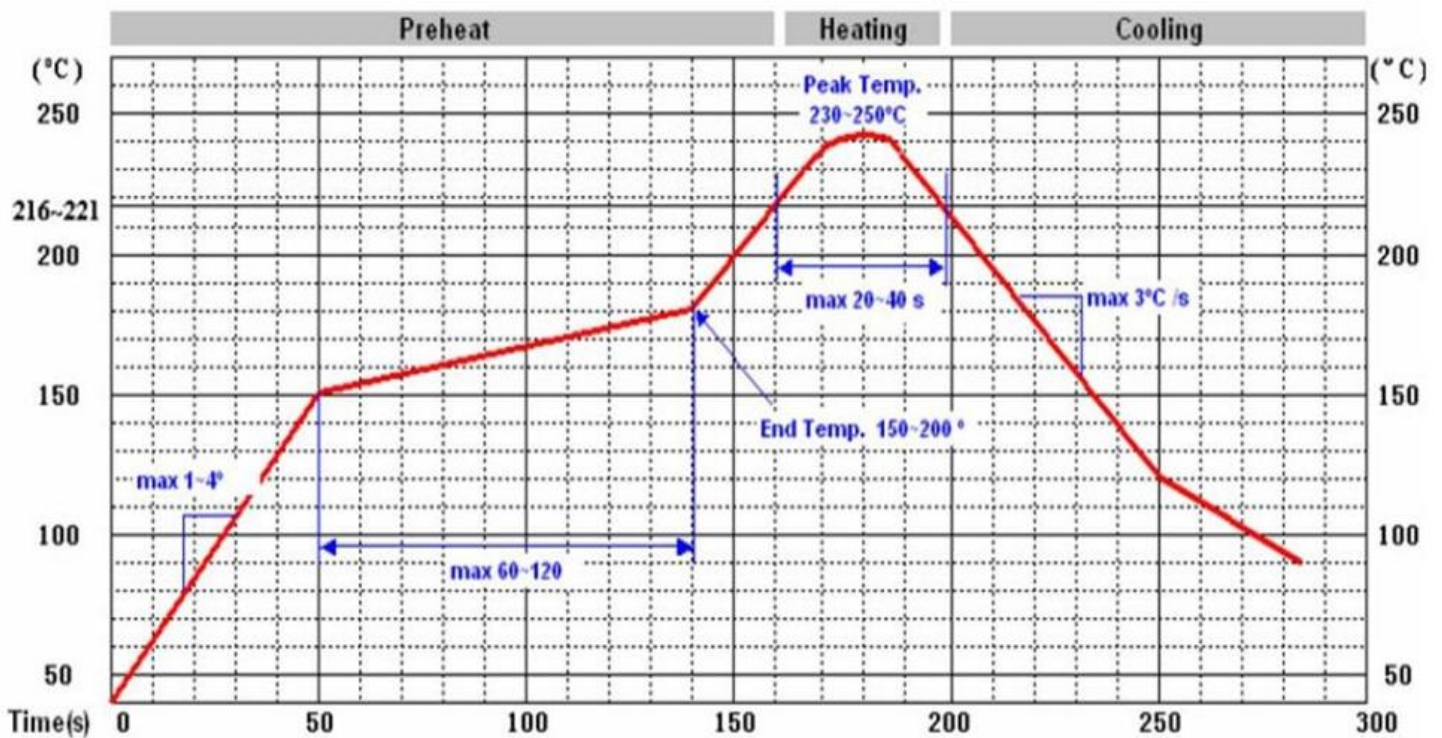

☆ The absolute maximum reflow temperature is 260°C. Repeated reflow soldering processes or soldering the module upside down are not recommended.

☆ Modules must not be soldered with a damp heat process.

7. Tape & Reel

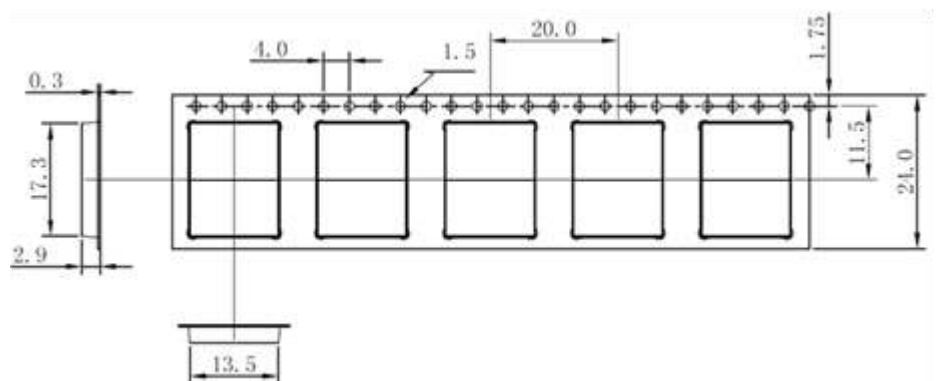

Unit: mm

8. Application Circuit

8.1 Application Circuit of YIC51612EBGGB

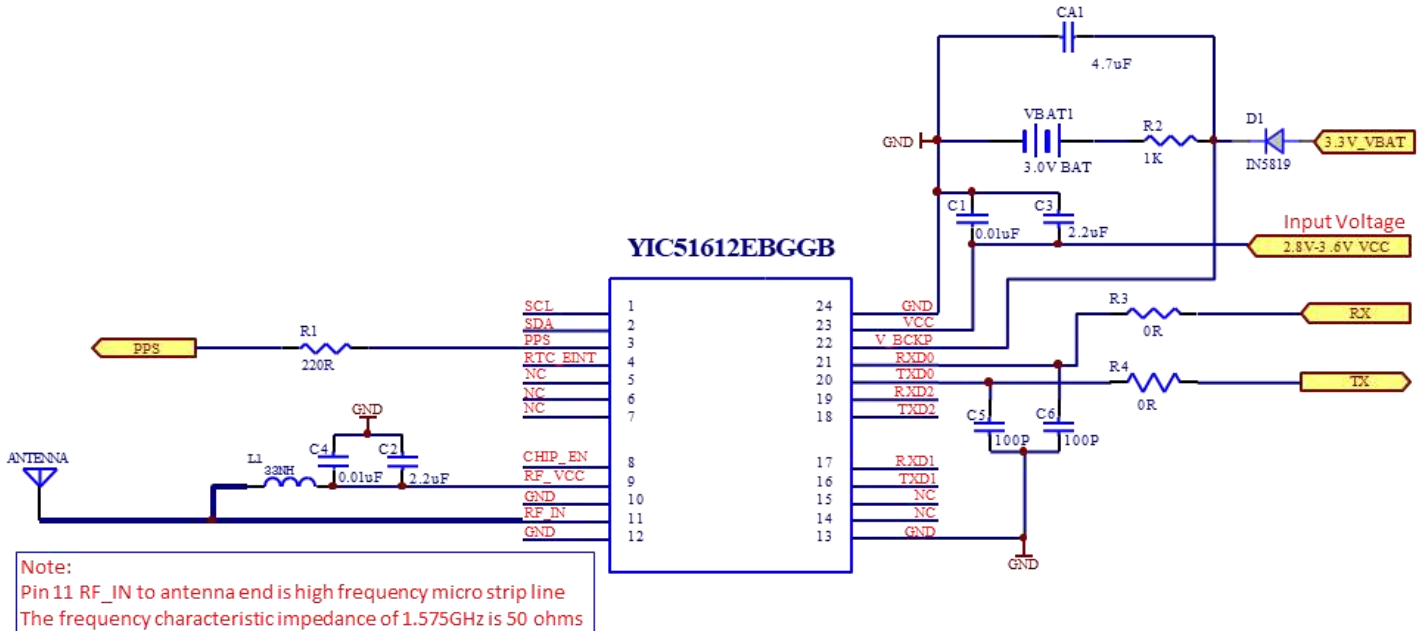

8.2 Layout Notes

1. A decoupling capacitor should be placed close to VDD pin of the module, and the width of power routing should be more than 0.5mm.
2. The characteristic impedance of RF routing between RF port to antenna should be controlled to 50 Ω .
3. Do not place the module close to any EMI source, RF routing, clock signal or other high-frequency switching signal, etc.

9. Software Protocol

9.1 NMEA output message

NMEA	Description
\$GNGGA	Time, position, and fix related data of the receiver.
\$GNGLL	Position, time and fix status.
\$GNGSA	Used to represent the ID of satellites which are used for position fix. When GPS & GLONASS & Galileo & BDS satellites are used for positioning solutions, the ID of available positioning satellites is counted and output with multiple statements.
\$GPGSV \$GLGSV \$GAGSV \$GBGSV	Satellite information about elevation, azimuth and CNR, satellites are used in position solution, \$GPGSV sentence is used for GPS satellites, a \$GLGSV sentence is used for GLONASS satellites, \$GAGSV sentence is used for GALILEO satellites. And \$GBGSV sentence is used for BDS satellites.
\$GNRMC	Time, date, position, course and speed data.
\$GNVTG	Course and speed relative to the ground.
\$GNZDA	UTC, day, month and year and time zone.

9.2 GGA – Global Positioning System Fix Data

Time, position and fix related data for a GNSS receiver.

Structure:

\$GNGGA,hhmmss.sss,ddmm.mmmm,a,dddmm.mmmm,a,x,xx,x.x,x.x,M,x.x,M,x.x,xxxx*hh

example: \$GNGGA,175258.000,2447.0870,N,12100.5221,E,2,15,0.7,95.2,M,19.6,M,,0000*72

Field	Name	Example	Description
1	UTC Time	175258.000	UTC of position in hhmmss.sss format, (000000.000 ~ 235959.999)
2	Latitude	2447.08700	Latitude in ddmm.mmmmm format Leading zeros transmitted
3	N/S Indicator	N	Latitude hemisphere indicator, 'N' = North, 'S' = South
4	Longitude	12100.52210	Longitude in dddmm.mmmmm format Leading zeros transmitted
5	E/W Indicator	E	Longitude hemisphere indicator, 'E' = East, 'W' = West
6	Quality Indicator	2	Quality Indicator 0: position fix unavailable 1: valid position fix, SPS mode 2: valid position fix, differential GPS mode 3: GPS PPS Mode, fix valid 6: Estimated (dead reckoning) Mode
7	Satellites Used	15	Number of satellites in use, (00 ~ 56)
8	HDOP	0.7	Horizontal dilution of precision, (0.0 ~ 99.9)
9	Altitude	95.2	mean sea level (geoid), (-9999.9 ~ 17999.9)
10	Geoidal Separation	19.6	Geoidal separation in meters
11	Age of Differential GPS data		Age of Differential GPS data NULL when DGPS not used
12	DGPS Station ID	0000	Differential reference station ID, 0000 ~ 1023
13	Checksum	72	

9.3 GLL – Latitude/Longitude

Latitude and longitude of current position, time, and status.

Structure: \$GNGLL,ddmm.mmmm,a,dddmm.mmmm,a,hhmmss.sss,A,a*hh

For example: \$GNGLL,2447.0870,N,12100.5221,E,175258.000,A,D*42

Field	Name	Example	Description
1	Latitude	2447.08700	Latitude in ddmm.mmmmm format Leading zeros transmitted
2	N/S Indicator	N	Latitude hemisphere indicator 'N' = North 'S' = South
3	Longitude	12100.52210	Longitude in dddmm.mmmmm format Leading zeros transmitted
4	E/W Indicator	E	Longitude hemisphere indicator 'E' = East 'W' = West
5	UTC Time	175258.000	UTC time in hhmmss.sss format (000000.000 ~ 235959.999)
6	Status	A	Status, 'A' = Data valid, 'V' = Data not valid
7	Mode Indicator	D	Mode indicator 'N' = Data not valid 'A' = Autonomous mode 'D' = Differential mode 'E' = Estimated (dead reckoning) mode
8	Checksum	42	

9.4 GSA – GNSS DOP and Active Satellites

GNSS receiver operating mode, satellites used in the navigation solution reported by the GGA sentence and DOP values.

Structure: \$GNGSA,A,x,xx,xx,xx,xx,xx,xx,xx,xx,xx,xx,xx,x.x,x.x,x.x,x*hh

For example: \$GNGSA,A,3,21, 12,15,18,20,24,10,32,25,13,,,1.2,0.7,1.0,1*18

Field	Name	Example	Description
1	Mode	A	Mode 'M' = Manual, forced to operate in 2D or 3D mode 'A' = Automatic, allowed to automatically switch 2D/3D
2	Mode	3	Fix type 1 = Fix not available 2 = 2D 3 = 3D
3	Satellite used 1~12	21, 12, 15, 18, 20, 24, 10, 32,25, 13	01 ~ 32 are for GPS; 33 ~ 64 are for WAAS (PRN minus 87); 193 ~ 197 are for QZSS; 65 ~ 88 are for GLONASS (GL PRN) ; 01 ~ 36 are for GALILEO (GA PRN); 01 ~ 37 are for BDS (BD PRN). GPS, GLONASS, GALILEO and BDS satellites are differentiated by the. GNSS system ID in table 3. Maximally 12 satellites are included in each GSA sentence.
4	PDOP	1.2	Position dilution of precision (0.0 to 99.9)
5	HDOP	0.7	Horizontal dilution of precision (0.0 to 99.9)
6	VDOP	1.0	Vertical dilution of precision (0.0 to 99.9)
7	GNSS System ID	1	1 for GPS, 2 for GLONASS, 3 for GALILEO, 4 for BDS
8	Checksum	18	

9.5 GSV – GNSS Satellites in View

Number of satellites (SV) in view, satellite ID numbers, elevation, azimuth, and SNR value. Four satellites maximum per transmission.

Structure: \$GPGSV , x , x , xx , xx , xx , xx , xx , ... , xx , xx , xx , xx , xx , x*hh

For example: \$GPGSV , 4,1 , 13 , 02,72 , 109 , 43,24 , 69,035 , 48,18 , 52,330 , 42,21 , 49,246 , 43 , 1*69

Field	Name	Example	Description
1	Number of message	4	Total number of GSV messages to be transmitted (1-5)
2	Sequence number	1	Sequence number of current GSV message
3	Satellites in view	13	Total number of satellites in view (00 ~ 20)
4	Satellite ID	02	01 ~ 32 are for GPS; 33 ~ 64 are for WAAS (PRN minus 87); 193 ~ 197 are for QZSS; 65 ~ 88 are for GLONASS (GL PRN) ; 01 ~ 36 are for GALILEO (GA PRN); 01 ~ 37 are for BDS (BD PRN). GPS, GLONASS, GALILEO and BDS satellites are differentiated by the GNSS system ID in table 3. Maximally 12 satellites are included in each GSA sentence
5	Elevation	72	Satellite elevation in degrees, (00 ~ 90)
6	Azimuth	109	Satellite azimuth angle in degrees, (000 ~ 359)
7	SNR	43	C/No in dB (00 ~ 99) Null when not tracking
8	Signal ID	1	1 for L1/CA
9	Checksum	69	

9.6 RMC – Recommended Minimum Specific GNSS Data

Time, date, position, course and speed data provided by a GNSS navigation receiver.

Structure: \$GNRMC,hhmmss.sss,A,dddmm.mmmmm,a,dddmm.mmmmm,a,x.x,x.x,ddmmyy,,,a*hh For example:

\$GNRMC,175258.000,A,2447.0870,N,12100.5220,E,000.0,000.0,220617,,,D*75

Field	Name	Example	Description
1	UTC time	175258.000	UTC time in hhmmss.sss format (000000.00 ~ 235959.999)
2	Status	A	Status 'V' = Navigation receiver warning 'A' = Data Valid
3	Latitude	2447.08700	Latitude in dddmm.mmmmm format Leading zeros transmitted
4	N/S indicator	N	Latitude hemisphere indicator 'N' =North 'S' = South
5	Longitude	12100.52210	Longitude in dddmm.mmmmm format Leading zeros transmitted
6	E/W Indicator	E	Longitude hemisphere indicator 'E' = East 'W' = West
7	Speed over ground	000.0	Speed over ground in knots (000.0 ~ 999.9)
8	Course over ground	000.0	Course over ground in degrees (000.0 ~ 359.9)
9	UTC Date	220617	UTC date of position fix, ddmmyy format
10	Mode indicator	D	Mode indicator 'N' = Data not valid 'A' = Autonomous mode 'D' = Differential mode 'E' = Estimated (dead reckoning) mode
11	checksum	75	

9.7 VTG – Course Over Ground and Ground Speed

The actual course and speed relative to the ground.

Structure: \$GNVTG,x.x,T,,M,x.x,N,x.x,K,a*hh

For example: \$GNVTG,000.0,T,,M,000.0,N,000.0,K,D*16

Field	Name	Example	Description
1	Course	000.0	True course over ground in degrees (000.0 ~ 359.9)
2	Speed	000.0	Speed over ground in knots (000.0 ~ 999.9)
3	Speed	000.0	Speed over ground in kilometers per hour (000.0 ~ 1800.0)
4	Mode	D	Mode indicator 'N' = Data not valid 'A' = Autonomous mode 'D' = Differential mode 'E' = Estimated (dead reckoning) mode
5	Checksum	16	

9.8 ZDA – TIME AND DATE

UTC, day, month, year and local time zone

Structure:

```
$GNZDA,hhmmss.sss,xx,xx,xxxx,xx,xx*hh<CR><LF>
```

For example:

```
$GNZDA,175258.000,30,08,2022,00,00*46<CR><LF>
```

Field	Name	Example	Units	Description
1	UTC time	175258.000		UTC time in hhmmss.ss format (000000.00 ~ 235959.99)
2	UTC Day	30		UTC time: day (01 ~ 31)
3	UTC Month	28		UTC time: month (01 ~ 12)
4	UTC Year	2022		UTC time: year (4 digit format)
5	Local zone hour	00		Local zone hours (00 ~ +/- 13)
6	Local zone minutes	00		Local zone minutes (00 ~59)
7	Checksum	46		Checksum

★ZDA is optional