

4

3

2

1

THIS DRAWING IS UNPUBLISHED. RELEASED FOR PUBLICATION 20  
 © COPYRIGHT 20 BY - ALL RIGHTS RESERVED.

REVISIONS				
P	LTR	DESCRIPTION	DATE	APVD
	A	INITIAL	04JUN2015	DW CW
	A1	ECR-16-004419	28MAR2016	DW CW
	B	ECR-20-014876	18NOV2020	WOR CW

TYPE 1: LOW CONSTRUCTION, SIDE ENTRY  
 类型1: 低结构, 侧出

NOTES:

1. TECHNICAL CHARACTERISTICS:  
 HOOD MATERIAL: DIE CAST ALUMINIUM ALLOY  
 SURFACE: POWDER COATED, GREY  
 DEGREE OF PROTECTION: IP65 (MATED)

注释:

1. 技术参数:  
 上壳材料: 铝合金  
 表面处理: 灰色粉末喷涂  
 防护等级: IP65 (配合)

TYPE 2: LOW CONSTRUCTION, TOP ENTRY  
 类型2: 低结构, 高出

THIS DRAWING IS A CONTROLLED DOCUMENT.		DWN DAVID WANG 04JUN2015	<b>STE</b> TE Connectivity	
		CHK CHRIS WANG 04JUN2015		
DIMENSIONS: mm		APVD XIANG XU 04JUN2015	NAME H24B-TS/TG/TSH/TGH-RO-M/PG	
TOLERANCES UNLESS OTHERWISE SPECIFIED:		PRODUCT SPEC 108-137013	SIZE CAGE CODE DRAWING NO RESTRICTED TO	
0 PLC ±		APPLICATION SPEC 114-137013	A200779 C-T13X02401XX000	
1 PLC ±		WEIGHT -	SCALE 1:2 SHEET 1 OF 3 REV B	
2 PLC ±		CUSTOMER DRAWING		
3 PLC ±				
4 PLC ±				
ANGLES ±				
FINISH -				

1471-9 (3/13)

THIS DRAWING IS UNPUBLISHED. RELEASED FOR PUBLICATION 20  
 © COPYRIGHT 20 BY - ALL RIGHTS RESERVED.

REVISIONS				
P	LTR	DESCRIPTION	DATE	APVD
-	-	SEE SHEET 1	-	-

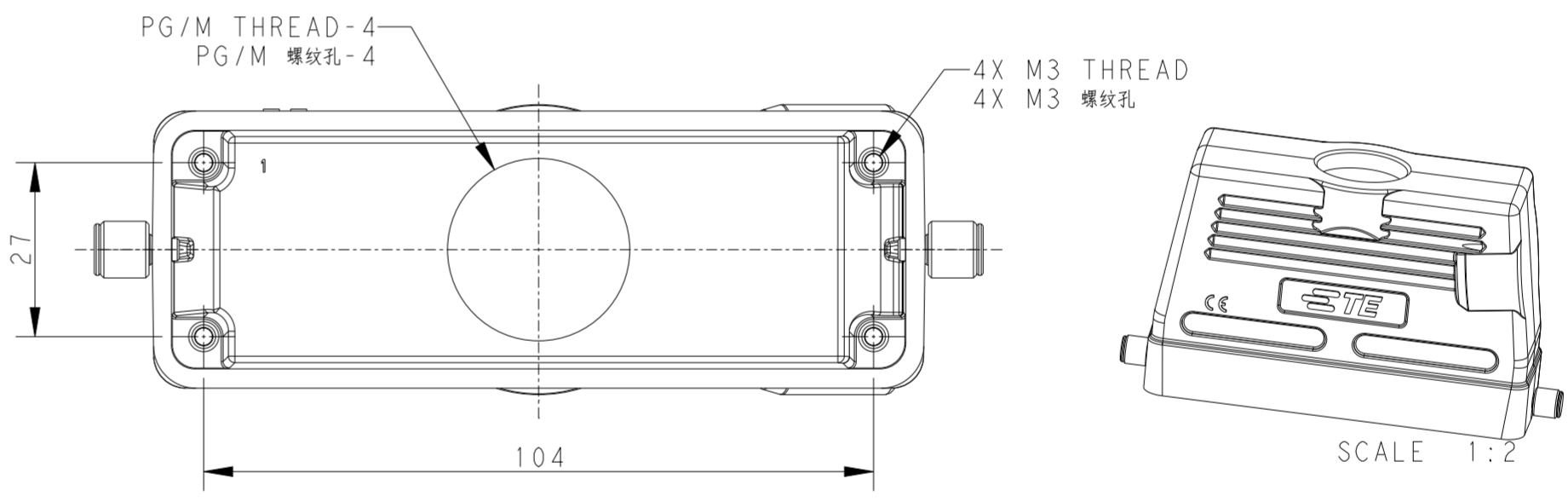
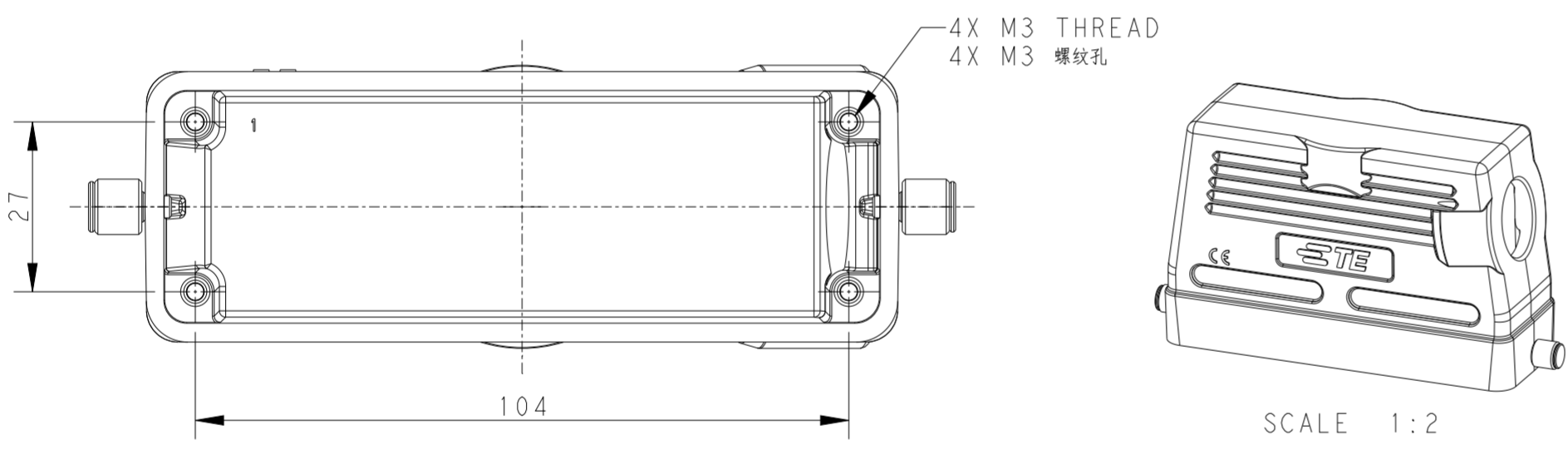
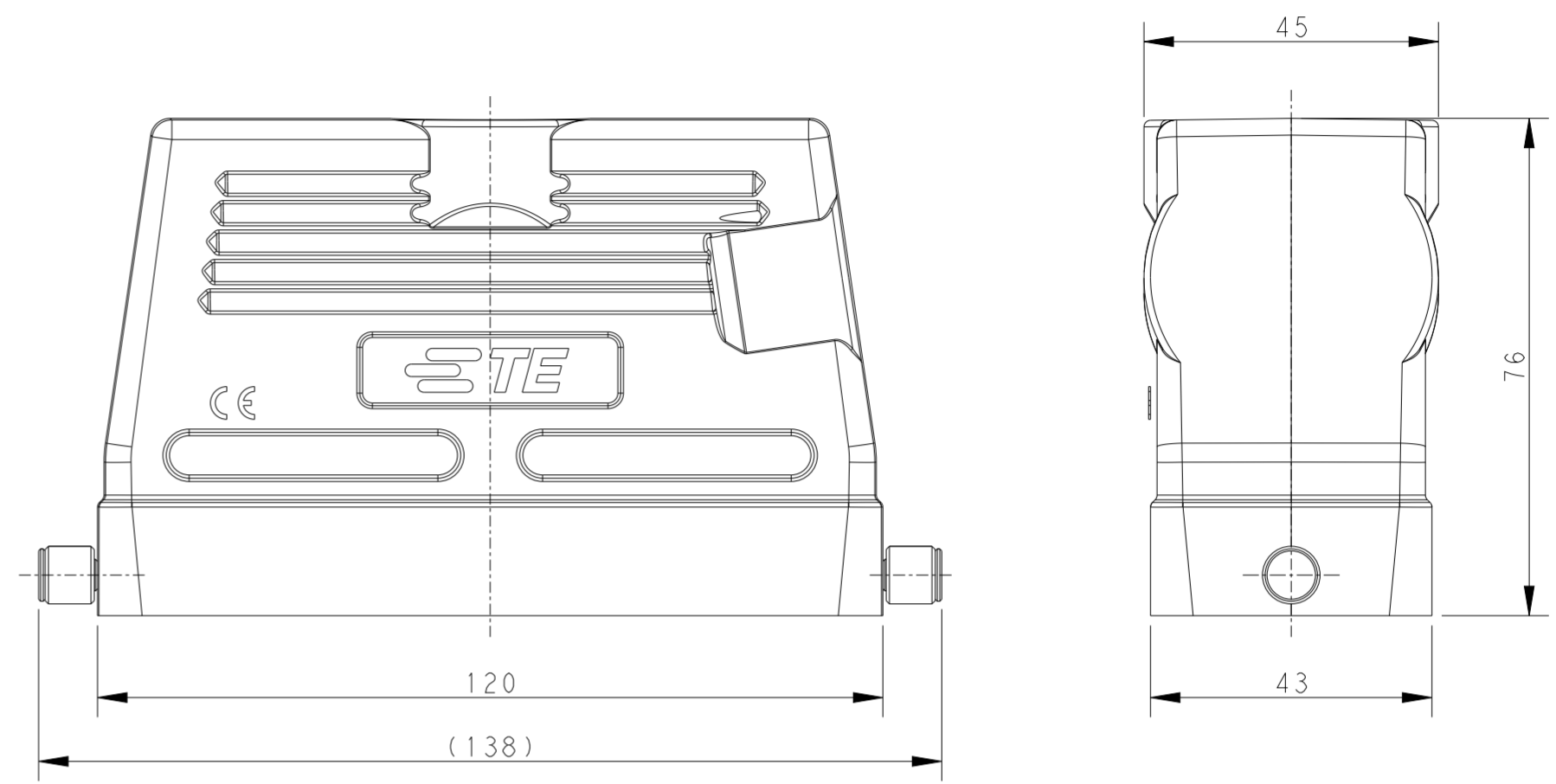
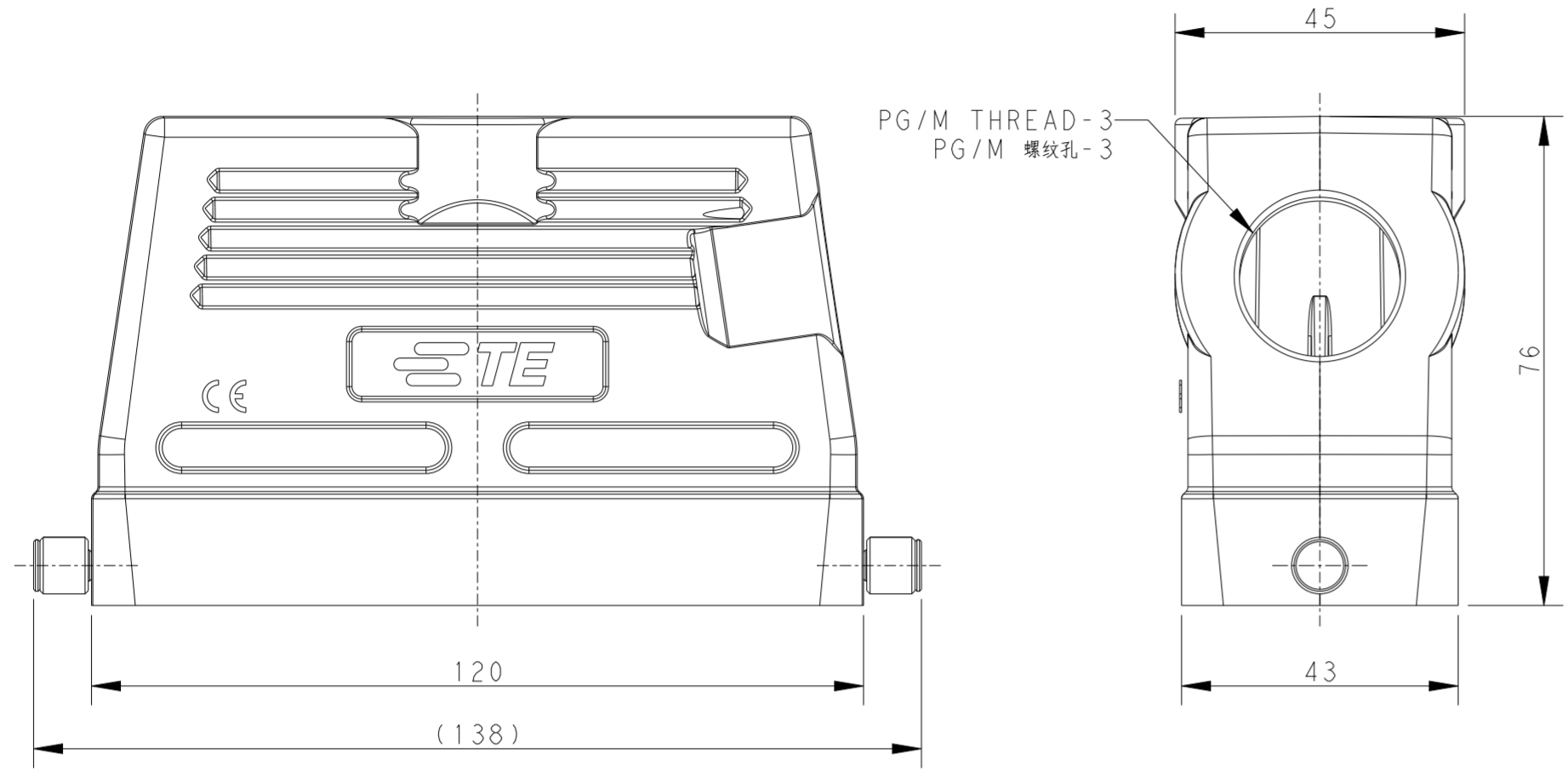

TYPE 3: HIGH CONSTRUCTION, SIDE ENTRY  
 类型3: 高结构, 侧出

TYPE 4: HIGH CONSTRUCTION, TOP ENTRY  
 类型4: 高结构, 顶出

NOTES:  
 SEE SHEET 1

THIS DRAWING IS A CONTROLLED DOCUMENT.		DWN DAVID WANG 04JUN2015	<b>STE</b> TE Connectivity	
DIMENSIONS: mm		CHK CHRIS WANG 04JUN2015		
TOLERANCES UNLESS OTHERWISE SPECIFIED:		APVD XIANG XU 04JUN2015	NAME H24B-TS/TG/TSH/TGH-RO-M/PG	
0 PLC ±	1 PLC ±	PRODUCT SPEC 108-137013	SIZE A2	CAGE CODE 00779
2 PLC ±	3 PLC ±	APPLICATION SPEC 114-137013	DRAWING NO C-T13X02401XX000	RESTRICTED TO -
4 PLC ±	ANGLES ±	FINISH -	WEIGHT -	SCALE 1:1
MATERIAL -	FINISH -	CUSTOMER DRAWING	SHEET 2 OF 3	REV B

THIS DRAWING IS UNPUBLISHED. RELEASED FOR PUBLICATION 20  
 © COPYRIGHT 20 BY - ALL RIGHTS RESERVED.

REVISIONS					
P	LTR	DESCRIPTION	DATE	DWN	APVD
-		SEE SHEET 1	-	-	-

NOTES:  
SEE SHEET 1

PART NUMBER 零件料号	PART DESCRIPTION 零件描述	PG/M THREAD-1 PG/M 螺纹孔-1	PG/M THREAD-2 PG/M 螺纹孔-2	PG/M THREAD-3 PG/M 螺纹孔-3	PG/M THREAD-4 PG/M 螺纹孔-4	TYPE 类型
T1340240121-000	H24B HOOD, TOP ENTRY PG21, 2 EAR, HIGH CONSTRUCTION, POWDER COATED, GREY H24B上壳, 顶出PG21, 2耳, 高结构, 灰色粉末喷涂	-	-	-	PG21	TYPE 4 类型 4
T1340240125-000	H24B HOOD, TOP ENTRY M25, 2 EAR, HIGH CONSTRUCTION, POWDER COATED, GREY H24B上壳, 顶出M25, 2耳, 高结构, 灰色粉末喷涂	-	-	-	M25	
T1340240129-000	H24B HOOD, TOP ENTRY PG29, 2 EAR, HIGH CONSTRUCTION, POWDER COATED, GREY H24B上壳, 顶出PG29, 2耳, 高结构, 灰色粉末喷涂	-	-	-	PG29	
T1340240132-000	H24B HOOD, TOP ENTRY M32, 2 EAR, HIGH CONSTRUCTION, POWDER COATED, GREY H24B上壳, 顶出M32, 2耳, 高结构, 灰色粉末喷涂	-	-	-	M32	
T1340240140-000	H24B HOOD, TOP ENTRY M40, 2 EAR, HIGH CONSTRUCTION, POWDER COATED, GREY H24B上壳, 顶出M40, 2耳, 高结构, 灰色粉末喷涂	-	-	-	M40	
T1330240121-000	H24B HOOD, SIDE ENTRY PG21, 2 EAR, HIGH CONSTRUCTION, POWDER COATED, GREY H24B上壳, 侧出PG21, 2耳, 高结构, 灰色粉末喷涂	-	-	PG21	-	TYPE 3 类型 3
T1330240125-000	H24B HOOD, SIDE ENTRY M25, 2 EAR, HIGH CONSTRUCTION, POWDER COATED, GREY H24B上壳, 侧出M25, 2耳, 高结构, 灰色粉末喷涂	-	-	M25	-	
T1330240129-000	H24B HOOD, SIDE ENTRY PG29, 2 EAR, HIGH CONSTRUCTION, POWDER COATED, GREY H24B上壳, 侧出PG29, 2耳, 高结构, 灰色粉末喷涂	-	-	PG29	-	
T1330240132-000	H24B HOOD, SIDE ENTRY M32, 2 EAR, HIGH CONSTRUCTION, POWDER COATED, GREY H24B上壳, 侧出M32, 2耳, 高结构, 灰色粉末喷涂	-	-	M32	-	
T1330240140-000	H24B HOOD, SIDE ENTRY M40, 2 EAR, HIGH CONSTRUCTION, POWDER COATED, GREY H24B上壳, 侧出M40, 2耳, 高结构, 灰色粉末喷涂	-	-	M40	-	
T1320240121-000	H24B HOOD, TOP ENTRY PG21, 2 EAR, POWDER COATED, GREY H24B上壳, 顶出PG21, 2耳, 灰色粉末喷涂	-	PG21	-	-	TYPE 2 类型 2
T1320240125-000	H24B HOOD, TOP ENTRY M25, 2 EAR, POWDER COATED, GREY H24B上壳, 顶出M25, 2耳, 灰色粉末喷涂	-	M25	-	-	
T1320240129-000	H24B HOOD, TOP ENTRY PG29, 2 EAR, POWDER COATED, GREY H24B上壳, 顶出PG29, 2耳, 灰色粉末喷涂	-	PG29	-	-	
T1320240132-000	H24B HOOD, TOP ENTRY M32, 2 EAR, POWDER COATED, GREY H24B上壳, 顶出M32, 2耳, 灰色粉末喷涂	-	M32	-	-	
T1310240121-000	H24B HOOD, SIDE ENTRY PG21, 2 EAR, POWDER COATED, GREY H24B上壳, 侧出PG21, 2耳, 灰色粉末喷涂	PG21	-	-	-	TYPE 1 类型 1
T1310240125-000	H24B HOOD, SIDE ENTRY M25, 2 EAR, POWDER COATED, GREY H24B上壳, 侧出M25, 2耳, 灰色粉末喷涂	M25	-	-	-	
T1310240132-000	H24B HOOD, SIDE ENTRY M32, 2 EAR, POWDER COATED, GREY H24B上壳, 侧出M32, 2耳, 灰色粉末喷涂	M32	-	-	-	

THIS DRAWING IS A CONTROLLED DOCUMENT.

DWN	DAVID WANG	04 JUN 2015
CHK	CHRIS WANG	04 JUN 2015
APVD	XIANG XU	04 JUN 2015

**STE** TE Connectivity

NAME: H24B-TS/TG/TSH/TGH-RO-M/PG

PRODUCT SPEC: 108-137013

APPLICATION SPEC: 114-137013

SIZE: A2 CAGE CODE: 00779 DRAWING NO: T13X02401XX000 RESTRICTED TO: -

WEIGHT: -

Customer Drawing SCALE: 1:1 SHEET: 3 OF 3 REV: B