

CUSTOMER PRINT

PART NUMBER: SF3382-XFSG-5XX

**NOTES:**

1. PLACE (1) ONE OF EACH KIT, IN A BAG WITH INSTRUCTION SHEET AND SEALED.
2. LABEL WITH CONXALL, PART NUMBER, DATE CODE AND P/N BARCODE IS PLACED ON BAG.

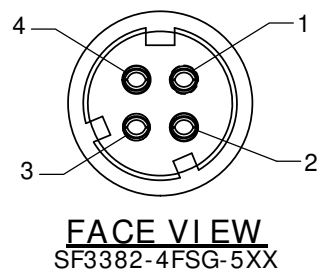
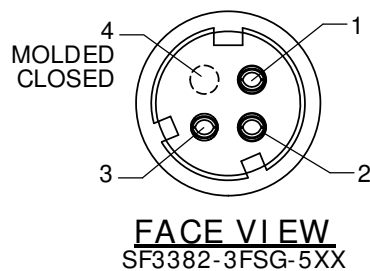
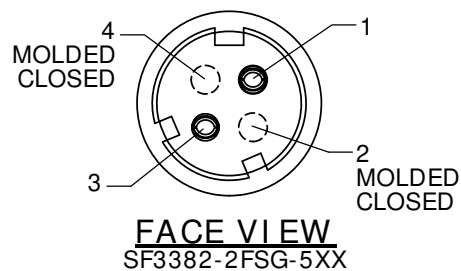

**CUSTOMER APPROVAL**

THIS DOCUMENT CONTAINS CONFIDENTIAL INFORMATION PROPRIETARY TO CONXALL CORPORATION. ANY REPRODUCTION, DISCLOSURE, OR USE OF THIS DOCUMENT / INFORMATION IS EXPRESSLY PROHIBITED UNLESS AUTHORIZED IN WRITING BY CONXALL CORPORATION.

APPROVED BY: \_\_\_\_\_

DATE: \_\_\_\_\_

PART NO.	CABLE I.D.
SF3382-XFSG-520	Ø .200
SF3382-XFSG-530	Ø .300
SF3382-XFSG-540	Ø .400

NO. OF CONATCTS: 2-4

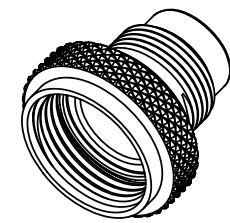
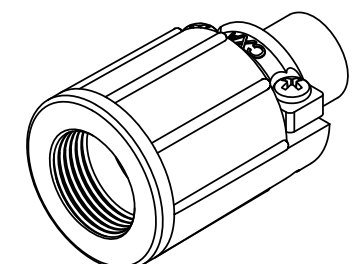

**F-KEYING INSERT KIT**

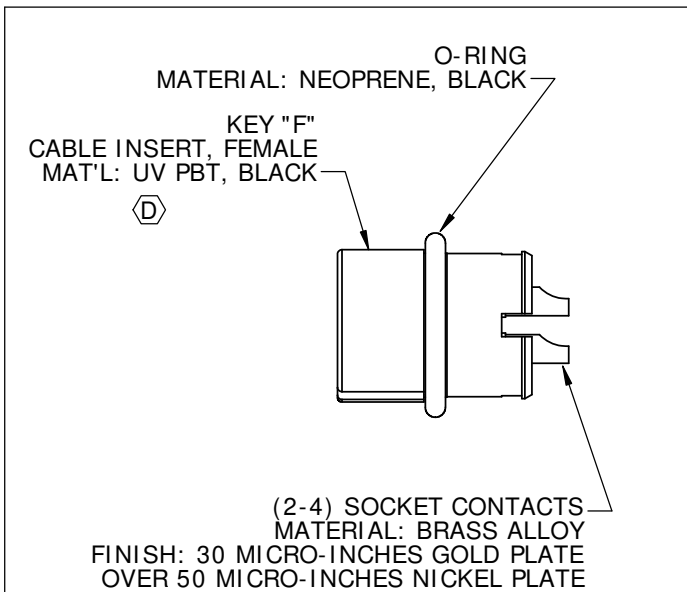

**HOUSING KIT**

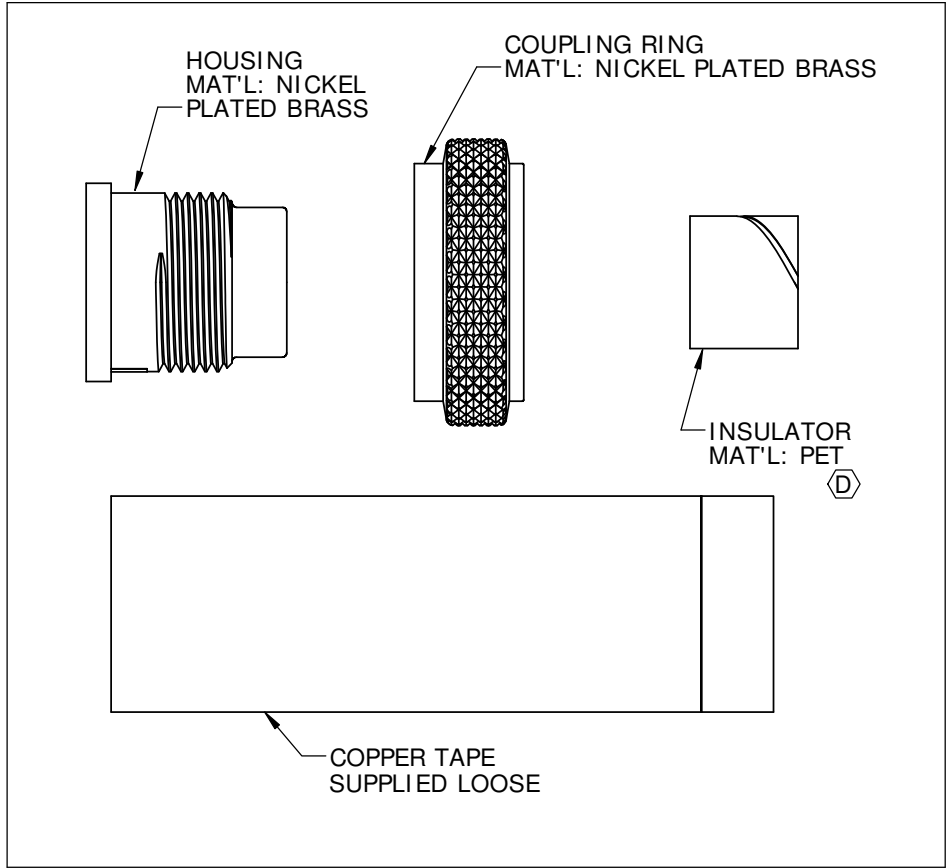

**BACKSHELL KIT**

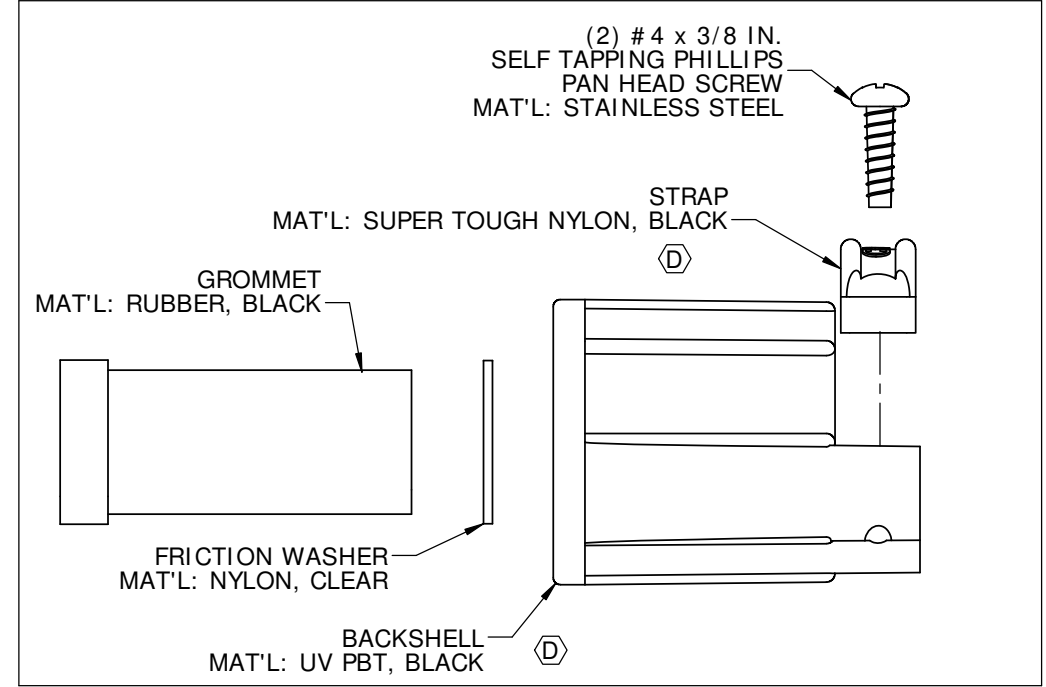

REV.	INIT.	DATE	DESCRIPTION
D	MA	10-08-19	SUPERSEDES DWG SF3382-XFSG-540. ADDED ASS'Y P/Ns SF3382-XSFG-520 & SF3382-XSFG-530 TO CHART. UPDATED MAT'LS ON SOME PIECE PARTS PER ECR 9439
C	MA	08-28-17	BAG LABEL WAS M-543 PER ECR 9013
B	PD	12-14-12	KITS WERE BULK PACKED PER ECR 8361, COPPER TAPE QTY. WAS 2 EACH PER ECR 8385
A	PD	10-23-12	DRAWING CREATED PER DOR 12-E149SL #32

ALL INFORMATION ILLUSTRATED IS THE PROPERTY OF CONXALL CORPORATION. UNAUTHORIZED DUPLICATION OR DISTRIBUTION OF THIS DOCUMENT IS PROHIBITED.	ORIG. DRAWN BY: PD DATE: 10-23-12	<p>601 E. WILDWOOD VILLA PARK, IL 60181</p>
ALL UNITS ARE IN FEET, INCHES, FRACTION OF INCHES AND DECIMALS.	CHECKED BY:	
APPROVED BY:	SCALE: NTS SIZE: B SHEET: 1 OF 1	TITLE: CONNECTOR ASSEMBLY KIT (2-4) SOCKET CONTACTS SHIELDED MULTI-CON-X STANDARD PRODUCT
FILE: SF3382-XFSG-5XX	DIRECTORY: SLW	CUSTOMER: SF3382-XFSG-5XX

RoHS COMPLIANT