

4

3

2

1

THIS DRAWING IS UNPUBLISHED. RELEASED FOR PUBLICATION
© COPYRIGHT ALL RIGHTS RESERVED.

LOC	DIST	REVISIONS			
P	LTR	DESCRIPTION	DATE	DWN	APVD
	A1	ECR-15-007476	19MAY2015	GK	HMR

REPLACED BY OCEAN STYLE APPLICATOR PART NUMBER 2266751-1

FOR REPLACEMENT PARTS FOR APPLICATOR 680706
REFER TO ADDITIONAL PAGE(S). SPARE PARTS KIT (IF LISTED)
WILL REMAIN AVAILABLE.

THE REPLACEMENT OCEAN STYLE APPLICATOR HAS THE
SAME TERMINATOR/PRESS INTERFACE AS APPLICATOR
680706

THIS DRAWING IS A CONTROLLED DOCUMENT.		DWN	GOPALAKRISHNA HV																				
DIMENSIONS:		CHK	RAGHAVENDRA																				
TOLERANCES UNLESS OTHERWISE SPECIFIED:		APVD	RAGHAVENDRA																				
<table border="0"> <tr><td>0</td><td>PLC</td><td>±</td></tr> <tr><td>1</td><td>PLC</td><td>±</td></tr> <tr><td>2</td><td>PLC</td><td>±</td></tr> <tr><td>3</td><td>PLC</td><td>±</td></tr> <tr><td>4</td><td>PLC</td><td>±</td></tr> <tr><td></td><td>ANGLES</td><td>±</td></tr> </table>		0	PLC	±	1	PLC	±	2	PLC	±	3	PLC	±	4	PLC	±		ANGLES	±	NAME	SIDE FEED HDM APPLICATOR		
0	PLC	±																					
1	PLC	±																					
2	PLC	±																					
3	PLC	±																					
4	PLC	±																					
	ANGLES	±																					
MATERIAL		PRODUCT SPEC																					
FINISH		APPLICATION SPEC																					
		WEIGHT	SIZE	CAGE CODE	DRAWING NO																		
			A3		©- 680706																		
		CUSTOMER DRAWING	SCALE	SHEET 1 OF 2	REV A1																		

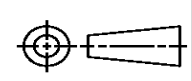

DRAWING MADE IN THIRD ANGLE PROJECTION

680706 680706

/home/amp04008/appl

PART NUMBER	REV	FIRST USED
680706-1	A	122500-1
680706-2	A	565435-5
680706-3	A	354500-1

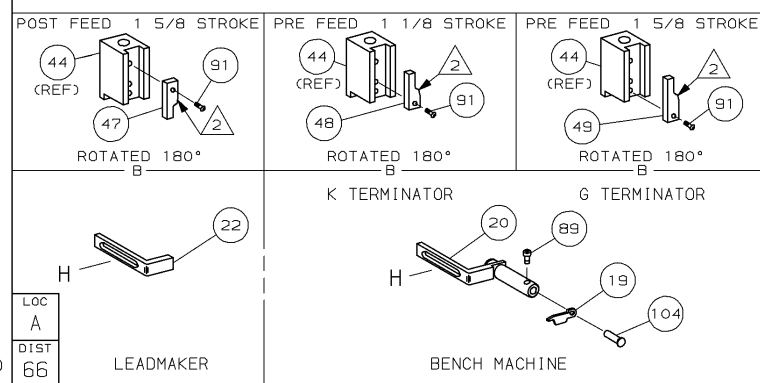
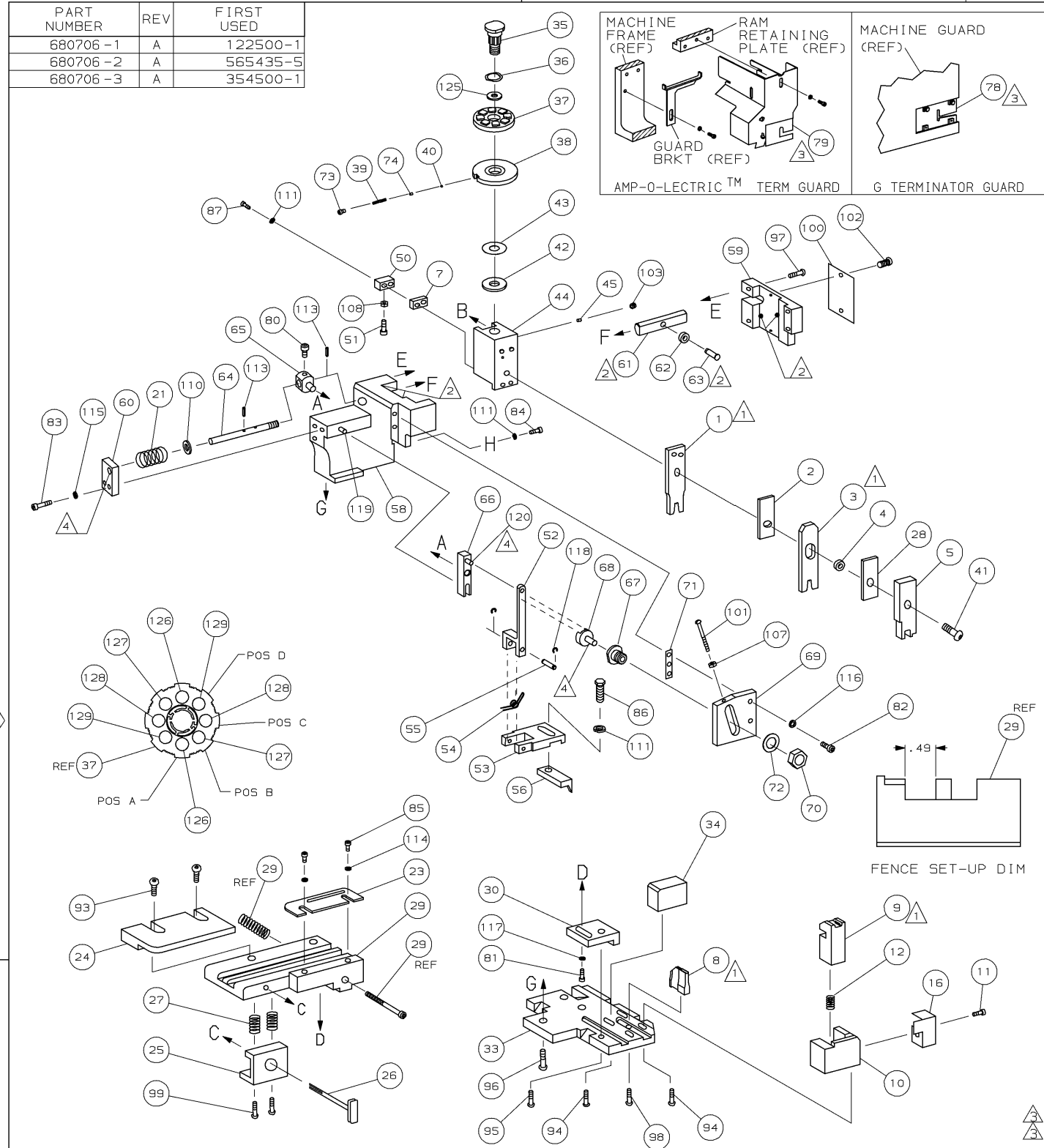

LOC A
DTST 66
LEADMAKER
BENCH MACHINE

- 1 RECOMMENDED SPARE PARTS.
- 2 GREASE LIGHTLY.
- 3 GUARD MUST BE IN PLACE WHEN OPERATING APPLICATOR IN A BENCH MACHINE.
- 4 LUBRICATE DAILY USING NO. 20 MACHINE OIL.
- 5. ITEMS WITH QTY OF REF SPECIFIED (EXCEPT ITEMS 78 AND 79) ARE USED ON ITEM 46.

TERMINAL NAME: C I II SOCKET									
CRIMP DATA (AMP TERMINAL)									
PAD LTR	CRIMP HEIGHT			WIRE SIZE					
A	.067 ±.002 [1.70 ±0.05mm]			2.50 mm ²					
B	.062 ±.002 [1.58 ±0.05mm]			2.00 mm ²					
C	.057 ±.002 [1.45 ±0.05mm]			1.50 mm ²					
D	.052 ±.002 [1.32 ±0.05mm]			1.00 mm ² OR 16					
CRIMP	SIZE	TYPE	RANGE						
WIRE	.110 [2.79mm]	F	1.00 mm ² -2.50 mm ²						
INSUL	.155 [3.94mm]	F	ø2.4-3mm ²						
WIRE STRIP LENGTH	TERM	APPL	SPEC	FEED	APPL INSTRUCTION	SET UP GAGE	LAYOUT		
.141-.171	NONE			.500	408-8040	458637-1	L2137		
2	2	2	-	C	2-354779-6	PIN, WIRE DISC (.3120)D	129		
2	2	2	-	C	1-354779-6	PIN, WIRE DISC (.3070)C	128		
2	2	2	-	C	354779-6	PIN, WIRE DISC (.3020)B	127		
2	2	2	-	C	9-354778-4	PIN, WIRE DISC (.2965)A	126		
1	1	1	-	A	986950-1	WASHER, FLAT PRECISION	125		
1	1	1	-	A	217238-1	GENERAL INSTRUCTION PACKAGE	124		
1	1	1	-	-	4088040	SF APPL INST 408-8040	123		
122									
121									
REF	REF	REF	-	A	1-21030-1	PIN, DOWEL (ø.187x.50) LEVER	120		
REF	REF	REF	-	A	1-21030-6	PIN, DOWEL (ø.187x1.25) HOUSING	119		
REF	REF	REF	-	A	21045-3	RING, RET "C" (ø.187) FD FING PIN	118		
1	1	1	-	A	21024-5	WASHER, LOCK (#10) ADJ BLOCK	117		
REF	REF	REF	-	A	21024-5	WASHER, LOCK (#10) ADJ PLATE	116		
REF	REF	REF	-	A	21024-5	WASHER, LOCK (#10) FEED GDE ROD	115		
2	2	2	-	A	21024-2	WASHER, LOCK (#4) FRONT STP GUIDE	114		
REF	REF	REF	-	A	5-21028-1	PIN, SLT SPR (ø.125x.50) ADJ ROD	113		
112									
4	4	4	-	A	21024-4	WASHER, LOCK (#8) STRIPPER	111		
REF	REF	REF	-	A	21899-4	WASHER, FLAT (ø5/16) SCREW ADJ	110		
109									
1	1	1	-	A	21018-5	NUT, HEX (NO. 6) HOLDDOWN	108		
REF	REF	REF	-	A	21068-5	NUT, HEX (6-32) FEED ADJ	107		
106									
105									
1	1	-	-	A	992031-1	PIN, CLEVIS	104		
1	1	1	-	A	21009-2	SCR, SKT SET (1/4-20x.25 LW) RAM	103		
2	2	2	-	A	21017-2	SCR, DRIVE (#2x.19) ID PLATE	102		
REF	REF	REF	-	A	6-23715-5	SCR, PAN HD (6-32x1.50) FEED ADJ	101		
1	1	1	-	B	461264-1	PLATE, IDENTIFICATION	100		
2	2	2	-	A	3-21002-0	SCR, BHC (10-32x.88) DRAG	99		
1	1	1	-	A	22733-8	SCR, BHC (8-32x.38 LW) ANVIL	98		
REF	REF	REF	-	A	2-21002-9	SCR, BHC (10-32x.75) CAP	97		
REF	REF	REF	-	A	2-22733-8	SCR, BHC (1/4-20x.62) HOUSING	96		
REF	REF	REF	-	A	2-21002-7	SCR, BHC (10-32x.50) 56 ADJ BLOCK	95		
4	4	4	-	A	2-21002-2	SCR, BHC (8-32x.50) TERM H DWN	94		
2	2	2	-	A	2-21002-1	SCR, BHC (8-32x.50) R STP GDE	93		
92									
1	1	1	-	A	1-21002-7	SCR, BHC (6-32x.38) CAM	91		
90									
1	1	-	-	A	7-21000-9	SCR, SHC (4-40x.19) STRIPPER	89		
88									
2	2	2	-	A	2-21000-8	SCR, SHC (8-32x.62) DEP-HOLD	87		
1	1	1	-	A	2-22603-0	SCR, HEX HD (8-32x.31) FEED FINGER	86		
2	2	2	-	A	1-21000-3	SCR, SHC (4-40x.25) F ST GUIDE	85		
1	1	1	-	A	2-21000-7	SCR, SHC (8-32x.50) STRIPPER	84		
REF	REF	REF	-	A	3-21000-7	SCR, SHC (10-32x.75) FEED ROD GD	83		
REF	REF	REF	-	A	3-21000-6	SCR, SHC (10-32x.62) FD ADJ BLK	82		
1	1	1	-	A	3-21000-4	SCR, SHC (10-32x.38) 56 ADJ BL	81		
REF	REF	REF	-	A	3-21000-4	SCR, SHC (10-32x.38) PIVOT BLK	80		
-	REF	-	-	B	455749-1	GUARD, WINDOW	79		
REF	-	-	-	B	679532-1	INSERT, GUARD	78		
77									
76									
75									
1	1	1	-	A	690603-1	SPRING, ASSIST	74		
1	1	1	-	A	23030-1	SCR, SHC (6-32x.25 SL) INS DISC	73		
REF	REF	REF	-	A	458109-1	WASHER, SPECIAL	72		
REF	REF	REF	-	A	690517-1	SPACER	71		
-3	-2	-1	U/M	DWG SIZE	PART NO	DESCRIPTION	ITEM NO		
QTY REQD PER ASSY					PARTS LIST				

LEADMAKER		MECH POST FEED							
REF	REF	REF	REF	REF	REF				
-1	BENCH MODEL K	MECH PRE FEED							
-2	BENCH MODEL G	MECH PRE FEED							
-3	BENCH MODEL G	MECH PRE FEED							
REF	REF	REF	-	B	22594-8	NUT, HEX (1/2-20)	70		
REF	REF	REF	-	B	240628-1	PLATE, ADJUSTMENT	69		
REF	REF	REF	-	B	240626-1	SHAFT, PIVOT	68		
REF	REF	REF	-	B	240633-1	BUSHING	67		
REF	REF	REF	-	A	455680-1	LEVER, INTERMEDIATE	66		
REF	REF	REF	-	B	240629-1	BLOCK, PIVOT	65		
REF	REF	REF	-	A	240632-2	SCREW, ADJ FEED ROD	64		
REF	REF	REF	-	B	240659-3	PIN, CAM ROLLER	63		
REF	REF	REF	-	B	240658-1	ROLLER, CAM	62		
REF	REF	REF	-	B	454398-2	ROD, FEED	61		
REF	REF	REF	-	A	454178-1	GUIDE, FEED ROD	60		
REF	REF	REF	-	C	454220-1	CAP, RAM	59		
REF	REF	REF	-	D	454485-1	HOUSING	58		
						57			
1	1	1	-	B	690542-2	PAWL, FEED	56		
REF	REF	REF	-	B	240624-1	PIN, FEED FINGER	55		
REF	REF	REF	-	B	691499-1	SPRING, FEED FINGER	54		
REF	REF	REF	-	B	690541-1	HOLDER, FEED FINGER	53		
REF	REF	REF	-	A	455679-1	LEVER, TERMINAL FEED ARM	52		
1	1	1	-	A	811242-2	BUMPER, HOLDDOWN	51		
1	1	1	-	A	690753-1	SPACER, TONKER	50		
1	-	-	-	B	690602-6	CAM, PRE-FEED 1 5/8 ST	49		
-	1	-	-	B	690602-5	CAM, PRE-FEED 1 1/8 ST	48		
-	-	1	-	B	690501-4	CAM, POST-FEED 1 5/8 ST	47		
1	1	1	-	B	459456-1	APPLICATOR, BASIC (SUBASSY)	46		
1	1	1	-	A	690191-1	PLUG, NYLON	45		
1	1	1	-	C	455673-1	RAM	44		
1	1	1	-	A	690125-1	WASHER, LAMINATED	43		
1	1	1	-	A	690124-1	WASHER, RAM	42		
1	1	1	-	A	7-21002-9	BOLT, CRIMPER (5/16x1.00)	41		
1	1	1	-	A	23241-6	BALL, STEEL	40		
1	1	1	-	A	690170-1	SPRING, COMPRESSION	39		
1	1	1	-	C	1-690142-0	DISC, INSULATION	38		
1	1	1	-	D	354777-1	WIRE DISC, PLASTIC	37		
1	1	1	-	A	22480-5	WASHER, SPRING	36		
1	1	1	-	B	690212-1	POST, RAM	35		
1	1	1	-	B	1-690786-2	SUPPORT, TERMINAL	34		
REF	REF	REF	-	D	455675-1	PLATE, BASE	33		
						32			
						31			
REF	REF	REF	-	B	455689-1	BLOCK, STRIP GUIDE ADJ	30		
1	1	1	-	C	318042-1	STRIP GUIDE PLATE ASSY	29		
1	1	1	-	C	1-455888-6	SPACER, FRONT SHEAR DEP	28		
2	2	2	-	A	1-22284-0	SPRING, DRAG	27		
1	1	1	-	B	690546-1	LEVER, DRAG RELEASE	26		
1	1	1	-	B	240792-1	DRAG, TERMINAL	25		
1	1	1	-	D	6-690504-2	GUIDE, STRIP (REAR)	24		
1	1	1	-	A	690438-1	GUIDE, STRIP (FRONT)	23		
-	-	1	-	B	690472-2	STRIPPER	22		
REF	REF	REF	-	A	4-22284-9	SPRING, FEED RETURN	21		
1	1	-	-	A	679218-1	STRIPPER WIRE STOP ASSY	20		
1	1	-	-	B	458949-1	STRIPPER	19		
						18			
						17			
1	1	1	-	B	318563-1	GUARD, CHIP, FRONT	16		
						15			
						14			
						13			
1	1	1	-	A	5-22280-0	SPRING, SHEAR	12		
1	1	1	-	B	690461-1	STOP, SHEAR	11		
1	1	1	-	C	690459-1	HOLDER, SHEAR (FRONT)	10		
1	1	1	-	C	454276-1	SHEAR, FLOAT (FRONT)	9		
1	1	1	-	C	1-662189-0	ANVIL	8		
1	1	1	-	C	240641-5	SPACER, DEPRESSOR (REAR)	7		
						6			
1	1	1	-	C	1-455889-4	DEPRESSOR, SHEAR (FRONT)	5		
1	1	1	-	B	2-238011-2	SPACER, BLOCK CRIMPER	4		
1	1	1	-	C	683453-3	CRIMPER, INSULATION	3		
1	1	1	-	C	455888-4	SPACER, CRIMPER	2		
1	1	1	-	C	4-456408-0	CRIMPER, WIRE	1		
-3	-2	-1	U/M	DWG SIZE	PART NO	DESCRIPTION	ITEM NO		
QTY REQD PER ASSY					PARTS LIST				

AMP 1758 REV 3-92 24-NOV-98 08:56:00 amp04008 7 6 5 4 3