

4

3

2

1

THIS DRAWING IS UNPUBLISHED. RELEASED FOR PUBLICATION
 © COPYRIGHT ALL RIGHTS RESERVED.

LOC		DIST		REVISIONS		
P	LTR	DESCRIPTION	DATE	DWN	APVD	
	A2	ECR-14-002339	08APR2014	GK	HMR	

REPLACED BY OCEAN STYLE APPLICATOR PART NUMBER 2151634-6

FOR REPLACEMENT PARTS FOR APPLICATOR 1911098
 REFER TO ADDITIONAL PAGE(S). SPARE PARTS KIT (IF LISTED)
 WILL REMAIN AVAILABLE.

THE REPLACEMENT OCEAN STYLE APPLICATOR HAS THE
 SAME TERMINATOR/PRESS INTERFACE AS APPLICATOR
 1911098

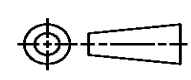
THIS DRAWING IS A CONTROLLED DOCUMENT.		DWN	GOPALAKRISHNA HV		 TE Connectivity	
DIMENSIONS:		CHK	RAGHAVENDRA			
		APVD	RAGHAVENDRA		NAME SIDE FEED SYSTEM III APPLICATOR	
TOLERANCES UNLESS OTHERWISE SPECIFIED: 0 PLC ± 1 PLC ± 2 PLC ± 3 PLC ± 4 PLC ± ANGLES ±		PRODUCT SPEC				
MATERIAL	FINISH	APPLICATION SPEC	SIZE	CAGE CODE	DRAWING NO	RESTRICTED TO
		WEIGHT	A3		©- 1911098	
CUSTOMER DRAWING			SCALE	SHEET 1 OF 2	REV A2	

PART NUMBER	REV	DESCRIPTION	PROGRAMMED MEMORY CHIP
1911098-1	A	CUTS CARRIER	8-1911098-1
1911098-6	A	CONTINUOUS CARRIER	8-1911098-6
7-1911098-1	A	-1 AND SPARE PARTS	9-1911098-1
7-1911098-6	A	-6 AND SPARE PARTS	9-1911098-6
7-1911098-7	A	SPARE PARTS KIT	-

APPLICATOR DATA		
CRIMP	SIZE	TYPE
WIRE	.120 [3.05mm]	F
INSUL	.160 [4.06mm]	OV
APPL INSTRUCTIONS 408-10135		

TERMINAL DATA: TE TERMINAL TYCO ELECTRONICS CRIMP SPEC	
TERMINAL NAME: AMP MCP2.8 FLAT TYPE RECEPTACLE	
WIRE STRIP LENGTH 5.3-5.9 mm [1.208-.232 IN]	INSULATION DIAMETER RANGE 2.70-3.70mm [1.06-.145 IN]
TERMINAL APPL SPEC 114-18148	
TERMINALS APPLIED	
1-968853-1	1-968853-3

WIRE SIZE	CRIMP HEIGHT
4mm ²	2.27±.05 [1.089±.002]

FEED FINGER 1901694-1
SET UP GAGE 1901040-1
LOC A DIST 66

REVISIONS				
REV	DATE	DESCRIPTION	BY	APPV
A	24JUL2007	RELEASED	DWW	GD
A1	25SEP2007	ADDED 2 BOTTOM VIEWS	DWW	NED

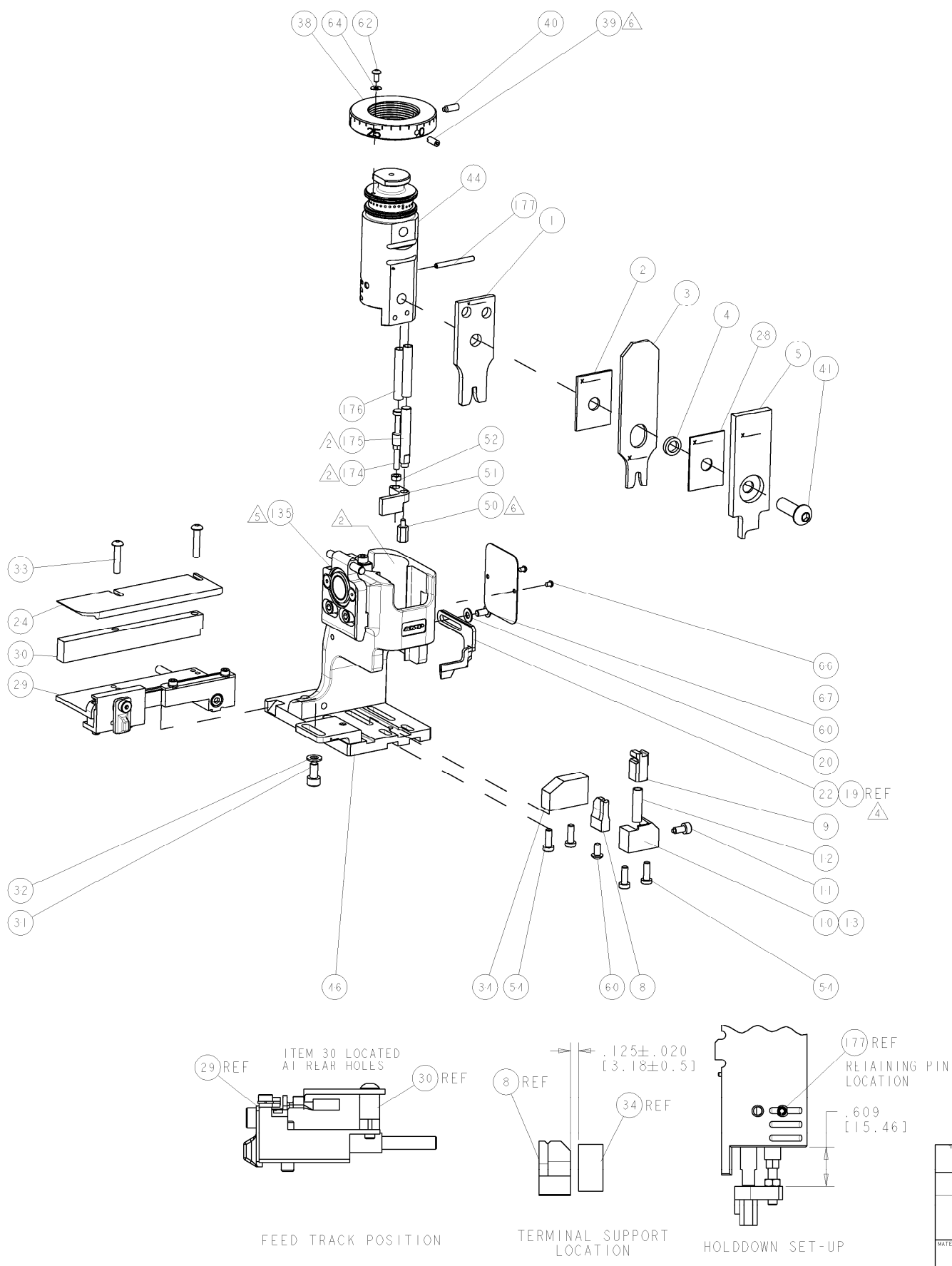

- ⚠ RECOMMENDED SPARE PARTS.
- ⚠ GREASE BEARING SURFACES LIGHTLY.
- 3. LUBRICATE DAILY PER THE APPLICATOR INSTRUCTION SHEET SUPPLIED WITH THE APPLICATOR.
- ⚠ ITEM 19 - OPTIONAL STRIPPER FOR BENCH MACHINE APPLICATIONS.
- ⚠ APPLICATOR SPECIFIC DATA TO BE ENTERED INTO BLANK MEMORY CHIP AT ASSEMBLY.
- ⚠ APPLY P/N 1-23419-5 LOCTITE(R) TO THREADS.

QTY	REF	REF	REF	REF	PART NO	DESCRIPTION	ITEM NO
-	1	1	1	1	1-993111-6	PIN, SLOTTED SPRING 3.0 X 30.0	177
-	2	2	2	2	3-22280-7	SPRING, COMPRESSION	176
-	1	1	1	1	1752353-1	GUIDE PIN, HOLDDOWN	175
-	1	1	1	1	1901680-1	GUIDE PIN, HOLDDOWN	174
-	REF	REF	REF	REF	SEE TABLE	MEMORY CHIP, PROGRAMMED	135
-	1	1	1	1	1633565-1	DOCUMENTATION PACKAGE	71
-	1	1	1	1	1901048-1	TAG, IDENTIFICATION	67
-	2	2	2	2	21017-1	SCREW, DRIVE	66
-	1	1	1	1	18028-1	WASHER, FLAT, REG M3	64
-	1	1	1	1	1655785-9	SCR, BTN SKT HD CAP (M3 X 6)	62
-	2	2	2	2	1655785-1	SCR, BTN SKT HD CAP (M4 X 8)	60
-	4	4	4	4	1655783-3	SCR, CAP, SOC HD, LOW HEAD, M4 X 12	54
-	1	1	1	1	1-18030-0	NUT, HEX, REG M3.5	52
-	1	1	1	1	1901681-1	HOLDDOWN, TERMINAL	51
-	1	1	1	1	2-1752354-5	STANDOFF, HOLD-DOWN	50
-	1	1	1	1	1752300-1	SF SYSTEM III APPLICATOR	46
-	1	1	1	1	1752308-1	RAM	44
-	1	1	1	1	2-1655785-3	SCR, BTN SKT HD CAP (M8 X 25)	41
-	1	1	1	1	993002-4	SCREW, SET, SFT TIP	40
-	1	1	1	1	1962043-1	PLUNGER, BALL, METRIC	39
-	1	1	1	1	1752309-3	RING, INSULATION CRIMP	38
-	1	1	1	1	1-1752356-7	SUPPORT, TERMINAL	34
-	2	2	2	2	3-1655785-3	SCR, BTN SKT HD CAP (M4 X 20)	33
-	1	1	1	1	18028-3	WASHER, FLAT, REG M5	32
-	1	1	1	1	5-1655316-3	SCR, SKT HD CAP, M5 X 10.0	31
-	1	1	1	1	1320908-3	SPACER, STRIP GUIDE	30
-	1	1	1	1	1901087-3	ASSEMBLY, STRIP GUIDE	29
-	1	1	1	1	455888-8	SPACER, CRIMPER	28
-	1	1	1	1	1320928-1	PLATE, STRIP GUIDE	24
-	1	1	1	1	1976045-1	STRIPPER	22
-	1	1	1	1	18028-2	WASHER, FLAT, REG M4	20
-	REF	REF	REF	REF	1752311-1	STRIPPER	19
-	1	1	1	1	1338684-1	SHEAR HOLDER, FRONT	13
-	1	1	1	1	3-22280-3	SPRING, COMPRESSION	12
-	1	1	1	1	356885-4	STOP, SHEAR	11
-	1	1	1	1	1320921-1	SHEAR HOLDER, FRONT, CUT	10
-	1	1	1	1	454276-1	FLOATING SHEAR, FRONT	9
-	1	2	2	1	1333208-7	ANVIL, COMBINATION	8
-	1	1	1	1	3-455889-6	DEPRESSOR, SHEAR	5
-	1	1	1	1	238011-4	BLOCK, CRIMPER SPACER	4
-	1	2	2	1	4-655621-7	OVERLAPPING CRIMPER, INSUL HD TYP	3
-	1	1	1	1	1-455888-5	SPACER, CRIMPER	2
-	1	2	2	1	456409-3	CRIMPER, WIRE .120 "F" PREMIUM	1

DIMENSIONS:		TOLERANCES UNLESS OTHERWISE SPECIFIED:		DWG		CHK		APPV	
INCHES	(mm)	0 PLC	±	D. WRIGHT	26 JUN 2007	N. DEMING	26 JUN 2007	N. DEMING	26 JUN 2007
MATERIAL:				FINISH:		APPLICATION SPEC:		SEE TABLE	
CUSTOMER DRAWING				SCALE: 3:5		SHEET 1 OF 1		REV A	