



## CAN TRANSCEIVER

### FEATURES

- Qualified for Automotive Applications
- Drop-In Improved Replacement for the PCA82C250 and PCA82C251
- Bus-Fault Protection of  $\pm 36$  V
- Meets or Exceeds ISO 11898
- Signaling Rates<sup>(1)</sup> up to 1 Mbps
- High Input Impedance Allows up to 120 SN65HVD251 Nodes on a Bus
- Bus Pins ESD Protection Exceeds 9 kV (HBM)
- Unpowered Node Does Not Disturb the Bus
- Low-Current Standby Mode: 200  $\mu$ A Typical
- Thermal Shutdown Protection
- Glitch-Free Power-Up and Power-Down Bus Protection for Hot Plugging
- DeviceNet™ Vendor ID #806

<sup>(1)</sup> The signaling rate of a line is the number of voltage transitions that are made per second expressed in bps (bits per second).

### APPLICATIONS

- CAN Data Buses
- Industrial Automation
  - DeviceNet Data Buses
  - Smart Distributed Systems (SDS™)
- SAE J1939 Standard Data Bus Interface
- NMEA 2000 Standard Data Bus Interface
- ISO 11783 Standard Data Bus Interface

### DESCRIPTION

The SN65HVD251 is intended for use in applications employing the Controller Area Network (CAN) serial communication physical layer in accordance with the ISO 11898 Standard. The SN65HVD251 provides differential transmit capability to the bus and differential receive capability to a CAN controller at speeds up to 1 megabit per second (Mbps).

Designed for operation in harsh environments, the device features crosswire, overvoltage, and loss of ground protection to  $\pm 36$  V. Also featured are overtemperature protection as well as  $-7$ -V to 12-V common-mode range, and tolerance to transients of  $\pm 200$  V. The transceiver interfaces the single-ended CAN controller with the differential CAN bus found in industrial, building automation, and automotive applications.

Rs, pin 8, selects one of three different modes of operation: high-speed, slope control, or low-power mode. The high-speed mode of operation is selected by connecting pin 8 to ground, allowing the transmitter output transistors to switch as fast as possible with no limitation on the rise and fall slope. The rise and fall slope can be adjusted by connecting a resistor to ground at pin 8; the slope is proportional to the pin's output current. Slope control with an external resistor value of 10 k $\Omega$  gives  $\sim 15$  V/ $\mu$ s slew rate; 100 k $\Omega$  gives  $\sim 2$  V/ $\mu$ s slew rate.

If a high logic level is applied to the Rs pin 8, the device enters a low-current standby mode where the driver is switched off and the receiver remains active. The local protocol controller returns the device to the normal mode when it transmits to the bus.

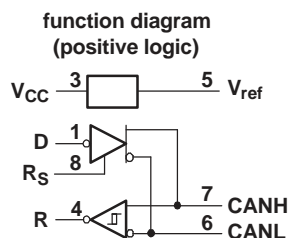
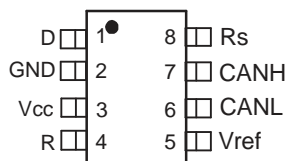

Please be aware that an important notice concerning availability, standard warranty, and use in critical applications of Texas Instruments semiconductor products and disclaimers thereto appears at the end of this data sheet.

All trademarks are the property of their respective owners.



These devices have limited built-in ESD protection. The leads should be shorted together or the device placed in conductive foam during storage or handling to prevent electrostatic damage to the MOS gates.

### ORDERING INFORMATION<sup>(1)</sup>

PART NUMBER	PACKAGE	MARKED AS
SN65HVD251QDRQ1	8-pin SOIC (Tape and Reel)	251Q1

(1) For the most current package and ordering information, see the Package Option Addendum at the end of this document, or see the TI web site at [www.ti.com](http://www.ti.com).

### ABSOLUTE MAXIMUM RATINGS

over operating free-air temperature range (unless otherwise noted)<sup>(1)(2)</sup>

			SN65HVD251
Supply voltage range, $V_{CC}$			–0.3 V to 7 V
Voltage range at any bus terminal		CANH, CANL	–36 V to 36 V
Transient voltage per ISO 7637, pulse 1, 2, 3a, 3b		CANH, CANL	±200 V
Input voltage range, $V_I$		D, Rs, R	–0.3 V to $V_{CC} + 0.5$
Receiver output current, $I_O$			–10 mA to 10 mA
Electrostatic discharge	Human-Body Model <sup>(3)</sup>	CANH, CANL, GND	9 kV
		All pins	6 kV
	Charged-Device Model <sup>(4)</sup>	All pins	1 kV
		Machine Model	All pins
Continuous total power dissipation			See Dissipation Rating Table

- (1) Stresses beyond those listed under "absolute maximum ratings" may cause permanent damage to the device. These are stress ratings only and functional operation of the device at these or any other conditions beyond those indicated under "recommended operating conditions" is not implied. Exposure to absolute-maximum-rated conditions for extended periods may affect device reliability.
- (2) All voltage values, except differential I/O bus voltages, are with respect to network ground terminal.
- (3) Tested in accordance with JEDEC Standard 22, Test Method A114-A
- (4) Tested in accordance with JEDEC Standard 22, Test Method C101

### ABSOLUTE MAXIMUM POWER DISSIPATION RATINGS

PACKAGE	CIRCUIT BOARD MODEL	$T_A = 25^\circ\text{C}$ POWER RATING	DERATING FACTOR <sup>(1)</sup> ABOVE $T_A = 25^\circ\text{C}$	$T_A = 85^\circ\text{C}$ POWER RATING	$T_A = 125^\circ\text{C}$ POWER RATING
SOIC (D)	Low-K <sup>(2)</sup>	576 mW	4.8 mW/°C	288 mW	96 mW
	High-K <sup>(3)</sup>	924 mW	7.7 mW/°C	462 mW	154 mW

- (1) This is the inverse of the junction-to-ambient thermal resistance when board-mounted and with no air flow.
- (2) In accordance with the Low-K thermal metric definitions of EIA/JESD51-3
- (3) In accordance with the High-K thermal metric definitions of EIA/JESD51-7

## THERMAL CHARACTERISTICS

PARAMETER	TEST CONDITIONS	VALUE			UNIT
		MIN	TYP	MAX	
$\theta_{JB}$ Junction-to-board thermal resistance			78.7		°C/W
$\theta_{JC}$ Junction-to-case thermal resistance			44.6		°C/W
$P_D$ Device power dissipation	$V_{CC} = 5\text{ V}$ , $T_J = 27^\circ\text{C}$ , $R_L = 60\ \Omega$ , $R_S$ at 0 V, Input to D a 500-kHz 50% duty cycle square wave			97.7	mW
	$V_{CC} = 5.5\text{ V}$ , $T_J = 130^\circ\text{C}$ , $R_L = 60\ \Omega$ , $R_S$ at 0 V, Input to D a 500-kHz 50% duty cycle square wave			142	mW
$T_{SD}$ Thermal shutdown junction temperature			165		°C

## RECOMMENDED OPERATING CONDITIONS

over recommended operating conditions (unless otherwise noted)

PARAMETER		MIN	NOM	MAX	UNIT
Supply voltage, $V_{CC}$		4.5		5.5	V
Voltage at any bus terminal (separately or common mode) $V_I$ or $V_{IC}$		$-7^{(1)}$		12	V
High-level input voltage, $V_{IH}$	D input	$0.7 V_{CC}$			V
Low-level input voltage, $V_{IL}$	D input			$0.3 V_{CC}$	V
Differential input voltage, $V_{ID}$		-6		6	V
Input voltage to $R_S$ , $V_{I(R_S)}$		0		$V_{CC}$	V
Input voltage at $R_S$ for standby, $V_{I(R_S)}$		$0.75 V_{CC}$		$V_{CC}$	V
$R_S$ wave-shaping resistance		0		100	k $\Omega$
High-level output current, $I_{OH}$	Driver	-50			mA
	Receiver	-4			
Low-level output current, $I_{OL}$	Driver			50	mA
	Receiver			4	
Operating free-air temperature, $T_A$		-40		125	°C
Junction temperature, $T_j$				145	°C

(1) The algebraic convention, in which the least positive (most negative) limit is designated as minimum is used in this data sheet.

## DRIVER ELECTRICAL CHARACTERISTICS

over recommended operating conditions (unless otherwise noted)

PARAMETER		TEST CONDITIONS	MIN	TYP <sup>(1)</sup>	MAX	UNIT	
V <sub>OD(D)</sub>	Bus output voltage (Dominant)	CANH	Figure 1 and Figure 2, D at 0 V, Rs at 0 V	2.75	3.5	4.5	V
		CANL		0.5		2	
V <sub>OD(R)</sub>	Bus output voltage (Recessive)	CANH	Figure 1 and Figure 2, D at 0.7 V <sub>CC</sub> , Rs at 0 V	2	2.5	3	
		CANL		2	2.5	3	
V <sub>OD(D)</sub>	Differential output voltage (Dominant)	Figure 1, D at 0 V, Rs at 0 V	1.5	2	3	V	
V <sub>OD(D)</sub>	Differential output voltage (Dominant)	Figure 2 and Figure 3, D at 0 V, Rs at 0 V	1.2	2	3.1	V	
V <sub>OD(R)</sub>	Differential output voltage (Recessive)	Figure 1 and Figure 2, D at 0.7 V <sub>CC</sub>	–120		12	mV	
V <sub>OD(R)</sub>	Differential output voltage (Recessive)	D at 0.7 V <sub>CC</sub> , No load	–0.5		0.05	V	
V <sub>OC(pp)</sub>	Peak-to-peak common-mode output voltage	Figure 9, Rs at 0 V		600		mV	
I <sub>IH</sub>	High-level input current, D input	D at 0.7 V <sub>CC</sub>	–40		0	μA	
I <sub>IL</sub>	Low-level input current, D input	D at 0.3 V <sub>CC</sub>	–60		0	μA	
I <sub>OS(SS)</sub>	Short-circuit steady-state output current	Figure 11, V <sub>CANH</sub> at –7 V, CANL open	–200			mA	
		Figure 11, V <sub>CANH</sub> at 12 V, CANL open			2.5		
		Figure 11, V <sub>CANL</sub> at –7 V, CANH open	–2				
		Figure 11, V <sub>CANL</sub> at 12 V, CANH open			200		
C <sub>O</sub>	Output capacitance	See receiver input capacitance					
I <sub>OZ</sub>	High-impedance output current	See receiver input current					
I <sub>IRs(s)</sub>	Rs input current for standby	Rs at 0.75 V <sub>CC</sub>	–10			μA	
I <sub>IRs(f)</sub>	Rs input current for full-speed operation	Rs at 0 V	–550		0	μA	
I <sub>CC</sub>	Supply current	Standby	Rs at V <sub>CC</sub> , D at V <sub>CC</sub>		275	μA	
		Dominant	D at 0 V, 60-Ω load, Rs at 0 V		65	mA	
		Recessive	D at V <sub>CC</sub> , No load, Rs at 0 V		14		

(1) All typical values are at 25°C and with a 5-V supply.

## DRIVER SWITCHING CHARACTERISTICS

over recommended operating conditions (unless otherwise noted)

PARAMETER		TEST CONDITIONS	MIN	TYP	MAX	UNIT
t <sub>pLH</sub>	Propagation delay time, low-to-high-level output	Figure 4, Rs at 0 V		40	70	ns
		Figure 4, Rs with 10 kΩ to ground		90	125	
		Figure 4, Rs with 100 kΩ to ground		500	800	
t <sub>pHL</sub>	Propagation delay time, high-to-low-level output	Figure 4, Rs at 0 V		85	125	ns
		Figure 4, Rs with 10 kΩ to ground		200	260	
		Figure 4, Rs with 100 kΩ to ground		1150	1450	
t <sub>sk(p)</sub>	Pulse skew ((t <sub>pHL</sub> – t <sub>pLH</sub> ))	Figure 4, Rs at 0 V		45	85	ns
		Figure 4, Rs with 10 kΩ to ground		110	180	
		Figure 4, Rs with 100 kΩ to ground		650	900	
t <sub>r</sub>	Differential output signal rise time	Figure 4, Rs at 0 V	35		100	ns
t <sub>f</sub>	Differential output signal fall time		35		100	ns
t <sub>r</sub>	Differential output signal rise time	Figure 4, Rs with 10 kΩ to ground	100		250	ns
t <sub>f</sub>	Differential output signal fall time		100		250	ns
t <sub>r</sub>	Differential output signal rise time	Figure 4, Rs with 100 kΩ to ground	600		1550	ns
t <sub>f</sub>	Differential output signal fall time		600		1550	ns
t <sub>en</sub>	Enable time from standby to dominant	Figure 8		0.5		μs

## RECEIVER ELECTRICAL CHARACTERISTICS

over recommended operating conditions (unless otherwise noted)

PARAMETER		TEST CONDITIONS	MIN	TYP	MAX	UNIT
$V_{IT+}$	Positive-going input threshold voltage	$R_s$ at 0 V, (See <a href="#">Table 1</a> )		750	900	mV
$V_{IT-}$	Negative-going input threshold voltage			500	650	
$V_{hys}$	Hysteresis voltage ( $V_{IT+} - V_{IT-}$ )			100		
$V_{OH}$	High-level output voltage	<a href="#">Figure 6</a> , $I_O = -4$ mA	0.8 $V_{CC}$			V
$V_{OL}$	Low-level output voltage	<a href="#">Figure 6</a> , $I_O = 4$ mA			0.2 $V_{CC}$	V
$I_I$	Bus input current	CANH or CANL at 12 V			600	A
		CANH or CANL at 12 V, $V_{CC}$ at 0 V			715	
		CANH or CANL at -7 V	Other bus pin at 0 V, $R_s$ at 0 V, D at 0.7 $V_{CC}$		-460	
		CANH or CANL at -7 V, $V_{CC}$ at 0 V			-340	
$C_I$	Input capacitance (CANH or CANL)	Pin-to-ground, $V_I = 0.4 \sin(4E6\pi t) + 0.5$ V, D at 0.7 $V_{CC}$	20			pF
$C_{ID}$	Differential input capacitance	Pin-to-pin, $V_I = 0.4 \sin(4E6\pi t) + 0.5$ V, D at 0.7 $V_{CC}$	10			pF
$R_{ID}$	Differential input resistance	D at 0.7 $V_{CC}$ , $R_s$ at 0 V	40		100	k $\Omega$
$R_{IN}$	Input resistance (CANH or CANL)	D at 0.7 $V_{CC}$ , $R_s$ at 0 V	20		50	k $\Omega$
$I_{CC}$	Supply current	Standby	$R_s$ at $V_{CC}$ , D at $V_{CC}$		275	mA
		Dominant	D at 0 V, 60- $\Omega$ load, $R_s$ at 0 V		65	
		Recessive	D at $V_{CC}$ , No load, $R_s$ at 0 V		14	

## RECEIVER SWITCHING CHARACTERISTICS

over recommended operating conditions (unless otherwise noted)

PARAMETER		TEST CONDITIONS	MIN	TYP	MAX	UNIT
$t_{pLH}$	Propagation delay time, low-to-high-level output	<a href="#">Figure 6</a>		35	50	ns
$t_{pHL}$	Propagation delay time, high-to-low-level output			35	50	ns
$t_{sk(p)}$	Pulse skew ( $t_{pHL} - t_{pLH}$ )				20	ns
$t_r$	Output signal rise time			2	4	ns
$t_f$	Output signal fall time			2	4	ns
$t_{p(sb)}$	Propagation delay time in standby		<a href="#">Figure 12</a> , $R_s$ at $V_{CC}$			500

## VREF PIN CHARACTERISTICS

over recommended operating conditions (unless otherwise noted)

PARAMETER		TEST CONDITIONS	MIN	MAX	UNIT
$V_O$	Reference output voltage	$-5 \mu A < I_O < 5 \mu A$	0.45 $V_{CC}$	0.55 $V_{CC}$	V
		$-50 \mu A < I_O < 50 \mu A$	0.4 $V_{CC}$	0.6 $V_{CC}$	

**DEVICE SWITCHING CHARACTERISTICS**

over recommended operating conditions (unless otherwise noted)

PARAMETER		TEST CONDITIONS	MIN	TYP	MAX	UNIT
$t_{loop1}$	Total loop delay, driver input to receiver output, recessive to dominant	Figure 10, Rs at 0 V		60	100	ns
		Figure 10, Rs with 10 k $\Omega$ to ground		100	150	
		Figure 10, Rs with 100 k $\Omega$ to ground		440	800	
$t_{loop2}$	Total loop delay, driver input to receiver output, dominant to recessive	Figure 10, Rs at 0 V		115	150	ns
		Figure 10, Rs with 10 k $\Omega$ to ground		235	290	
		Figure 10, Rs with 100 k $\Omega$ to ground		1070	1450	
$t_{loop2}$	Total loop delay, driver input to receiver output, dominant to recessive	Figure 10, Rs at 0 V, $V_{CC}$ from 4.5 V to 5.1 V		105	145	ns

PARAMETER MEASUREMENT INFORMATION

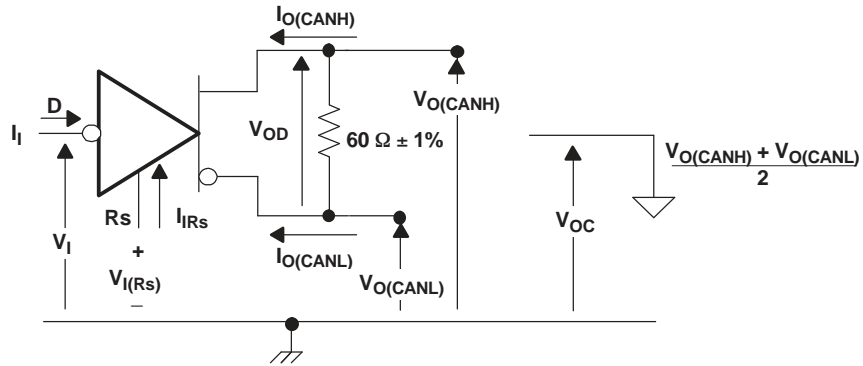

Figure 1. Driver Voltage, Current, and Test Definition

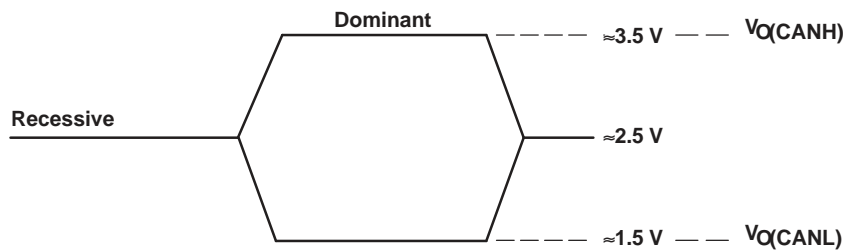

Figure 2. Bus Logic State Voltage Definitions

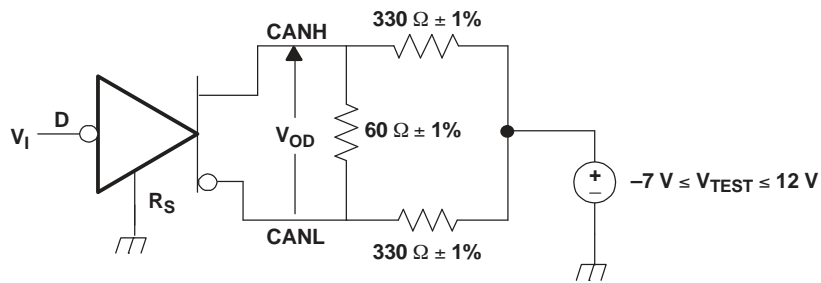

Figure 3. Driver  $V_{OD}$

PARAMETER MEASUREMENT INFORMATION (continued)

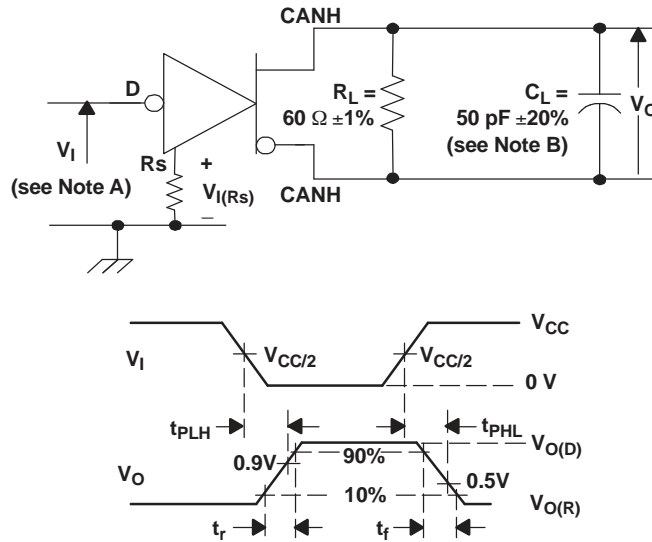

Figure 4. Driver Test Circuit and Voltage Waveforms

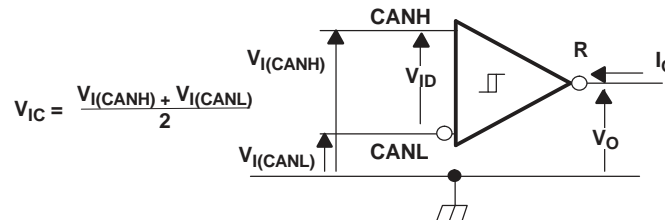
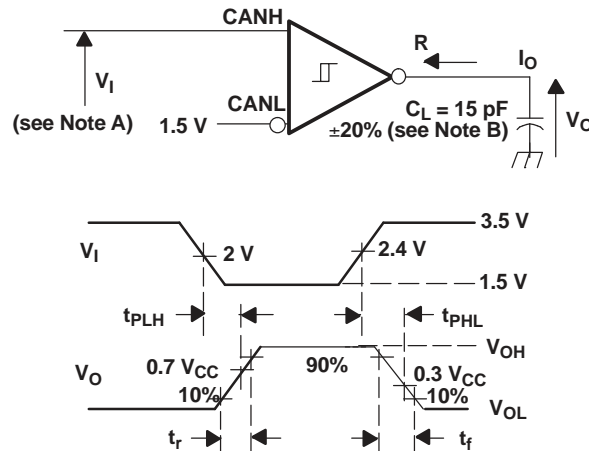

Figure 5. Receiver Voltage and Current Definitions



- A. The input pulse is supplied by a generator having the following characteristics: PRR ≤ 125 kHz, 50% duty cycle, t<sub>r</sub> ≤ 6ns, t<sub>f</sub> ≤ 6 ns, Z<sub>O</sub> = 50 Ω.
- B. C<sub>L</sub> includes instrumentation and fixture capacitance within ±20%.

Figure 6. Receiver Test Circuit and Voltage Waveforms



PARAMETER MEASUREMENT INFORMATION (continued)

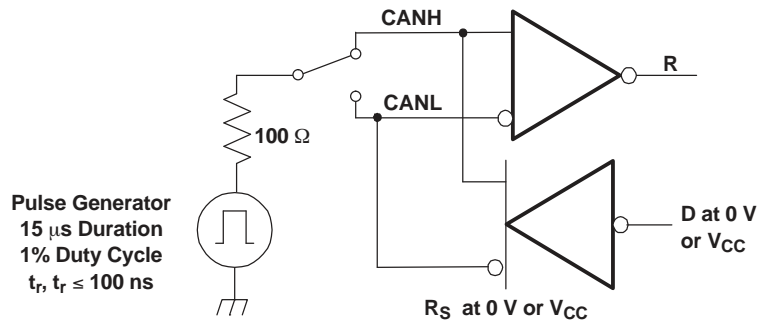

A. This test is conducted to test survivability only. Data stability at the R output is not specified.

Figure 7. Test Circuit, Transient Overvoltage Test

Table 1. Receiver Characteristics Over Common Mode Voltage

INPUT		MEASURED	OUTPUT	
$V_{CANH}$	$V_{CANL}$	$ V_{ID} $	R	
12 V	11.1 V	900 mV	L	$V_{OL}$
-6.1 V	-7 V	900 mV	L	
-1 V	-7 V	6 V	L	
12 V	6 V	6 V	L	
-6.5 V	-7 V	500 mV	H	$V_{OH}$
12 V	11.5 V	500 mV	H	
-7 V	-1 V	6 V	H	
6 V	12 V	6 V	H	
open	open	X	H	

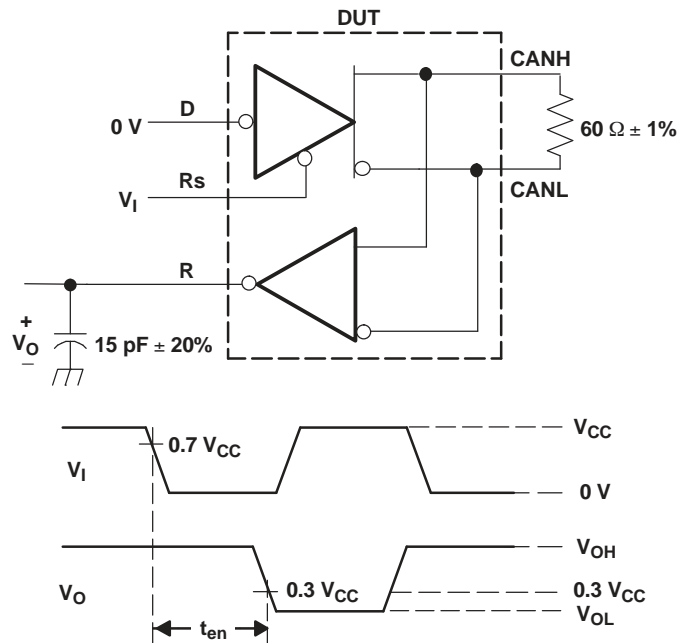
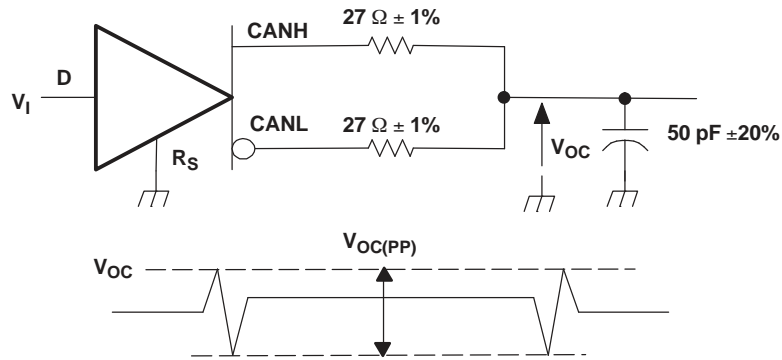

Figure 8.  $t_{en}$  Test Circuit and Voltage Waveforms



- A. The input pulse is supplied by a generator having the following characteristics: PRR  $\leq$  125 kHz, 50% duty cycle,  $t_r \leq$  6 ns,  $t_f \leq$  6 ns,  $Z_O = 50 \Omega$ .

Figure 9. Peak-to-Peak Common Mode Output Voltage

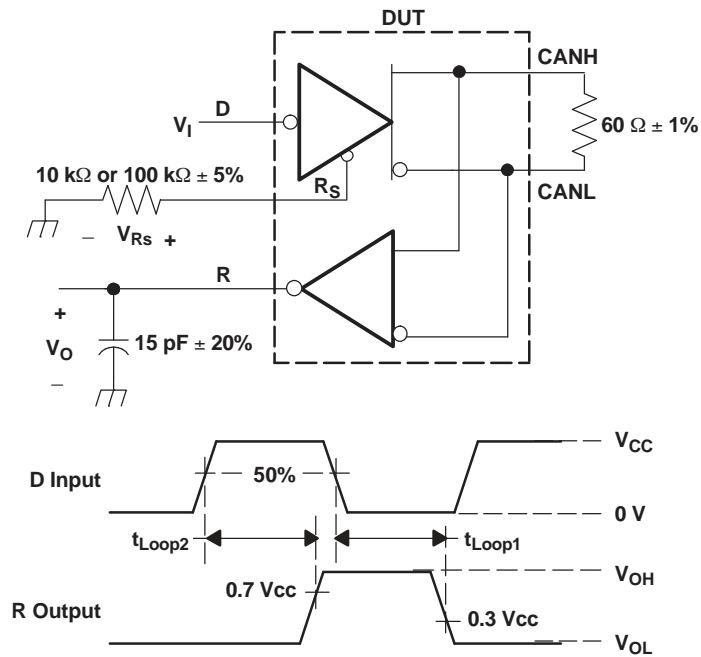

Figure 10.  $t_{LOOP}$  Test Circuit and Voltage Waveforms

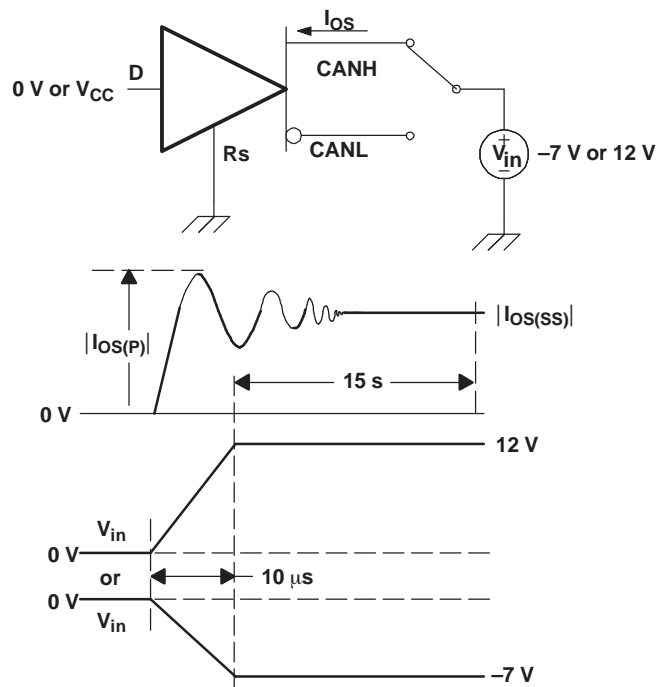
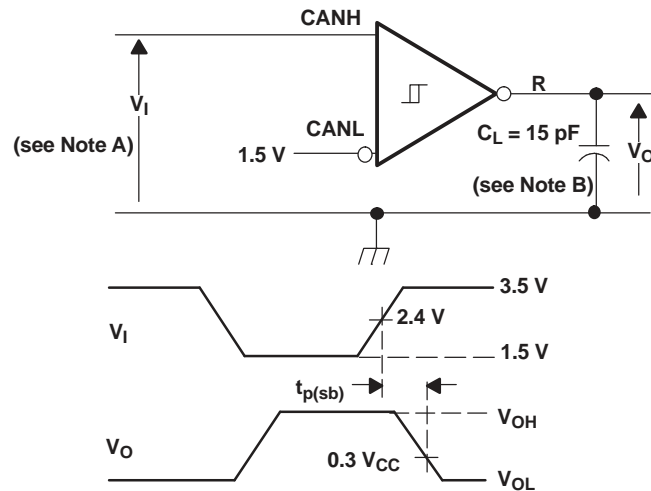

Figure 11. Driver Short-Circuit Test



- A. The input pulse is supplied by a generator having the following characteristics: PRR  $\leq$  125 kHz, 50% duty cycle,  $t_r \leq 6$  ns,  $t_f \leq 6$  ns,  $Z_O = 50 \Omega$ .
- B.  $C_L$  includes instrumentation and fixture capacitance within  $\pm 20\%$ .

Figure 12. Receiver Propagation Delay in Standby Test Circuit and Waveforms

DEVICE INFORMATION

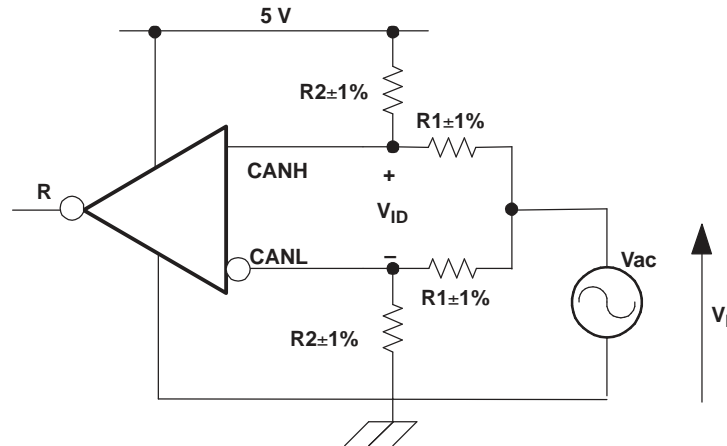

$V_{ID}$	R1	R2
500 mV	50 $\Omega$	450 $\Omega$
900 mV	50 $\Omega$	227 $\Omega$



A. All input pulses are supplied by a generator having the following characteristics:  $f < 1.5$  MHz,  $T_A = 25^\circ\text{C}$ ,  $V_{CC} = 5$  V.

Figure 13. Common-Mode Input Voltage Rejection Test

FUNCTION TABLES

Table 2. DRIVER

INPUTS D	Voltage at $R_s$ , $V_{Rs}$	OUTPUTS		BUS STATE
		CANH	CANL	
L	$V_{Rs} < 1.2$ V	H	L	Dominant
H	$V_{Rs} < 1.2$ V	Z	Z	Recessive
Open	X	Z	Z	Recessive
X	$V_{Rs} > 0.75 V_{CC}$	Z	Z	Recessive

Table 3. RECEIVER

DIFFERENTIAL INPUTS [ $V_{ID} = V(\text{CANH}) - V(\text{CANL})$ ]	OUTPUT R <sup>(1)</sup>
$V_{ID} \geq 0.9$ V	L
$0.5\text{V} < V_{ID} < 0.9$ V	?
$V_{ID} \leq 0.5$ V	H
Open	H

(1) H = high level; L = low level; X = irrelevant; ? = indeterminate; Z = high impedance

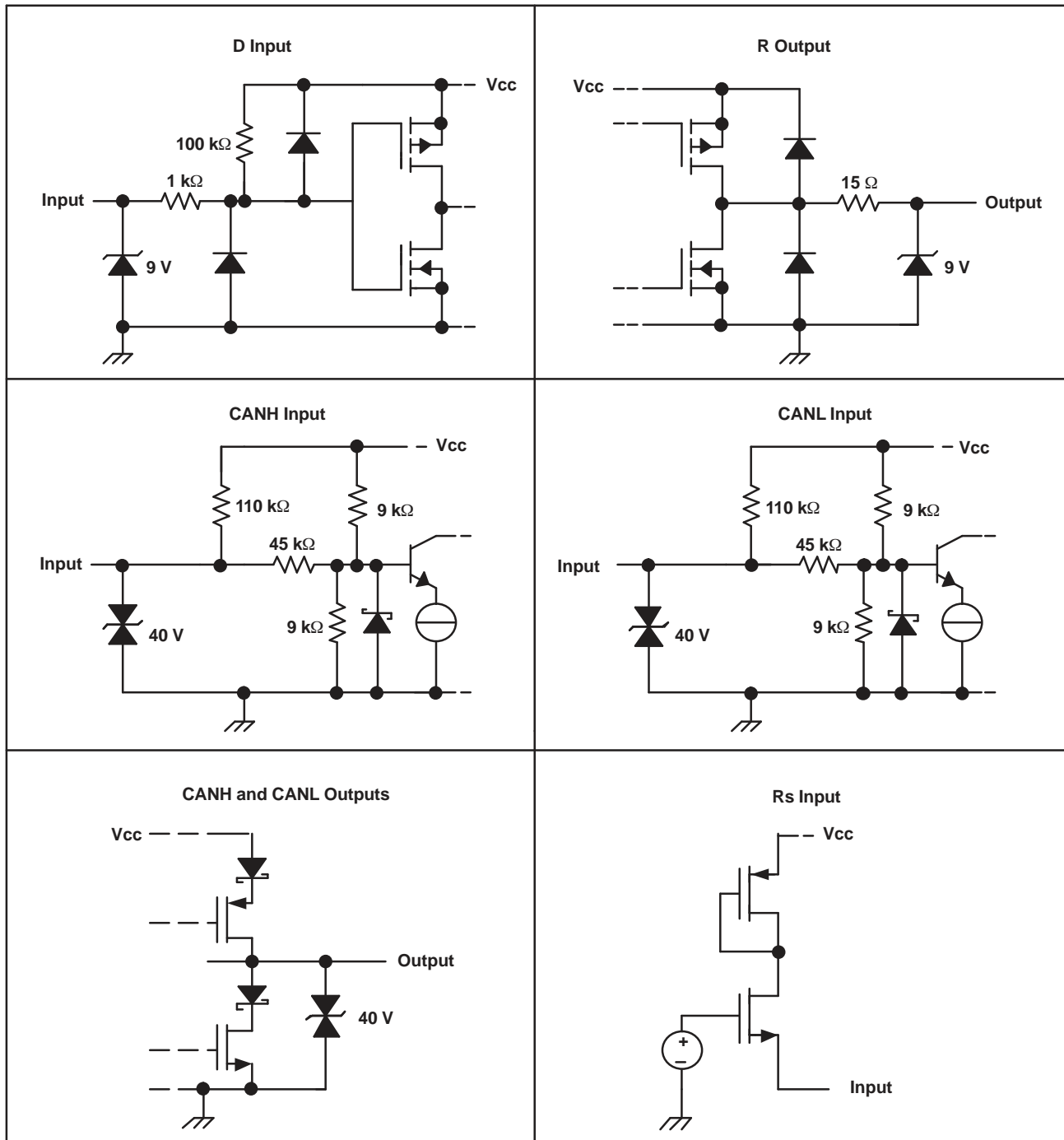

Figure 14. Equivalent Input and Output Schematic Diagrams

TYPICAL CHARACTERISTICS

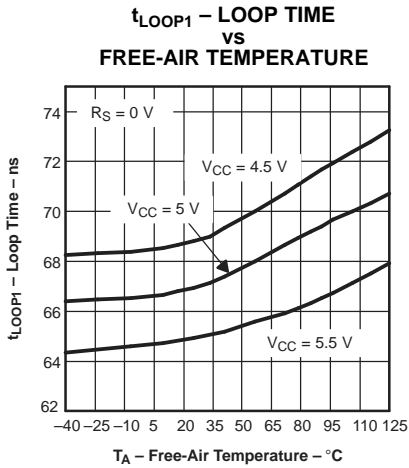

Figure 15.

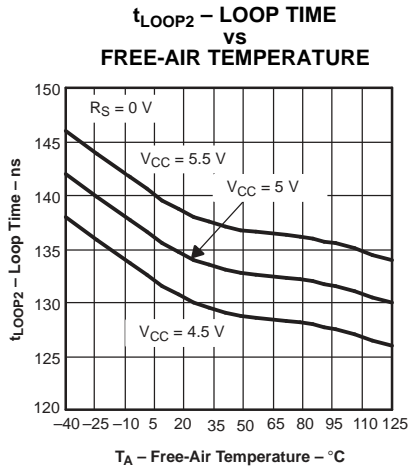

Figure 16.

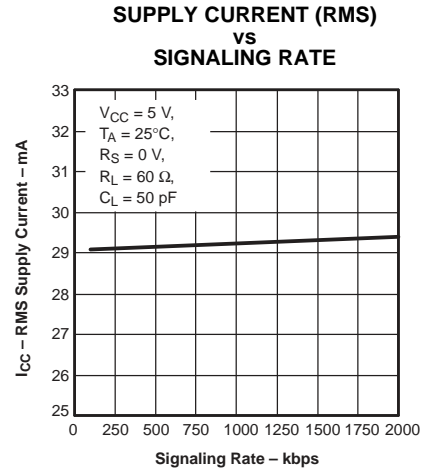

Figure 17.

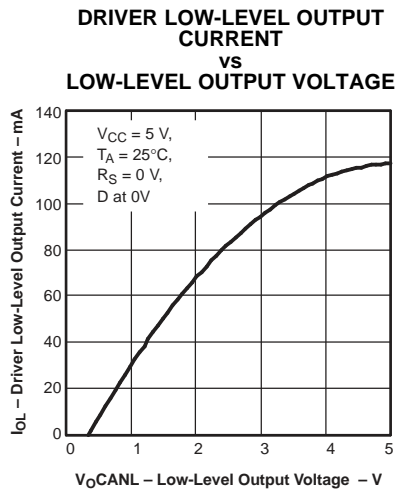

Figure 18.

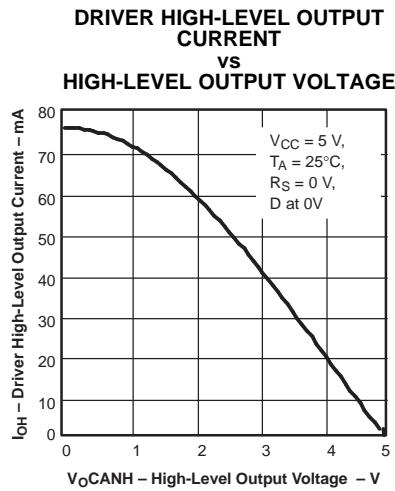

Figure 19.

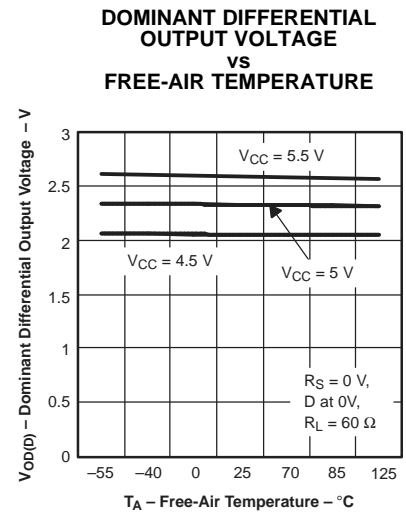

Figure 20.

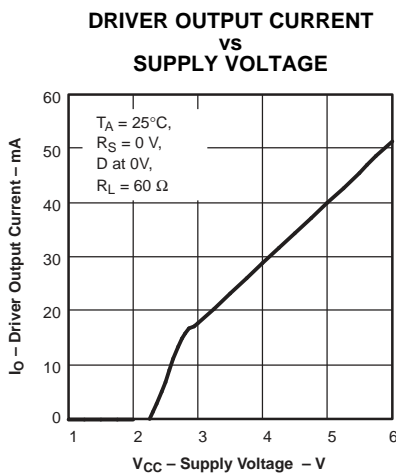

Figure 21.

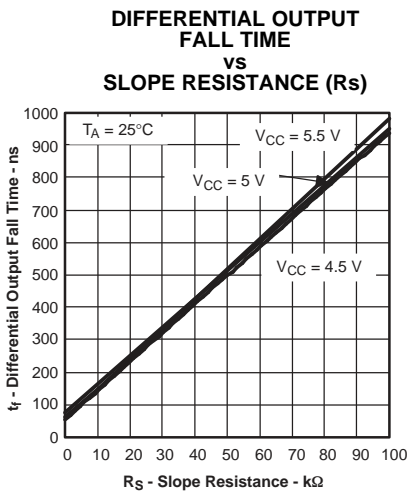

Figure 22.

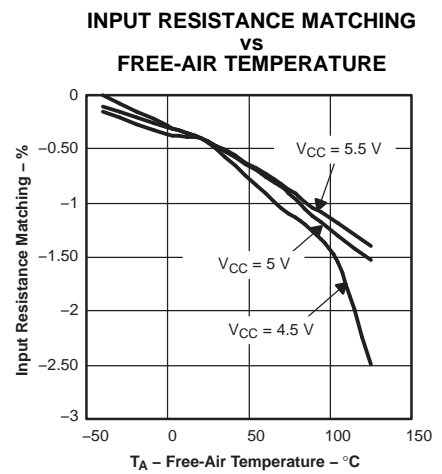

Figure 23.

## APPLICATION INFORMATION

The basics of bus arbitration require that the receiver at the sending node designate the first bit as dominant or recessive after the initial wave of the first bit of a message travels to the most remote node on a network and back again. Typically, this *sample* is made at 75% of the bit width, and within this limitation, the maximum allowable signal distortion in a CAN network is determined by network electrical parameters.

Factors to be considered in network design include the 5 ns/m propagation delay of typical twisted-pair bus cable; signal amplitude loss due to the loss mechanisms of the cable; and the number, length, and spacing of drop-lines (stubs) on a network. Under strict analysis, variations among the different

oscillators in a system must also be accounted for with adjustments in signaling rate and stub and bus length. Table 4 lists the maximum signaling rates achieved with the SN65HVD251 in high-speed mode with several bus lengths of category 5, shielded twisted-pair (CAT 5 STP) cable.

**Table 4. Maximum Signaling Rates for Various Cable Lengths**

BUS LENGTH (m)	SIGNALING RATE (kbps)
30	1000
100	500
250	250
500	125
1000	62.5

The ISO 11898 standard specifies a maximum bus length of 40 m and maximum stub length of 0.3 m with a maximum of 30 nodes. However, with careful design, users can have longer cables, longer stub lengths, and many more nodes on a bus. (Note: Non-standard application may come with a trade-off in signaling rate.) A bus with a large number of nodes requires a transceiver with high input impedance such as the HVD251.

The Standard specifies the interconnect to be a single twisted-pair cable (shielded or unshielded) with 120-Ω characteristic impedance ( $Z_0$ ). Resistors equal to the characteristic impedance of the line terminate both ends of the cable to prevent signal reflections. Unterminated drop-lines connect nodes to the bus and should be kept as short as possible to minimize signal reflections.

Connectors, while not specified by the ISO 11898 standard, should have as little effect as possible on standard operating parameters such as capacitive loading. Although unshielded cable is used in many applications, data transmission circuits employing CAN transceivers are usually used in applications requiring a rugged interconnection with a wide common-mode voltage range. Therefore, shielded cable is recommended in these electronically harsh environments, and when coupled with the -2-V to 7-V common-mode range of tolerable ground noise specified in the standard, helps to ensure data integrity. The HVD251 extends data integrity beyond that of the standard with an extended -7-V to 12-V range of common-mode operation.

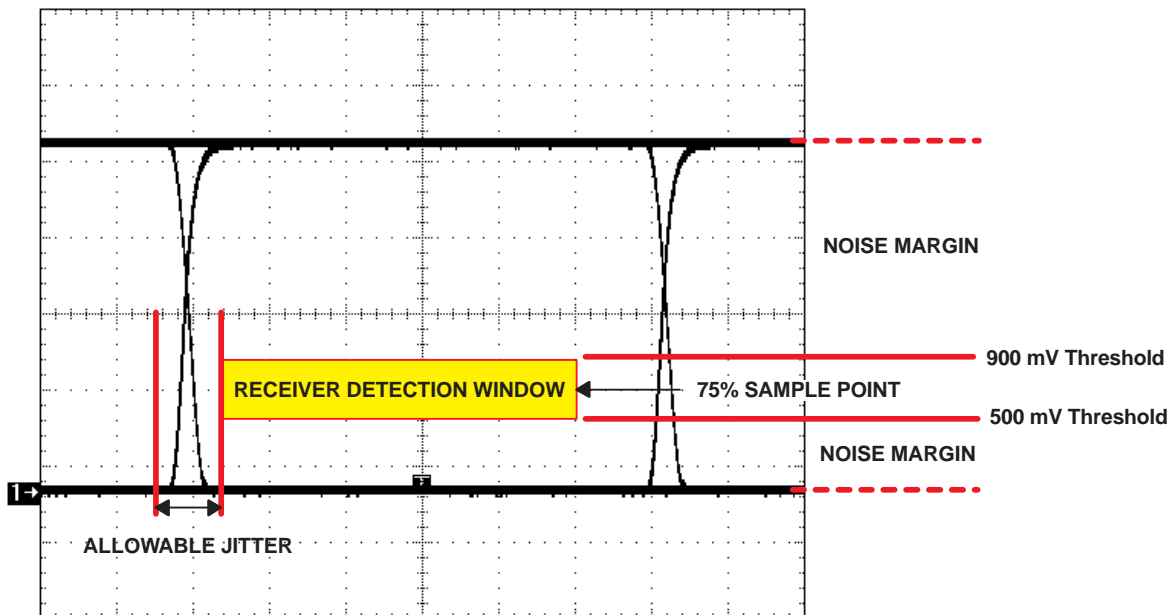

**Figure 24. Typical CAN Differential Signal Eye Pattern**

An eye pattern is a useful tool for measuring overall signal quality. As displayed in [Figure 24](#), the differential signal changes logic states in two places on the display, producing an eye. Instead of viewing only one logic crossing on the scope, an entire *bit* of data is brought into view. The resulting eye pattern includes all effects of systemic and random distortion, and displays the time during which a signal may be considered valid.

The height of the eye above or below the receiver threshold voltage level at the sampling point is the noise margin of the system. Jitter is typically measured at the differential voltage zero-crossing during the logic state transition of a signal. Note that jitter present at the receiver threshold voltage level is considered by some to be a more effective representation of the jitter at the input of a receiver.

As the sum of skew and noise increases, the eye closes and data is corrupted. Closing the width decreases the time available for accurate sampling, and lowering the height enters the 900 mV or 500 mV threshold of a receiver.

Different sources induce noise onto a signal. The more obvious noise sources are the components of a transmission circuit themselves; the signal transmitter, traces and cables, connectors, and the receiver. Beyond that, there is a termination dependency, cross-talk from clock traces and other proximity effects,  $V_{CC}$  and ground bounce, and electromagnetic interference from nearby electrical equipment.

The balanced receiver inputs of the HVD251 mitigate most sources of signal corruption, and when used with a quality shielded twisted-pair cable, help ensure data integrity.

**Typical Application**

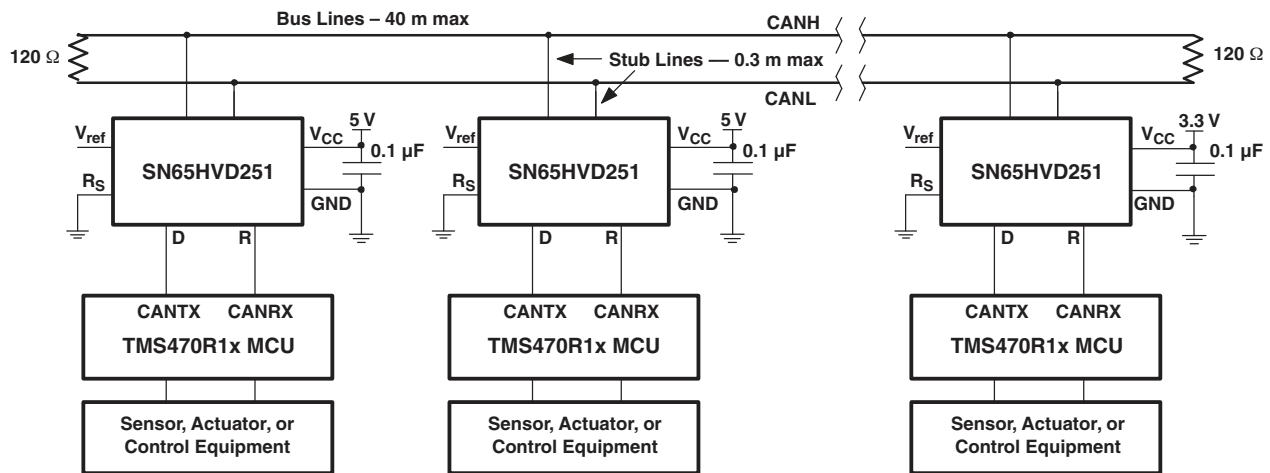

**Figure 25. Typical HVD251 Application**



**PACKAGING INFORMATION**

Orderable Device	Status (1)	Package Type	Package Drawing	Pins	Package Qty	Eco Plan (2)	Lead finish/ Ball material (6)	MSL Peak Temp (3)	Op Temp (°C)	Device Marking (4/5)	Samples
SN65HVD251QDRQ1	ACTIVE	SOIC	D	8	2500	RoHS & Green	NIPDAU	Level-1-260C-UNLIM	-40 to 125	251Q1	Samples

(1) The marketing status values are defined as follows:

**ACTIVE:** Product device recommended for new designs.

**LIFEBUY:** TI has announced that the device will be discontinued, and a lifetime-buy period is in effect.

**NRND:** Not recommended for new designs. Device is in production to support existing customers, but TI does not recommend using this part in a new design.

**PREVIEW:** Device has been announced but is not in production. Samples may or may not be available.

**OBSOLETE:** TI has discontinued the production of the device.

(2) **RoHS:** TI defines "RoHS" to mean semiconductor products that are compliant with the current EU RoHS requirements for all 10 RoHS substances, including the requirement that RoHS substance do not exceed 0.1% by weight in homogeneous materials. Where designed to be soldered at high temperatures, "RoHS" products are suitable for use in specified lead-free processes. TI may reference these types of products as "Pb-Free".

**RoHS Exempt:** TI defines "RoHS Exempt" to mean products that contain lead but are compliant with EU RoHS pursuant to a specific EU RoHS exemption.

**Green:** TI defines "Green" to mean the content of Chlorine (Cl) and Bromine (Br) based flame retardants meet JS709B low halogen requirements of <=1000ppm threshold. Antimony trioxide based flame retardants must also meet the <=1000ppm threshold requirement.

(3) MSL, Peak Temp. - The Moisture Sensitivity Level rating according to the JEDEC industry standard classifications, and peak solder temperature.

(4) There may be additional marking, which relates to the logo, the lot trace code information, or the environmental category on the device.

(5) Multiple Device Markings will be inside parentheses. Only one Device Marking contained in parentheses and separated by a "-" will appear on a device. If a line is indented then it is a continuation of the previous line and the two combined represent the entire Device Marking for that device.

(6) Lead finish/Ball material - Orderable Devices may have multiple material finish options. Finish options are separated by a vertical ruled line. Lead finish/Ball material values may wrap to two lines if the finish value exceeds the maximum column width.

**Important Information and Disclaimer:**The information provided on this page represents TI's knowledge and belief as of the date that it is provided. TI bases its knowledge and belief on information provided by third parties, and makes no representation or warranty as to the accuracy of such information. Efforts are underway to better integrate information from third parties. TI has taken and continues to take reasonable steps to provide representative and accurate information but may not have conducted destructive testing or chemical analysis on incoming materials and chemicals. TI and TI suppliers consider certain information to be proprietary, and thus CAS numbers and other limited information may not be available for release.

In no event shall TI's liability arising out of such information exceed the total purchase price of the TI part(s) at issue in this document sold by TI to Customer on an annual basis.

**OTHER QUALIFIED VERSIONS OF SN65HVD251-Q1 :**

- Catalog: [SN65HVD251](#)

NOTE: Qualified Version Definitions:

- Catalog - TI's standard catalog product

# D0008A

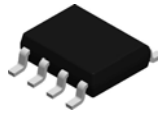

## PACKAGE OUTLINE

SOIC - 1.75 mm max height

SMALL OUTLINE INTEGRATED CIRCUIT

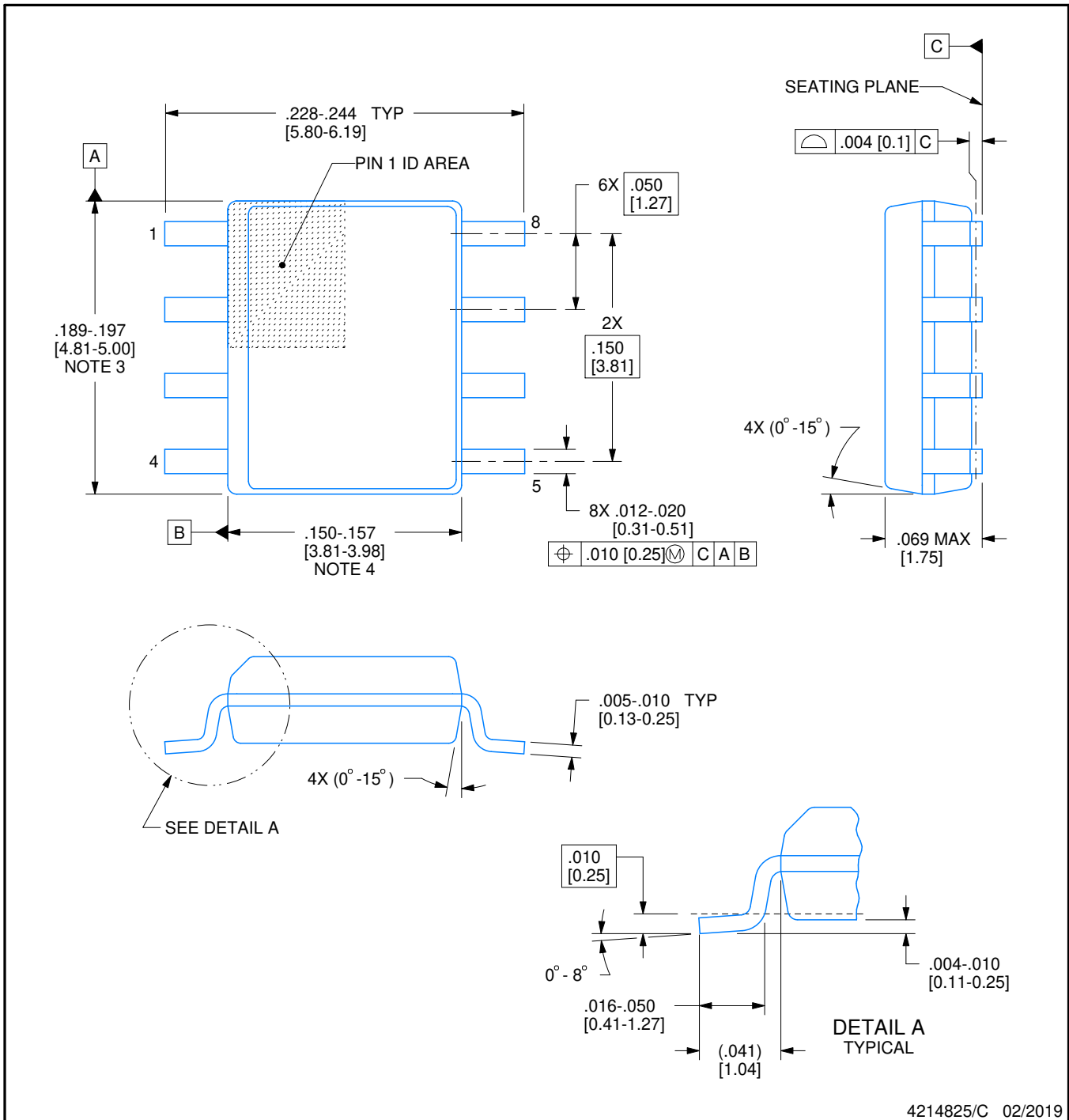

4214825/C 02/2019

### NOTES:

1. Linear dimensions are in inches [millimeters]. Dimensions in parenthesis are for reference only. Controlling dimensions are in inches. Dimensioning and tolerancing per ASME Y14.5M.
2. This drawing is subject to change without notice.
3. This dimension does not include mold flash, protrusions, or gate burrs. Mold flash, protrusions, or gate burrs shall not exceed .006 [0.15] per side.
4. This dimension does not include interlead flash.
5. Reference JEDEC registration MS-012, variation AA.

# EXAMPLE BOARD LAYOUT

D0008A

SOIC - 1.75 mm max height

SMALL OUTLINE INTEGRATED CIRCUIT



LAND PATTERN EXAMPLE  
EXPOSED METAL SHOWN  
SCALE:8X



SOLDER MASK DETAILS

4214825/C 02/2019

NOTES: (continued)

- 6. Publication IPC-7351 may have alternate designs.
- 7. Solder mask tolerances between and around signal pads can vary based on board fabrication site.

# EXAMPLE STENCIL DESIGN

D0008A

SOIC - 1.75 mm max height

SMALL OUTLINE INTEGRATED CIRCUIT



SOLDER PASTE EXAMPLE  
BASED ON .005 INCH [0.125 MM] THICK STENCIL  
SCALE:8X

4214825/C 02/2019

NOTES: (continued)

8. Laser cutting apertures with trapezoidal walls and rounded corners may offer better paste release. IPC-7525 may have alternate design recommendations.
9. Board assembly site may have different recommendations for stencil design.

## IMPORTANT NOTICE AND DISCLAIMER

TI PROVIDES TECHNICAL AND RELIABILITY DATA (INCLUDING DATASHEETS), DESIGN RESOURCES (INCLUDING REFERENCE DESIGNS), APPLICATION OR OTHER DESIGN ADVICE, WEB TOOLS, SAFETY INFORMATION, AND OTHER RESOURCES "AS IS" AND WITH ALL FAULTS, AND DISCLAIMS ALL WARRANTIES, EXPRESS AND IMPLIED, INCLUDING WITHOUT LIMITATION ANY IMPLIED WARRANTIES OF MERCHANTABILITY, FITNESS FOR A PARTICULAR PURPOSE OR NON-INFRINGEMENT OF THIRD PARTY INTELLECTUAL PROPERTY RIGHTS.

These resources are intended for skilled developers designing with TI products. You are solely responsible for (1) selecting the appropriate TI products for your application, (2) designing, validating and testing your application, and (3) ensuring your application meets applicable standards, and any other safety, security, or other requirements. These resources are subject to change without notice. TI grants you permission to use these resources only for development of an application that uses the TI products described in the resource. Other reproduction and display of these resources is prohibited. No license is granted to any other TI intellectual property right or to any third party intellectual property right. TI disclaims responsibility for, and you will fully indemnify TI and its representatives against, any claims, damages, costs, losses, and liabilities arising out of your use of these resources.

TI's products are provided subject to TI's Terms of Sale ([www.ti.com/legal/termsofsale.html](http://www.ti.com/legal/termsofsale.html)) or other applicable terms available either on [ti.com](http://ti.com) or provided in conjunction with such TI products. TI's provision of these resources does not expand or otherwise alter TI's applicable warranties or warranty disclaimers for TI products.

Mailing Address: Texas Instruments, Post Office Box 655303, Dallas, Texas 75265  
Copyright © 2020, Texas Instruments Incorporated