

MC33HB2001

10 A H-bridge, SPI programmable brushed DC motor driver

Rev. 10.0 — 28 October 2020

Product data sheet

1 General description

The MC33HB2001 is a SMARTMOS monolithic H-Bridge Power IC, enhanced with SPI configurability and diagnostic capabilities. It is designed primarily for DC motor or servo motor control applications within the specified current and voltage limits.

The MC33HB2001 is able to control inductive loads with peak currents greater than 10 A. The nominal continuous average load current is 3.0 A. A current mirror output provides an analog feedback signal proportional to the load current.

This part is designed to specifically address the ISO 26262 safety requirements. It meets the stringent requirements of automotive applications and is fully AEC-Q100 grade 1 qualified.

2 Simplified application diagram

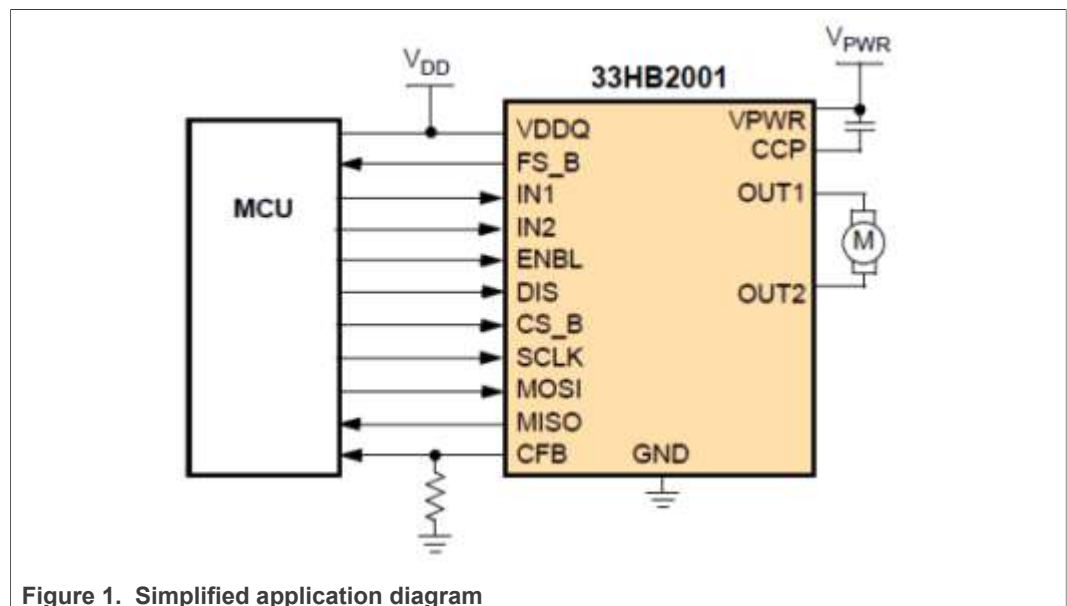

Figure 1. Simplified application diagram

3 Features and benefits

- Advanced diagnostic reporting via a serial peripheral interface (SPI): charge pump undervoltage, overvoltage, and undervoltage on VPWR, short to ground and short to VPWR for each output, open load, temperature warning and overtemperature shutdown
- Thermal management: Excellent thermal resistance of <1.0 °C/W between junction and case (exposed pad)



- Eight selectable slew rates via the SPI: 0.25 V/ μ s to more than 16 V/ μ s for EMI and thermal performance optimization
- Four selectable current limits via the SPI: 5.4/7.0/8.8/10.7 A covering a wide range of applications
- Can be operated without SPI with default slew rate of 2.0 V/ μ s and a 7.0 A current limit threshold
- Highly accurate real-time current feedback through a current mirror output signal with less than 5.0 % error
- Drives inductive loads in a full H-bridge or Half-bridge configuration
- Overvoltage protection places the load in high-side recirculation (braking) mode with notification in H-bridge mode
- Wide operating range: 5.0 V to 28 V operation
- Low $R_{DS(on)}$ integrated MOSFETs: Maximum of 125 m Ω ($T_J = 150\text{ }^\circ\text{C}$) for each MOSFET
- Internal protection for overtemperature, undervoltage, and short-circuit by signaling the error condition and disabling the outputs
- I/O pins can withstand up to 36 V
- AEC-Q100 grade 1 qualified

4 Applications

- Electronic throttle control
- Exhaust gas recirculation control (EGR)
- Turbo, swirl and whirl and waste flap control
- Electric pumps, motor control and auxiliaries

5 Ordering information

Table 1. Orderable parts

Part number ^[1]	Operating temperature	Package
MC33HB2001EK	$T_A = -40\text{ }^\circ\text{C}$ to $125\text{ }^\circ\text{C}$	32-pin SOICW exposed pad
MC33HB2001FK	$T_J = -40\text{ }^\circ\text{C}$ to $150\text{ }^\circ\text{C}$	32-pin PQFN exposed pad

[1] To order parts in tape and reel, add the R2 suffix to the part number.

Valid orderable part numbers are provided on the web. To determine the orderable part numbers for this device, go to <http://www.nxp.com> and perform a part number search.

6 Internal block diagram

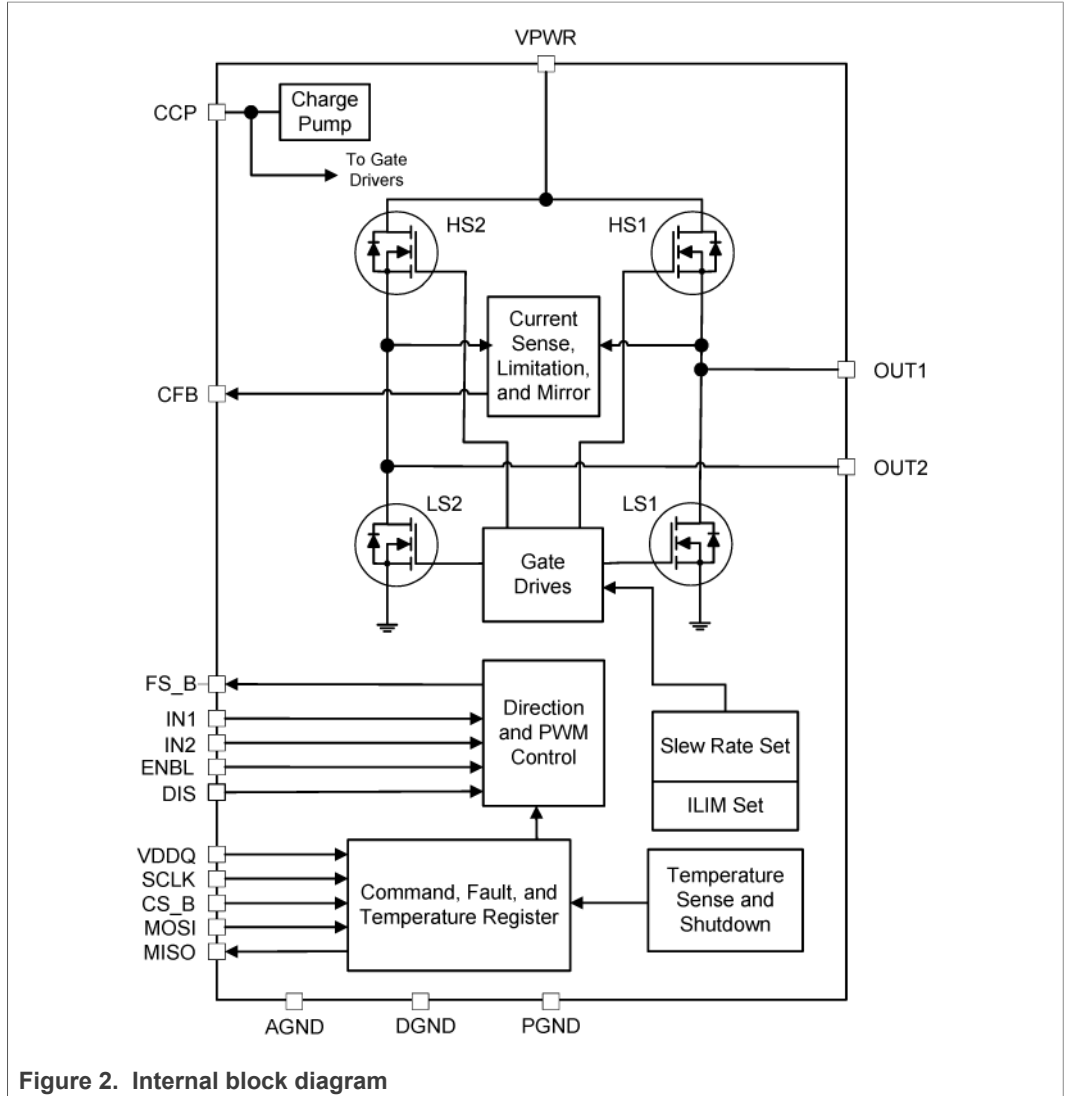

Figure 2. Internal block diagram

7 Pinning information

7.1 Pinning

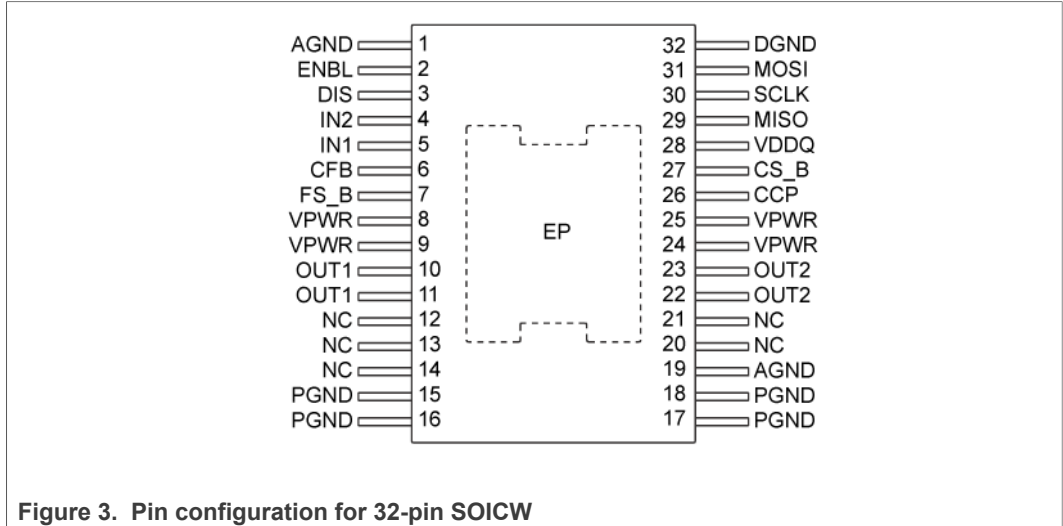

Figure 3. Pin configuration for 32-pin SOICW

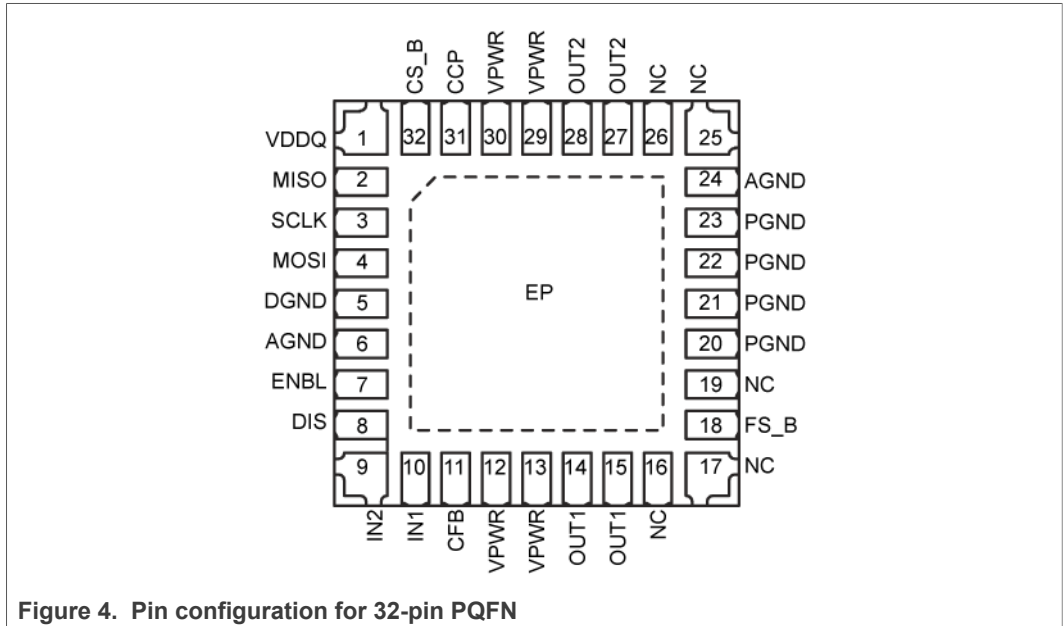

Figure 4. Pin configuration for 32-pin PQFN

7.2 Pin description

For functional description of each pin see [Section 7.3 "Functional pin description"](#).

Table 2. Pin description

Symbol	32-pin SOICW	32-pin PQFN	Pin function	Definition
AGND	1, 19	6, 24	GND	Ground for analog ^[1]

Table 2. Pin description...continued

Symbol	32-pin SOICW	32-pin PQFN	Pin function	Definition
ENBL	2	7	D_In	When ENBL is logic HIGH, the H-Bridge is operational. When ENBL is logic LOW, the H-Bridge outputs are tri-stated and placed in Sleep mode.
DIS	3	8	D_In	When DIS is logic HIGH, both OUT1 and OUT2 are tri-stated
IN2	4	9	D_In	Logic input control of OUT2
IN1	5	10	D_In	Logic input control of OUT1
CFB	6	11	A_Out	The load current feedback output provides ground referenced 0.25 % of the high-side output current.
FS_B	7	18	D_Out	Open drain active LOW status flag output
VPWR	8, 9, 24, 25	12, 13, 29, 30	Supply	These pins must be connected together physically as close as possible and directly soldered down to a wide, thick, low resistance supply plane on the PCB.
OUT1	10, 11	14, 15	A_Out	Source of HS1 and drain of LS1
—	12, 13, 14, 20, 21	16, 17, 19, 25, 26	NC	No connection to die or substrate
PGND	15, 16, 17, 18	20, 21, 22, 23	GND	Power ground for OUT1 and OUT2 ^[1]
OUT2	22, 23	27, 28	A_Out	Source of HS2 and drain of LS2
CCP	26	31	A_Out	External reservoir capacitor connection for the internal charge pump; connected to VPWR
CS_B	27	32	D_In	SPI control chip select bar input pin
VDDQ	28	1	Supply	Logic level bias
MISO	29	2	D_Out	Provides digital data from HB2001 to the MCU
SCLK	30	3	D_In	SPI control clock input pin
MOSI	31	4	D_In	SPI control data input pin from MCU
DGND	32	5	GND	Ground for logic ^[1]
EP	EP	EP	GND	Thermal exposed pad – connected to substrate ^[1]

[1] All PGND, AGND, DGND and EP pins must be connected together with very low-impedance on the PCB.

7.3 Functional pin description

7.3.1 Logic bias input (VDDQ)

VDDQ supplies a level shifted bias voltage for the logic level outputs designed to be read by the microprocessor/microcontroller. This pin applies the logic supply voltage to MISO making the output logic levels compliant to logic systems from 3.3 V to 5.0 V. See [Section 10.3 "VDDQ digital output supply voltage"](#) for more details.

7.3.2 Supply voltage (VPWR)

VPWR is the power supply input for the H-bridge. The input voltage range with full performance is from 8.0 V to 28 V. In either case, the maximum allowable transient

voltage during the event such as load dump is 40 V. Exceeding this limit could result in an avalanche breakdown, as discussed in [Section 11.3 "Output avalanche protection"](#). A Zener clamp and/or an appropriately valued capacitor are common methods of limiting the transient. This pin must be externally protected against application of a reverse voltage through an external inverted N-channel MOSFET, diode or switched relay.

7.3.3 Outputs (OUT1 and OUT2)

The OUT1 and OUT2 outputs drive the bi-directional DC motor. Each output has two internal N-channel MOSFETs connected in a Half-bridge configuration between VPWR and ground. Only one internal MOSFET is ON at one time for each output. The turn ON/OFF slew times are determined by the selected SPI slew time register contents.

7.3.4 Inputs (IN1 and IN2)

The IN1 and IN2 inputs determine the direction of current flow in the H-Bridge by directing the PWM input to one of the low-side MOSFETs (see [Table 21](#)). When a change in the current direction is commanded via the microprocessor/microcontroller, the PWM switches from one low-side MOSFET to the other without shoot-through current in the H-Bridge. Both MOSFETs cannot be turned ON simultaneously in the same Half-bridge.

7.3.5 Enable inputs (ENBL)

The ENBL pin at logic [0] disables all four of the output drivers (outputs tri-stated) and the part goes into Sleep mode. The ENBL pin at logic [1] enables the part functionality.

7.3.6 Disable inputs (DIS)

The DIS pin at logic [1] disables all four of the output drivers (outputs tri-stated) and the part goes into Standby mode. However, it does not put the part in Sleep mode. The DIS pin is at logic [0] does not inhibit the output.

7.3.7 Current recopy (CFB)

High-side FETs have a current recopy feature through an internal current-mirror which supplies 1/400th of the load current. The current recopy has better than 5.0 % accuracy for load currents between 2.0 A and 10 A. An external resistor may be connected to the CFB pin (R_{CFB}), which sets current to voltage gain. The circuit operates properly in the presence of high-frequency noise. An external capacitor is used to provide filtering. Tie to GND through a resistor if not used.

$$V_{CFB} = \frac{I_{OUT}}{400} \times R_{CFB}$$

7.3.8 Charge pump capacitor (CCP)

This pin is the charge pump output pin for connecting the external charge pump reservoir capacitor. A typical value is 100 nF. The capacitor must be connected from the CCP pin to the VPWR pin. The part does not operate properly without the external reservoir capacitor.

7.3.9 Serial peripheral interface (SPI)

The MC33HB2001 has a serial peripheral interface consisting of Chip Select (CS_B), Serial Clock (SCLK), Master IN Slave Out (MISO), and Master Out Slave In (MOSI). This device is configured as a SPI slave and is daisy-chainable (single CS_B for multiple SPI slaves). See [Section 9.6 "16-bit SPI interface"](#) for detailed information on the SPI.

7.3.9.1 Serial clock (SCLK)

The SCLK input is the clock signal input for synchronization of serial data transfer. This pin has TTL/CMOS level compatible input voltages, which allows proper operation with microprocessors using a 3.3 V to 5.0 V supply. When CS_B is asserted low, the MOSI data reads on the SCLK falling edge and the MISO data is updated on the SCLK rising edge.

7.3.9.2 Serial data output (MISO)

The MISO is the SPI data out pin. When CS_B is asserted (low), the MSB is the first bit of the word transmitted on MISO and the LSB is the last bit of the word transmitted on MISO. After all 16 bits of the fault register are transmitted, the MISO output sequentially transmits the digital data received on the MOSI pin. This allows the microprocessor to distinguish a shorted MOSI pin condition. The MISO output continues to transmit the input data from the MOSI input until CS_B eventually transitions from a logic [0] to a logic [1]. The MISO output pin is in a high-impedance condition unless CS_B is low. When active, the output is "rail to rail", depending on the voltage at the VDDQ pin.

7.3.9.3 Serial data input (MOSI)

The MOSI input takes data from the microprocessor while CS_B is asserted (low). The MSB is the first bit of each word received on MOSI and the LSB is the last bit of each word received on MOSI. The MC33HB2001 serially wraps around the MOSI input bits to the MISO output after the MISO output transmits its fault flag bits. This pin has TTL/CMOS level compatible input voltages, allowing proper operation with microprocessors using a 3.3 V to 5.0 V supply.

7.3.9.4 Chip select (CS_B)

The CS_B input selects this device for serial transfers. The SPI applies the contents of the I/O register when CS_B rises. When CS_B falls, the I/O register is loaded with the contents of the previously addressed register. This pin has TTL/CMOS level compatible input voltages, which allows proper operation with microprocessors using a 3.3 V to 5.0 V supply.

7.3.10 Status fault (FS_B)

This pin is the device fault status output which signals the MCU of any fault. The fault status pin goes low to report system status according to the bits selected in the Fault Status Mask register as explained in [Table 15](#). This output is active LOW open drain structure, which requires a pull-up resistor to VDD. For more details on this pin, see [Table 21](#).

8 General product characteristics

8.1 Maximum ratings

Table 3. Maximum ratings

All voltages are with respect to ground, unless otherwise noted. Exceeding these ratings may cause a malfunction or permanent damage to the device.

Symbol	Description (Rating)	Min.	Max.	Unit
SUPPLY				
V _{PWR}	Supply voltage (VPWR)	-0.3	40	V
V _{DDQ}	Logic bias input (VDDQ)	-0.3	36	V
V _{AGND}	Analog ground (AGND)	-0.3	0.3	V
V _{DGND}	Digital ground (DGND)	-0.3	0.3	V
V _{PGND}	Power ground (PGND)	-0.3	0.3	V
CHARGE PUMP				
V _{CCP}	Charge pump (CCP) voltage	-0.3	V _{PWR} + 12	V
DIGITAL I/O				
V _{IN1}	Input 1 (IN1) voltage	-0.3	36	V
V _{IN2}	Input 2 (IN2) voltage	-0.3	36	V
V _{DIS}	Disable (DIS) voltage	-0.3	36	V
V _{ENBL}	Enable (ENBL) voltage	-0.3	36	V
V _{FS_B}	Status flag (FS_B) voltage	-0.3	36	V
SPI				
V _{MISO}	Serial data output (MISO) voltage	-0.3	V _{DDQ} + 0.3	V
V _{MOSI}	Serial data input (MOSI) voltage	-0.3	36	V
V _{CSB}	Chip select (CS_B) voltage	-0.3	36	V
V _{SCLK}	Serial clock (SCLK)	-0.3	36	V
OUTPUTS				
V _{OUTX}	OUT1 and OUT2 voltage	-0.3	V _{PWR} + 2.0	V
V _{CFB}	Current recopy (CFB)	-0.3	30	V
CURRENTS				
I _{POUTX}	OUTx peak current Transient current (< 5.0 ms) T _J ≤ 150 °C	—	16	A
I _{CLAMP}	Digital pin current in clamping mode ENBL, DIS, MOSI, CS_B, SCLK, IN1, IN2	-3.0	3.0	mA
ESD PROTECTION				

Table 3. Maximum ratings...continued

All voltages are with respect to ground, unless otherwise noted. Exceeding these ratings may cause a malfunction or permanent damage to the device.

Symbol	Description (Rating)	Min.	Max.	Unit
	ESD Voltage ^{[1] [2]}			
	Human Body Model (HBM)			
V _{ESD_A1}	Local pins, all pins except VPWR, OUT1, OUT2	—	±2000	V
V _{ESD_G1}	Global pins: VPWR, OUT1, OUT2	—	±4000	
	Charge Device Model (CDM)			
V _{ESD_A2}	All pins	—	±500	
V _{ESD_C2}	Corners pins	—	±750	
V _{ESD_C2}	Machine Model			
	All pins	—	±200	

[1] Human body model: AEC-Q100

[2] Charged Device model and Machine model: AEC-Q100 Rev H

8.2 Thermal characteristics

Table 4. Thermal ratings

Symbol	Description (Rating)	Min.	Max.	Unit
THERMAL RATINGS				
T _J	Operational junction temperature			
	Continuous	−40	150	°C
	Transient	−40	195	
T _A	Operational ambient temperature ^[1]	−40	125	°C
T _{STG}	Storage temperature	−65	150	°C
T _{PPRT}	Peak package reflow temperature during reflow ^{[2] [3]}	—	—	°C
MC33HB2001EK THERMAL RESISTANCE AND PACKAGE DISSIPATION RATINGS				
R _{ΘJA}	Junction to ambient natural convection – single layer board (1s) ^{[4] [5]}	—	75.7	°C/W
R _{ΘJA}	Junction to ambient natural convection – four layer board (2s2p) ^{[4] [5]}	—	23.9	°C/W
R _{ΘJB}	Junction to board ^[6]	—	7.1	°C/W
R _{ΘJCBOTTOM}	Junction to case (bottom) ^[7]	—	0.66	°C/W
Ψ _{JT}	Junction to package top – natural convection ^[8]	—	2.97	°C/W
MC33HB2001FK THERMAL RESISTANCE AND PACKAGE DISSIPATION RATINGS				
R _{ΘJA}	Junction to ambient natural convection – single layer board (1s) ^{[4] [5]}	—	63.4	°C/W
R _{ΘJA}	Junction to ambient natural convection – four layer board (2s2p) ^{[4] [5]}	—	21.55	°C/W
R _{ΘJB}	Junction to board ^[6]	—	6.41	°C/W
R _{ΘJCBOTTOM}	Junction to case (bottom) ^[7]	—	0.61	°C/W
Ψ _{JT}	Junction to package top – natural convection ^[8]	—	2.6	°C/W

[1] The circuit specification describes IC operation within the parametric operating range defined in the electrical characteristic table.

[2] Pin soldering temperature limit is for 10 seconds maximum duration. Not designed for immersion soldering. Exceeding these limits may cause malfunction or permanent damage to the device.

[3] NXP's Package Reflow capability meets Pb-free requirements for JEDEC standard J-STD-020C. For Peak Package Reflow Temperature and Moisture Sensitivity Levels (MSL), go to nxp.com, search by part number. Remove prefixes/suffixes and enter the core ID to view all orderable parts (for MC33xxxD enter 33xxx), and review parametrics.

[4] Junction temperature is a function of die size, on-chip power dissipation, package thermal resistance, mounting site (board) temperature, ambient temperature, air flow, power dissipation of other components on the board, and board thermal resistance.

[5] Per JEDEC JESD51-2 with natural convection for horizontally oriented board. Board meets JESD51-9 specification for 1s or 2s2p board, respectively.

- [6] Thermal resistance between the die and the printed circuit board per JEDEC JESD51-8. Board temperature is measured on the top surface of the board near the package.
- [7] Thermal resistance between the die and the solder pad on the bottom of the package. Interface resistance is ignored.
- [8] Thermal characterization parameter indicating the temperature difference between package top and the junction temperature per JEDEC JESD51-2. When Greek letters (Ψ) are not available, the thermal characterization parameter is written as Psi-JT.

8.3 Operating conditions

This section describes the operating conditions of the device. Conditions apply to the following data, unless otherwise noted.

Table 5. Nominal operation

Within the range of functionality, all functionalities have to be guaranteed. All voltages refer to GND. Currents are positive into and negative out of the specified pin. $T_J = -40\text{ }^\circ\text{C}$ to $150\text{ }^\circ\text{C}$, unless otherwise specified.

Symbol	Description (Rating)	Min.	Max.	Unit
SUPPLY VOLTAGE				
V_{PWR}	Functional operating supply voltage range— V_{PWR}	5.0	28	V
SPI				
f_{SPI}	SPI frequency range	0.5	10	MHz

Table 6. Supply current consumption

$V_{PWR} = 5.0\text{ V}$ to 28 V , $T_J = -40\text{ }^\circ\text{C}$ to $150\text{ }^\circ\text{C}$, unless otherwise specified.

Symbol	Description (Rating)	Min.	Max.	Unit
VPWR SUPPLY CURRENT CONSUMPTIONS				
I_{VPWR}	Operating mode— V_{PWR}	[1] —	20	mA
$I_{VPWR(SLEEP)}$	Sleep mode, measured at $V_{PWR} = 12\text{ V}$	[2] —	50	μA
LEAKAGE CURRENTS FOR THE FUNCTIONS CONNECTED TO VPWR				
$I_{OUTLEAK}$	Output leakage current, outputs off, $V_{PWR} = 28\text{ V}$ $V_{OUTx} = VPWR$ $V_{OUTx} = GND$	— -60	100 —	μA

[1] ENBL = Logic [1], $I_{OUT} = 0\text{ A}$

[2] ENBL = Logic[0], DIS = Logic[1] and $I_{OUT} = 0\text{ A}$

8.3.1 Reverse battery

To protect against a reverse battery condition, a dedicated device to block reverse current must be populated in the application, as shown in [Figure 21](#) (with a diode).

Some applications require operation at very low battery voltages (start-stop applications), and many systems have multiple H-bridges in parallel, which require high current reverse battery protection with very low voltage drops during the operation. In such applications, an external, reverse-polarity, FET may be used instead of the reverse protection diode, to lower the voltage drop from battery to V_{PWR} pins. The CCP pin can be used to bias the gate of an N-channel FET, provided the bias current requirement is less than $20\text{ }\mu\text{A}$. In [Figure 22](#), the NPN transistor is used for fast response of the N-Channel FET during turn-off.

8.3.2 Digital I/Os characteristics

Table 7. Digital I/Os characteristics

$V_{PWR} = 5.0\text{ V to }28\text{ V}$, $T_J = -40\text{ }^\circ\text{C to }150\text{ }^\circ\text{C}$, unless otherwise specified.

Symbol	Parameter	Min.	Max.	Unit
DIGITAL INPUTS				
V_{IH_X}	Input high-voltage	2.0	—	V
V_{IL_X}	Input low-voltage	—	0.8	V
V_{HYS_X}	Input voltage threshold hysteresis	100	—	mV
R_{PD_X}	Input pull-down resistance—MOSI, SCLK, ENBL, IN1, IN2	40	175	k Ω
R_{PU_X}	DIS, CS_B Input pull-up resistance to 5.0 V	40	175	k Ω
C_{IN}	Input capacitance	—	12	pF
DIGITAL OUTPUTS				
V_{OH_X}	MISO output high-voltage, with -1.0 mA	$0.8 \times V_{DDQ}$	—	V
V_{OL_X}	MISO output low-voltage, with 1.0 mA	—	0.4	V
I_{MISO_LK}	MISO tri-state leakage current	-10	10	μA
$V_{OL_FS_B}$	FS_B low-voltage, with 1.0 mA	—	0.4	V
$R_{PU_FS_B}$	FS_B output pull-up resistance to 5.0 V	100	500	k Ω

9 General IC functional description and application information

9.1 Introduction

The MC33HB2001 is a programmable H-bridge, power integrated circuit (IC) designed to drive DC motors or bi-directional solenoid controlled actuators, such as throttle control or exhaust gas recirculation actuators. It is particularly well suited for the harsh environment found in automotive power train systems. The MC33HB2001 is designed to specifically address the ISO 26262 safety standard requirements. The key characteristic of this versatile driver is configurability. The selectable slew rate permits the customer to choose the slew rate needed for performance and noise suppression. The Serial Peripheral Interface (SPI) allows the system microprocessor to clear the fault register, select a programmable current limit, and select the slew rate.

The MC33HB2001 is designed to drive a bi-directional DC motor using pulse-width modulation (PWM) for speed and torque control. A current mirror output provides an analog feedback signal proportional to the load current. SPI diagnostic reporting includes, open load, short-to-battery, short-to-ground, die temperature range, overvoltage, and undervoltage.

9.2 Features

- Advanced diagnostic reporting via the serial peripheral interface (SPI)
 - Charge pump undervoltage
 - Overvoltage and undervoltage on VPWR
 - Short to ground as well as short to VPWR for each output
 - Open load
 - Temperature warning
 - Overtemperature shutdown
- Excellent thermal resistance of $<1.0\text{ }^\circ\text{C/W}$ between junction and case (exposed pad)

- Eight selectable slew rates via the SPI from 0.25 V/μs to more than 16 V/μs, giving the user flexibility to perform trade-offs between low EMI and better thermal performance
- Active current limiting with four selectable current limits via the SPI: 5.4/7.0/8.8/10.7 A covering a wide range of applications
- Can be operated without SPI with default slew rate of 2.0 V/μs and a 7.0 A current limit threshold. See [Figure 21](#) for operation without SPI.
- Efficient thermal management scheme by reducing the switching losses to ensure continuous operation and availability of the part under harsh operating conditions
- Accurate real-time current feedback through a current mirror output signal with less than 5.0 % error
- Configurable for full H-bridge or Half-bridge operation through the SPI
- Overvoltage protection places the load in high-side recirculation (braking) mode and signal the error condition in H-bridge mode
- Wide operating range: 5.0 V to 28 V operation
- Low R_{DS(on)} integrated MOSFETs: Maximum 125 mΩ (T_J = 150 °C) for each MOSFET
- Internal protection for short-circuit, overtemperature, and undervoltage by signaling the error condition and disabling the outputs
- I/O pins can withstand up to 36 V

9.3 Functional block diagram

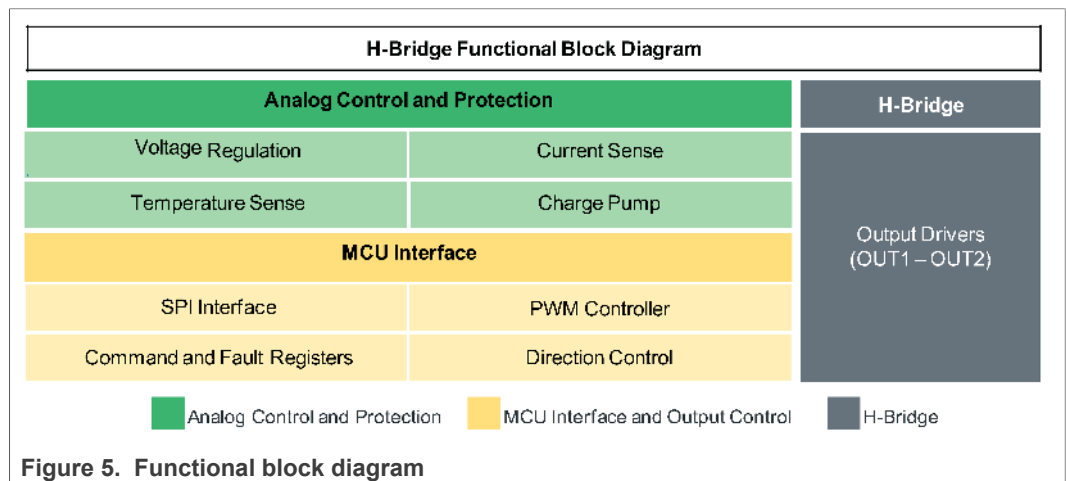

Figure 5. Functional block diagram

9.4 Functional description

9.4.1 H-bridge output drivers (OUT1 and OUT2)

The MC33HB2001 power IC provides the means to efficiently drive a DC motor in both forward and reverse shaft rotation via a monolithic H-bridge comprising low R_{DS(on)} N-channel MOSFETs and integrated control circuitry. The switching action of the H-bridge can be pulse-width modulated to obtain both torque and speed control, with slew rates selectable from 0.25 V/μs to 16 V/μs in eight steps, giving the user flexibility to perform trade offs between meeting the EMI requirements and minimize switching losses. The outputs comprise four power MOSFETs configured as a standard H-bridge, controlled by the IN1 and IN2 inputs.

9.4.2 Analog control, protection, and diagnostics

The MC33HB2001 has integrated voltage regulators supplying the logic and protection functions internally. This reduces the requirements for external supplies and insures the device is safely controlled at all times when battery voltage is applied. An integrated charge pump provides the required bias levels to insure the output MOSFETs turn fully ON when commanded. Each MOSFET provides feedback to the protection circuitry by way of a current sensor. Each sense signal is compared with programmable overcurrent levels and produces an immediate shutdown in case of a high current short-circuit. The high-side current sense is also used for producing a current limiting PWM to reduce overload conditions as determined by the programmable limits. The high-side current sense is available to the MCU as an analog current proportional to the load current.

Each MOSFET has overtemperature protection circuitry disabling the device. A thermal warning sets a flag in the SPI register when the device is approaching a protection limit. A thermal management scheme decreases the current limiting PWM frequency, while keeping the average current at the selected limit.

The MC33HB2001 consists of advanced diagnostics and protection features such as open load detection, overvoltage sense and protection, undervoltage protection, or charge pump undervoltage detection.

9.4.3 MCU interface and output control

The SPI and control logic signals are compatible with both 5.0 V and 3.3 V logic systems. The SPI provides an easy to configure interface for the MCU through programmable control of output slew rates, current limits, enabling/disabling of outputs, SPI equivalent of inputs (VIN1 and VIN2), and mode of operation (H-bridge/half-bridge). The status register makes detailed diagnostics available for protective and warning functions. The output drivers are controlled by the input signals ENBL, DIS, IN1, and IN2 using the parallel inputs and VIN1, VIN2, as well as EN using the SPI control.

9.5 Modes of operation

9.5.1 Description

The operating modes are:

- **Sleep mode**
All MC33HB2001 functions are disabled. The current consumption does not exceed the sleep-state current specification.
- **Standby mode**
All MC33HB2001 logic are fully operational with the outputs in a high-impedance state.
- **Normal mode**
All MC33HB2001 functions are fully operational. Any detected faults transition the device to Fault mode.
- **Fault mode**
Certain of functions are forced off and FS_B signal is latched to logic [0] indicating a fault.

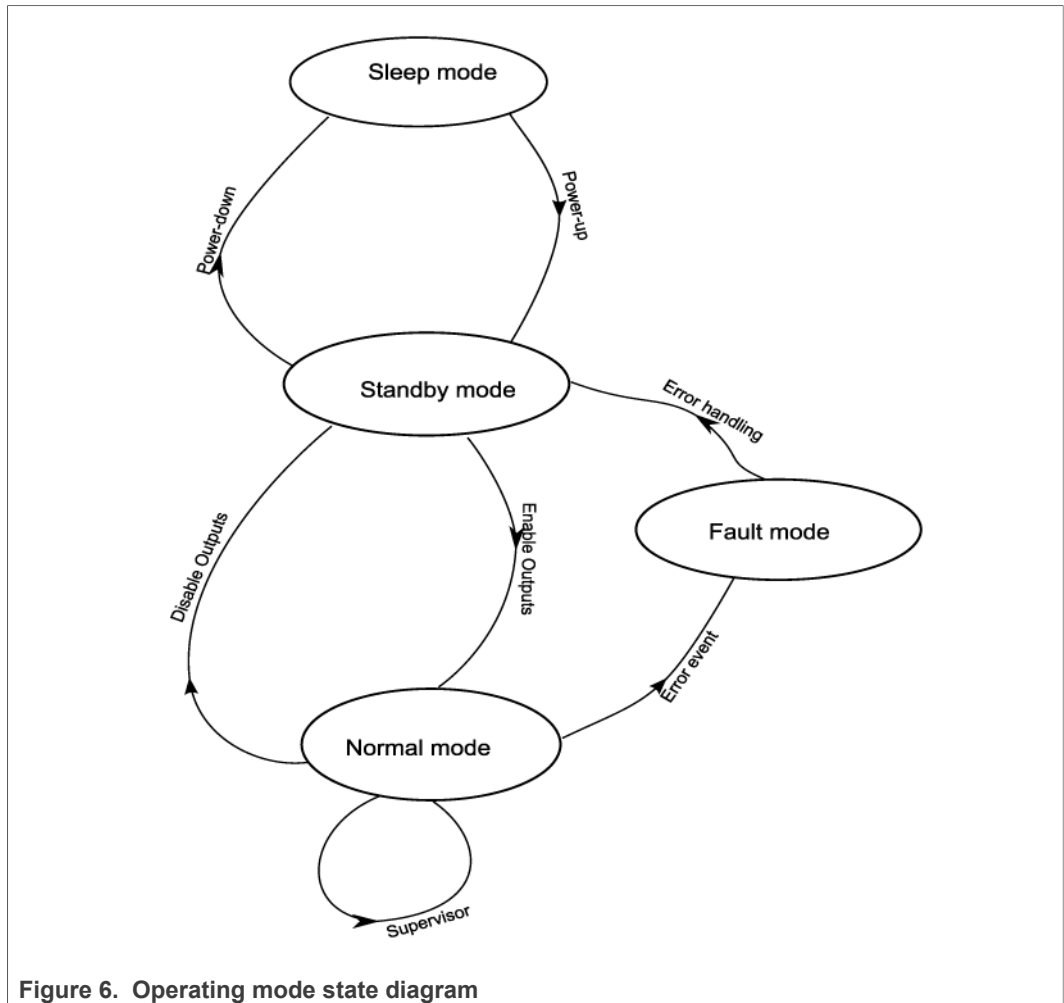

Figure 6. Operating mode state diagram

The MC33HB2001 wakes up by EN going to a logic high state. If a valid wake-up event occurs while the V_{PWR} voltage level is above the specified threshold, the regulators power-up sequence is initiated as illustrated in [Figure 7](#).

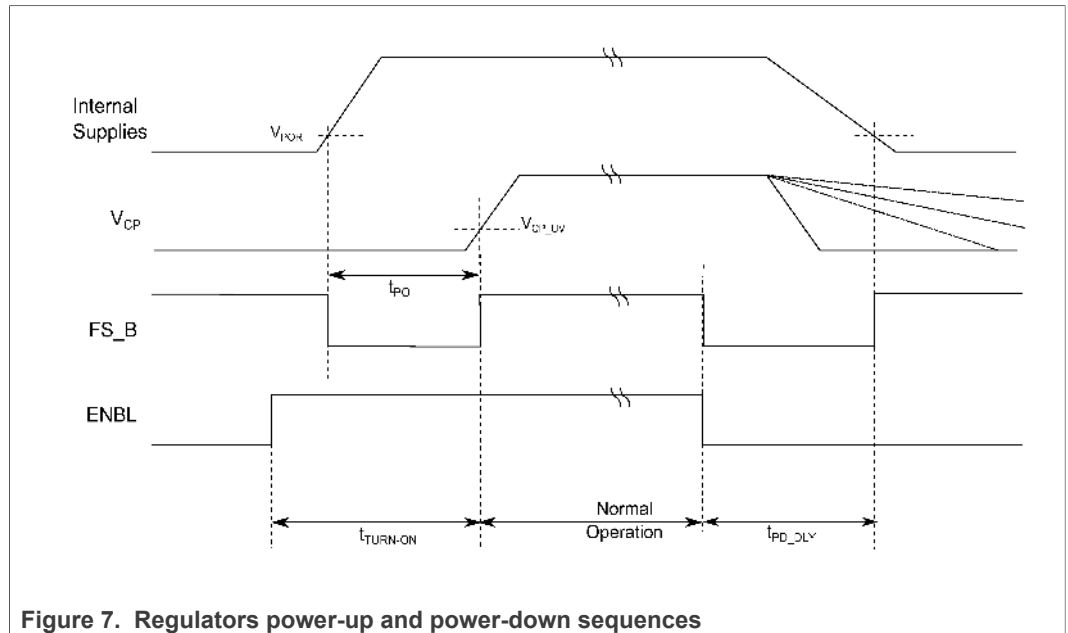

Figure 7. Regulators power-up and power-down sequences
 On Power-up, Fault Status (FS_B) activates after the internal supplies reach their operating threshold. All regulators acquire their steady-state by the turn-on delay time ($t_{TURN-ON}$). On power-up, FS_B is active for at least t_{PO} , and then deactivates after V_{CP} is greater than the undervoltage threshold (V_{CP_UV}) and all faults are clear. When ENBL transitions to logic LOW, the outputs turn off (high-impedance state) and FS_B goes low. Power-down starts t_{PD_DLY} after ENBL goes low. DIS must also be low for FS_B to deactivate. On Power-down, FS_B is activated until the internal supplies are disabled.

9.5.2 Electrical characteristics

Table 8. Electrical characteristics
 $V_{PWR} = 5.0\text{ V to }28\text{ V}$, $T_J = -40\text{ }^\circ\text{C to }150\text{ }^\circ\text{C}$, unless otherwise specified.

Symbol	Characteristic	Min.	Typ.	Max.	Unit
Wake-up					
$t_{TURN-ON}$	Turn-on delay time. Time from ENBL going high to FS_B returning high ^[1]	—	—	1.0	ms
t_{PO}	Turn-on Status time. Minimum pulse width on FS_B during power up	1.0	—	2.0	μs
t_{PD_DLY}	Turn-off delay time. ENBL going low until FS_B is allowed to go high	8.0	—	11	μs

[1] ENBL is a digital input and has the characteristics defined in [Table 7](#).

9.6 16-bit SPI interface

9.6.1 Description

The Serial Peripheral Interface (SPI) has the following features:

- Full duplex, 4-wire synchronous communication
- Slave mode operation only
- Fixed SCLK polarity and phase requirements
- Fixed 16-bit command word
- SCLK operation up to 10 MHz

The SPI communication works as follows:

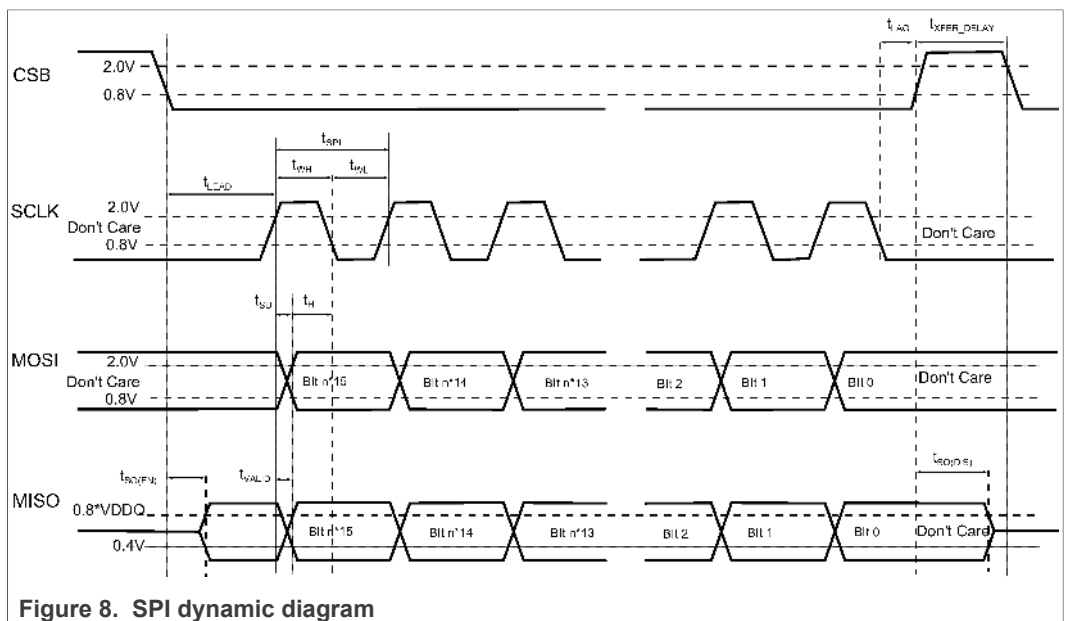

Figure 8. SPI dynamic diagram

SPI communication is “MSB first” and is composed of 16 SCLK cycles. The MOSI data is read on SCLK falling edge and the MISO data is updated on SCLK rising edge. The daisy-chain feature passes data in excess of 16 bits to the next device in line. If the number of clock pulses within CS_B low is not more than 0 and an integer multiple of 16, the current SPI communication is ignored and a framing error is recorded in the status register. Both the serial input and the serial output data are valid on the SCLK falling edge, and transitions on the rising edge of SCLK.

The content reported by the MC33HB2001 is the previous selected register address at the time CS_B goes low. On the first SPI communication after enable goes high, the first register sent on the MISO line is the status register. When addressing a READ register, the content bits are ignored. See [Table 9](#) for detail on timing parameters.

Note:

It is recommended to use good programming practices incorporating writes to SPI registers, immediately verified by reads to the registers. This ensures a reliable communication between MCU and the device. MCU is responsible for detecting any malfunction in the communication that may come up due to hardware or software failure.

9.6.2 Electrical characteristics

Table 9. Electrical characteristics

$V_{DDQ} = 3.13\text{ V to }5.25\text{ V}$, $T_J = -40\text{ }^\circ\text{C to }150\text{ }^\circ\text{C}$, unless otherwise specified.

Symbol	Characteristic	Min.	Typ.	Max.	Unit
SPI INTERFACE TIMING					
f_{SPI}	Recommended frequency of SPI operation, $t_{\text{SPI}} = 1/f_{\text{SPI}}$	0.5	—	10	MHz
t_{LEAD}	Falling edge of CS_B to rising edge of SCLK (required setup time)	30	—	—	ns
t_{LAG}	Falling edge of SCLK to rising edge of CS_B (required setup time)	30	—	—	ns
$t_{\text{XFER_DELAY}}$	No data time between SPI commands	300	—	—	ns
t_{WH}	High time of SCLK	45	$t_{\text{SPI}}/2$	—	ns
t_{WL}	Low time of SCLK	45	$t_{\text{SPI}}/2$	—	ns
t_{SU}	SCLK rising edge to MOSI (required setup time)	15	—	—	ns
$t_{\text{SO(EN)}}$	Time from falling edge of CS_B to MISO low-impedance	—	—	30	ns
$t_{\text{SO(DIS)}}$	Time from rising edge of CS_B to MISO high-impedance	—	—	30	ns
t_{VALID}	Time from falling edge of SCLK to MISO data valid, $V_{DDQ} = 5.0\text{ V}$, $1.0\text{ V} \leq \text{MISO} \leq 4.0\text{ V}$, $CL = 50\text{ pF}$	—	—	30	ns
t_{VALID}	Time from falling edge of SCLK to MISO data valid, $V_{DDQ} = 3.3\text{ V}$, $0.66\text{ V} \leq \text{MISO} \leq 2.64\text{ V}$, $CL = 50\text{ pF}$	—	—	45	ns
t_{H}	Data hold time	30	—	—	ns

9.6.3 SPI fault reporting

The MC33HB2001 has an advanced SPI fault reporting and error detection feature. The fault status register latches a fault at the time a fault is detected.

9.6.3.1 Clearing the fault status

The fault status is cleared when the fault is no longer present and one of three events occurs, this is referred to as "clrflt" throughout this document.

Table 10. Timing parameters for clearing fault status

Symbol	Characteristic	Min.	Typ.	Max.	Unit
$t_{\text{DIS_MIN}}$	The falling edge of a logic signal on DIS clears non-active faults. Minimum pulse width to ensure the faults are cleared.	—	—	1.0	μs
$t_{\text{ENBL_MIN}}$	The rising edge of a logic signal on ENBL clears non-active faults. Minimum pulse width to ensure the faults are cleared.	—	—	1.0	μs
	A write to the status register selectively clears fault status with a '1' in this bit location.				

9.6.3.2 SPI framing error detection

A SPI Framing error is recorded if either of the following two conditions are met:

- The number of clock pulses within CS_B low is not more than 0 and an integer multiple of 16
- Register 00 is addressed for a Write operation

9.6.4 SPI mapping

Bit 15 is 1 for a Write operation and 0 for a Read operation. A write to the status register selectively clears the fault status with a '1' in this bit location, unless the fault is still present.

Table 11. SPI register selection

14	13	Register
0	0	Device Identification (Reserved)
0	1	Status
1	0	Fault Status Mask
1	1	Configuration and Control

Table 12. Device identification (Reserved)

Bit	15	14	13	12	11	10	9	8	7	6	5	4	3	2	1	0
Read	0	0	0	0	0	0	0	0	0	0	0	0	RV3	RV2	RV1	RV0

RV0-RV3 reserved bits. Bit 4 is the device identifier.

Table 13. Status

Bit	15	14	13	12	11	10	9	8	7	6	5	4	3	2	1	0
Name	—	—	—	—	FRM	CP_U	UV	OV	SCP2	SCP1	SCG2	SCG1	OL	OC	TW	OT
Read ^[1]	0	0	1	0	0	0	0	0	0	0	0	0	0	0	0	0
Write	1	0	1	0	X	X	X	X	X	X	X	X	X	X	X	X

[1] The default value for all bits (bit 0 to bit 11) in status register is 0 if no fault is detected in the device.

Table 14. Status bits description

Bit	Bit name	Description
15	—	—
14	—	—
13	—	—
12	—	—
11	FRM	SPI framing error
10	CP_U	Charge pump undervoltage
9	UV	VPWR undervoltage
8	OV	VPWR overvoltage
7	SCP2	Short-circuit to power output 2
6	SCP1	Short-circuit to power output 1
5	SCG2	Short-circuit to ground output 2

Table 14. Status bits description...continued

Bit	Bit name	Description
4	SCG1	Short-circuit to ground output 1
3	OL	Open load
2	OC	Overcurrent - current limit has been activated
1	TW	Thermal warning
0	OT	Overtemperature shutdown

Table 15. Fault status mask

Bit	15	14	13	12	11	10	9	8	7	6	5	4	3	2	1	0
Name	—	—	—	DOV	FRM	CP_U	UV	OV	SCP2	SCP1	SCG2	SCG1	OL	OC	TW	OT
Read ^[1]	0	1	0	0	0	1	1	0	1	1	1	1	0	0	0	1
Write	1	1	0	0	X	X	X	X	X	X	X	X	X	X	X	X

[1] The SPI bits in "Read" section show the default values.

The mask bits are in the same order as the Status bits. A '1' causes the FS_B to become active when this fault is active.

Bit 12 (DOV - Disable overvoltage) configures the response to an overvoltage condition:

- 1 = Disable overvoltage protection (OV bit is warning only)
- 0 = Enable overvoltage protection in Full Bridge mode

Table 16. Configuration and control

Bit	15	14	13	12	11	10	9	8	7	6	5	4	3	2	1	0
Name	—	—	—	CL	TM	AL	ILM1	ILM0	SR2	SR1	SR0	EN	MODE	INPUT	VIN2	VIN1
Read ^[1]	0	1	1	0	1	1	0	1	1	0	0	1	1	0	0	0
Write	1	1	1	X	X	X	X	X	X	X	X	X	X	X	X	X

[1] The SPI bits in "Read" section show the default values.

Table 17. Configuration and control bits description

Bit	Bit name	Description
15	—	—
14	—	—
13	—	—
12	CL	Check for open load (in Full Bridge Standby mode) <ul style="list-style-type: none"> • 1 = Enabled on transition from Standby to Normal mode. Execute test in Standby on transition to 1 • 0 = Disable test
11	TM	Thermal Management mode <ul style="list-style-type: none"> • 1 = Enable change of current limit frequency by control of t_B when OT_W state • 0 = Disable change of current limit frequency by OT_W, t_B shall be set to the slowest setting

Table 17. Configuration and control bits description...continued

Bit	Bit name	Description
10	AL	Active Current Limit mode <ul style="list-style-type: none"> • 1 = Enable active current limit when overcurrent ILIM threshold has been exceeded • 0 = Disable active current limit. Exceeding overcurrent ILIM threshold set OC flag but does not control outputs
9	ILIM1	ILIM Bit 1
8	ILIM0	ILIM Bit 0
7	SR2	Slew Rate Bit 2
6	SR1	Slew Rate Bit 1
5	SR0	Slew Rate Bit 0
4	EN	Disable Outputs <ul style="list-style-type: none"> • 1 = ENABLE output control when ENBL pin is high and DIS pin is low • 0 = DISABLE output control and tri-state outputs
3	MODE	Input Control mode ^[1] <ul style="list-style-type: none"> • 1 = H-bridge control mode • 0 = Half-bridge control mode
2	INPUT	Active INPUT Control mode <ul style="list-style-type: none"> • 1 = SPI control of outputs by way of VIN1 and VIN2, IN1 pin and IN2 pin are disabled • 0 = Parallel control of outputs by way of IN1 pin and IN2 pin, VIN1 and VIN2 are disabled
1	VIN2	Virtual Input 2 (SPI equivalent of IN2) <ul style="list-style-type: none"> • 1 = ON equivalent to IN2 pin at logic high in parallel mode • 0 = OFF equivalent to IN2 pin at logic low in parallel mode
0	VIN1	Virtual Input 1 (SPI equivalent of IN1) <ul style="list-style-type: none"> • 1 = ON equivalent to IN1 pin at logic high in parallel mode • 0 = OFF equivalent to IN1 pin at logic low in parallel mode

[1] When MODE=0 (Half-bridge mode): Active Current Limit mode is disabled, OV is a warning only, SC acts independent on each output, open load is disabled.

9.7 Protection and supervision

The MC33HB2001 includes supervision features which enable advanced diagnostics by monitoring the V_{PWR} undervoltage, V_{PWR} overvoltage and die temperature.

9.7.1 V_{PWR} undervoltage detection

9.7.1.1 Description

When V_{PWR} is less than V_{PWR_FUV} longer than t_{VPWR} all output transistors turn off and remain off until V_{PWR} increases above the V_{PWR_FUV} threshold by V_{PWR_UVHYS} . While ramping up the voltage on V_{PWR} , when V_{PWR} increases to a voltage greater than $V_{PWR_FUV} + V_{PWR_UVHYS}$ for at least t_{VPWR} , the MC33HB2001 starts unrestricted operation.

9.7.1.2 Electrical characteristics

Table 18. V_{PWR_UV} electrical characterization
 $T_J = -40\text{ }^\circ\text{C}$ to $150\text{ }^\circ\text{C}$, unless otherwise specified.

Symbol	Characteristic	Min.	Typ.	Max.	Unit
V_{PWR} UNDERVOLTAGE					
V_{PWR_FUV}	Undervoltage threshold to disable outputs (falling edge)	3.55	—	4.0	V
V_{PWR_UVHYS}	Undervoltage hysteresis	250	—	450	mV
t_{VPWR}	Undervoltage detection filter time	—	—	10	μs
V_{PWR_POR}	Power On Reset with VPWR falling	2.3	—	3.1	V

9.7.2 V_{PWR} overvoltage detection

If VPWR voltage is higher than OV_{HSD} threshold longer than t_{OV_HSD} , the OV status bit is set and the device is in an overvoltage condition. When the device is in an overvoltage condition and is also in H-bridge mode (MODE bit =1), both OUT1 and OUT2 low-side switches controlling the load is turned off and both OUT1 and OUT2 high-side switches are turned on to drain the energy in the load.

When VPWR voltage drops by more than OV_{HYS} below the OV_{HSD} threshold, the outputs are restored to operation without an overvoltage condition. The OV status bit is not reset until clr_flt conditions are satisfied.

9.7.2.1 Electrical characteristics

Table 19. V_{PWR_OV} electrical characterization
 $T_J = -40\text{ }^\circ\text{C}$ to $150\text{ }^\circ\text{C}$, unless otherwise specified.

Symbol	Characteristic	Min.	Typ.	Max.	Unit
OVERVOLTAGE DETECTION					
$V_{PWR_OV_HSD}$	Overvoltage detection threshold	33	35	37	V
$V_{PWR_OV_HYS}$	Overvoltage detection hysteresis	2.3	2.45	2.5	V
t_{OV_HSD}	Overvoltage detection filter time	[1] —	—	3.0	μs

[1] Measured in H-bridge mode, 1.0 A resistive load, SR = 000, measured from FS_B low to both $V_{OUT} \geq 10\% V_{PWR}$

9.7.3 Die temperature

9.7.3.1 Description

The MC33HB2001 has temperature sensors near the center of each power device.

The threshold of the overtemperature warning (OT_W) is approximately $150\text{ }^\circ\text{C}$ on any power device. Temperature warning condition is defined as exceeding OT_W . When a temperature warning occurs, outputs are not shutdown. However, the SPI status bit shows the actual status at accessing time. This is a non-latching condition and the status clears when the temperature falls below the hysteresis threshold. Further action is taken on temperature warning as described in [Section 9.6.4 "SPI mapping"](#) and [Section 10.4.1.4 "Active current limit regulation"](#).

When the temperature is above the overtemperature threshold (OT) for the defined filter time (t_{OT}), the driver latches off, the SPI OT fault bit is set. This is a latching fault and

requires performing `clr_flt`, as described in [Section 9.6.3.1 "Clearing the fault status"](#), after the temperature reduces T_{HYS} below the threshold.

9.7.3.2 Electrical characteristics

Table 20. OT electrical characterization
V_{PWR} = 5.0 V to 28 V, unless otherwise specified.

Symbol	Characteristic	Min.	Typ.	Max.	Unit
OVERTEMPERATURE/TEMPERATURE WARNING					
OT _W	Overtemperature warning detection threshold ^[1]	140	150	165	°C
OT	Overtemperature shutdown threshold ^[1]	165	175	190	°C
T _{HYS}	Overtemperature hysteresis ^[1]	—	12	—	°C
t _{OT}	Temperature warning detection filter time	—	—	11	µs

[1] Guaranteed by characterization.

9.7.4 Truth table

The following truth table summarizes the output response to input states. The tri-state conditions and the status flag are reset using DIS, ENBL, or SPI. The truth table uses the following notations: L = LOW, H = HIGH, X = HIGH or LOW, Xb is inverse of X, and Z = High-impedance.

Table 21. Truth table

Device state	Input conditions				Status FS_B ^[3]	Outputs	
	ENBL	DIS ^[1]	IN1 ^[2]	IN2 ^[2]		OUT1	OUT2
HALF-BRIDGE CONTROL MODE							
Forward	H	L	H	L	H	H	L
Reverse	H	L	L	H	H	L	H
Freewheeling Low	H	L	L	L	H	L	L
Freewheeling High	H	L	H	H	H	H	H
IN1 Disconnected	H	L	Z	X	H	L	X
IN2 Disconnected	H	L	X	Z	H	X	L
H-BRIDGE CONTROL MODE							
Forward	H	L	H	H	H	H	L
Reverse	H	L	L	H	H	L	H
Freewheel High	H	L	X	L	H	H	H
IN1 Disconnected – Reverse	H	L	Z	X	H	Xb	H
IN2 Disconnected – Freewheel High	H	L	X	Z	H	H	H
PROTECTION							
Disable (DIS)	H	H	X	X	L	Z	Z
DIS Disconnected	H	Z	X	X	L	Z	Z
Undervoltage Lockout ^[4]	H	X	X	X	L	Z	Z
Overtoltage ^[5]	H	X	X	X	L	H	H
Overtemperature ^[6]	H	X	X	X	L	Z	Z
Short-circuit ^[7]	H	X	X	X	L	Z	Z
Sleep mode ENBL	L	X	X	X	H	Z	Z
ENBL Disconnected	Z	X	X	X	H	Z	Z

- [1] SPI bit EN=1 AND DIS=L for table entry DIS=L
- [2] When the SPI bit INPUT = 1, the SPI bit VIN1 behaves the same as IN1 and SPI bit VIN2 behaves the same as IN2.
- [3] Default response for FS_B, SPI programming may change the default behavior.
- [4] In the event of an undervoltage condition, the outputs tri-state and status flag is SET logic LOW. Upon undervoltage recovery the outputs are restored to their original operating condition, FS_B remains low until clr_fit clears the status register.
- [5] In the event of an overvoltage condition, the outputs go to freewheeling high configuration, independent of the input signals, and the status flag is latched to a logic LOW. Upon overvoltage recovery, the outputs are restored to following the input signals but FS_B remains low until clr_fit clears the status register. In Half-bridge mode an overvoltage event does not change the output state.
- [6] When a short-circuit or overtemperature condition is detected, the power outputs are tri-state latched-OFF, independent of the input signals, and the status flag is latched to a logic LOW. To reset from this condition requires the toggling of either DIS, ENBL, or V_PWR or fit_clr from the SPI.
- [7] When in H-bridge control mode, short-circuit controls both OUT1 and OUT2. However, in Half-bridge mode, short-circuit only controls the output which detects the short-circuit.

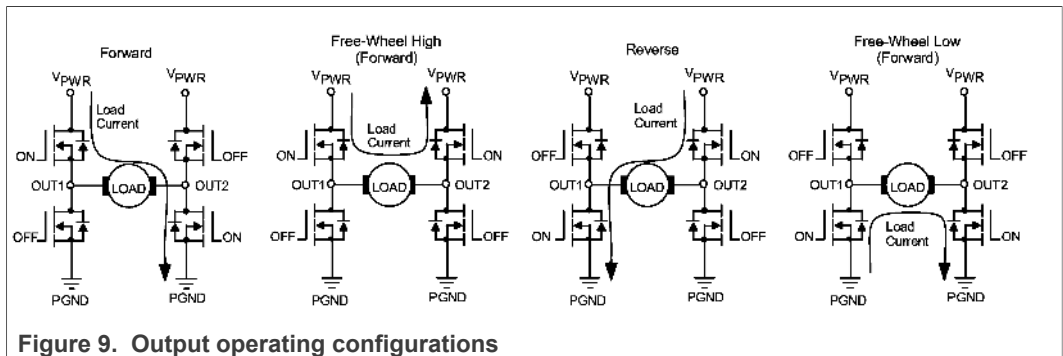

Figure 9. Output operating configurations

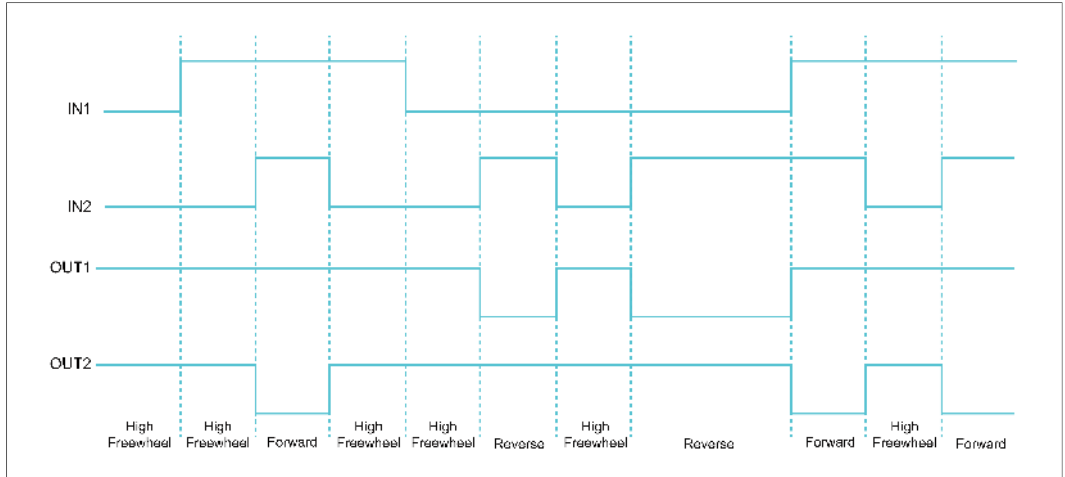

Figure 10. H-bridge operation with ENBL = 1 and DIS = 0

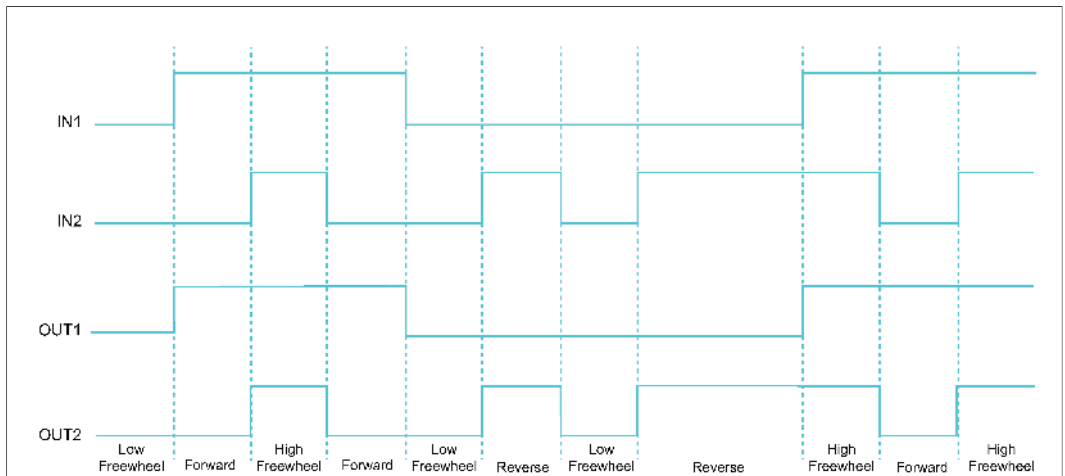

Figure 11. Half-bridge operation with ENBL = 1 and DIS = 0

9.8 Error handling

Table 22. Error handling

Type of error	Detection condition	Action	Clear SPI flag	Restart condition
SUPERVISION				
Overtemperature shutdown	Normal mode	See Table 21	Write Clear Fault SPI bit OT	Latching fault requires clr_ft
Die temperature warning	All except Sleep mode	SPI flag only (TW)	Non-latching auto clears when condition clears	Non-latching fault clears when condition clears
Overcurrent	Normal mode	SPI flag only (OC)	Write Clear Fault SPI bit OC	Latching fault requires clr_ft
Open load	Transition to Normal mode or request from MCU	SPI flag only (OL)	Write Clear Fault SPI bit OL	Information only, no restart required

Table 22. Error handling...continued

Type of error	Detection condition	Action	Clear SPI flag	Restart condition
Short-circuit to Ground Output 1	Normal mode	See Table 21	Write Clear Fault SPI bit SCG1	Latching fault requires clr_ft
Short-circuit to Ground Output 2	Normal mode	See Table 21	Write Clear Fault SPI bit SCG2	Latching fault requires clr_ft
Short-circuit to VPWR Output 1	Normal mode	See Table 21	Write Clear Fault SPI bit SCP1	Latching fault requires clr_ft
Short-circuit to VPWR Output 2	Normal mode	See Table 21	Write Clear Fault SPI bit SCP2	Latching fault requires clr_ft
VPWR Overvoltage	All except Sleep mode	See Table 21	Write Clear Fault SPI bit OV	Non-latching fault clears when condition clears
VPWR Undervoltage	All except Sleep mode	See Table 21	Write Clear Fault SPI bit UV	Non-latching fault clears when condition clears
CP Undervoltage	All except Sleep mode	SPI flag only (CP_UV). No action, except if micro requests a shutdown	Non-latching fault clears when condition clears	Non-latching fault clears when condition clears
SPI failure	All except Sleep mode	SPI flag only (FRM)	Write Clear Fault SPI bit FRM	A valid SPI communication

10 Functional block description

10.1 Oscillator

A single clock module is used for all systems and filter timing.

10.1.1 Frequency modulation

The clock is frequency modulated to spread the oscillator's energy over a wide frequency band. This spreading decreases the peak electromagnetic radiation level and improves electromagnetic compatibility (EMC) performance.

Table 23. Frequency electrical characteristics

$V_{PWR} = 5.0\text{ V to }28\text{ V}$, $T_J = -40\text{ }^\circ\text{C to }150\text{ }^\circ\text{C}$, unless otherwise specified.

Symbol	Parameter	Min.	Typ.	Max.	Unit
Oscillator					
f _{osc}	Oscillator frequency	8.277	9.3	10.323	MHz

10.2 Charge pump

10.2.1 Description

The charge pump generates a voltage of 9.5 V nominal/12 V maximum above the V_{PWR} supply. The maximum external load which can be connected to the CCP pin is 20 μA . The charge pump requires an external 20 V capacitor for energy storage and to cover

transients. A SPI flag error is reported when $V_{CP} \leq V_{CP_UV}$. The charge pump frequency is modulated by means of the spread spectrum modulation of the main clock.

Table 24. Charge pump electrical characteristics
 $V_{PWR} = 5.0\text{ V to }28\text{ V}$, $T_J = -40\text{ }^\circ\text{C to }150\text{ }^\circ\text{C}$, unless otherwise specified.

Symbol	Parameter	Min.	Typ.	Max.	Unit
Charge pump					
C_{CP}	Charge pump external capacitor [1]	—	100	—	nF
V_{CP}	Charge pump voltage referenced to V_{PWR} [2]	V_{CP_UV}	9.5	12	V
V_{CP}	Charge pump voltage referenced to V_{PWR} [3]	6.0	—	$(2 \times V_{PWR}) - 1.0$	V
I_{CP}	Charge pump current capability	1.0	—	—	mA
V_{CP_UV}	Charge pump undervoltage threshold	7.45	8.0	8.7	V
$t_{CP_UV_F}$	Charge pump undervoltage detection filter time	—	18.0	—	μs
f_{CP}	Charge pump frequency	—	9.3	—	MHz

[1] A 20 V X7R capacitor with at least $\pm 20\%$ tolerance is recommended.
 [2] With 1.0 mA loading on the charge pump and $8.0\text{ V} \leq V_{PWR} < 28.0\text{ V}$
 [3] With 1.0 mA loading on the charge pump and $5.0\text{ V} \leq V_{PWR} < 8.0\text{ V}$

10.3 VDDQ digital output supply voltage

10.3.1 Description

The VDDQ pin supplies the digital output buffer (MISO) of the MC33HB2001, either at 5.0 V or 3.3 V, by connecting externally to the system MCU supply:

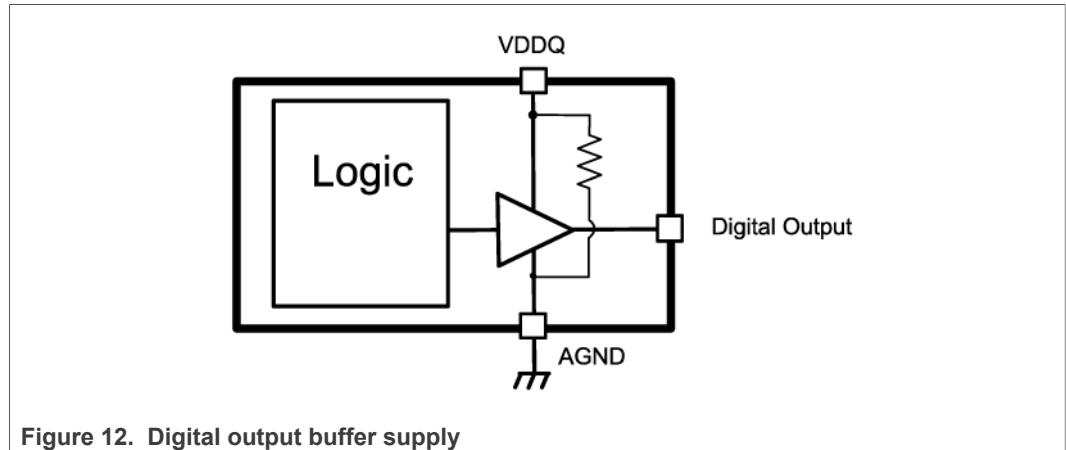

Figure 12. Digital output buffer supply

This pin has a pull-down resistor to ensure the input is low in the event it is left open. If this pin is shorted to ground or left open, the SPI MISO reports 0000h.

Table 25. VDDQ electrical characterizations
 $V_{DDQ} = 3.13\text{ V to }5.25\text{ V}$, $T_J = -40\text{ }^\circ\text{C to }150\text{ }^\circ\text{C}$, unless otherwise specified.

Symbol	Characteristic	Min.	Typ.	Max.	Unit
R_{DOWN_VDDQ}	VDDQ pull-down resistor	55	100	260	k Ω

10.4 H-bridge and Half-bridge operation

10.4.1 Description

The H-bridge output control is defined by the SPI bit.

Half-bridge control

- In parallel mode, the physical inputs IN1 and IN2 control the OUT1 and OUT2 respectively
- In SPI mode, VIN1 and VIN2 control the Half-bridge outputs similar to physical inputs

H-bridge control

- In parallel mode, the physical input IN1 controls direction and IN2 controls PWM
- In SPI mode, VIN1 and VIN2 control the H-Bridge outputs similar to physical inputs

This device provides active recirculation through the opposing FET of each Half-bridge. Embedded protections avoid cross conduction. In Half-bridge mode, active current limit, overvoltage protection, and open load detection features are disabled. For overvoltage, there is OV warning only. Moreover, unlike H-bridge control mode, the short-circuit protection acts independently on each output.

A more detailed explanation of output characteristic with respect to inputs in H-bridge as well as Half-bridge mode is explained in [Section 9.7.4 "Truth table"](#). The differences in fault priorities between the two modes is described in section [Section 10.4.1.1 "H-bridge and Half-bridge fault priority"](#).

10.4.1.1 H-bridge and Half-bridge fault priority

The following tables specify which fault control dominates output control if two or more are present at one time. Note that for these tables ENBL and DIS are defined as the signal condition which disables the output. EN is the SPI control bit setting which disables the outputs.

Table 26. H-Bridge mode fault priority

	OT	OC	SCG1	SCG2	SCP1	SCP2	OV	UV	ENBL	DIS
OC	OT									
SCG1	SC	SC								
SCG2	SC	SC	SC							
SCP1	OT	SC	SC	SC						
SCP2	OT	SC	SC	SC	SC					
OV	OT	OV	SC	SC	OV	OV				
UV	UV	UV	UV	UV	UV	UV	UV			
ENBL	ENBL	ENBL	ENBL	ENBL	ENBL	ENBL	ENBL	ENBL		
DIS	DIS	DIS	DIS	DIS	DIS	DIS	OV	DIS	ENBL	
EN	EN	EN	EN	EN	EN	EN	OV	UV	ENBL	DIS

Table 27. Half-bridge mode fault priority

	OT	SCG1	SCG2	SCP1	SCP2	UV	ENBL	DIS
SCG1	OT							
SCG2	OT	SC1 AND 2						
SCP1	OT	SC1	SC1 AND 2					
SCP2	OT	SC1 AND 2	SC2	SC1 AND 2				
UV	UV	UV	UV	UV	UV			
ENBL	ENBL	ENBL	ENBL	ENBL	ENBL	ENBL		
DIS	DIS	DIS	DIS	DIS	DIS	DIS	ENBL	
EN	EN	EN	EN	EN	EN	UV	ENBL	DIS

Table 28. Fault priority description

Name	Description
OT	Overtemperature
OC	Overcurrent
SC	Short-circuit
SCGx	Short to ground
SCPx	Short to power (VPWR)
OV	Overvoltage
UV	Undervoltage

10.4.1.2 Current recopy

High-side FETs have current recopy feature. Current recopy has less than 5 % error referred to the load, for currents between 2.0 A and 10 A. Current recopy is a ratio of 1/400 of the current through the FET. This recopy current is made available on the CFB pin.

10.4.1.3 Slew rate selection

The slew rate is selectable by SPI bits from 0.25 V/μs to 16 V/μs. There is a bypass setting which switches the outputs as fast as possible.

10.4.1.4 Active current limit regulation

[Figure 13](#) presents the simplified current regulation loop.

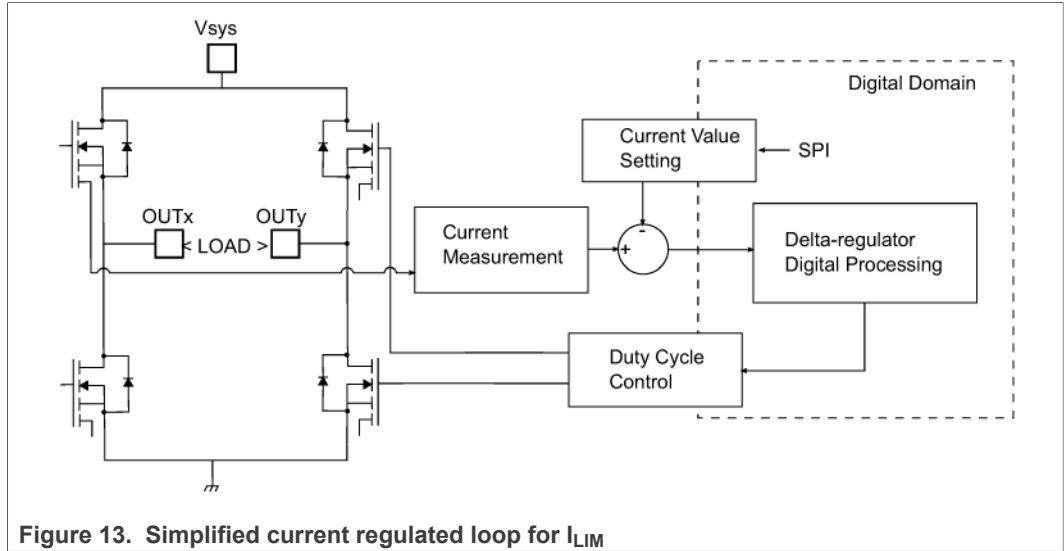
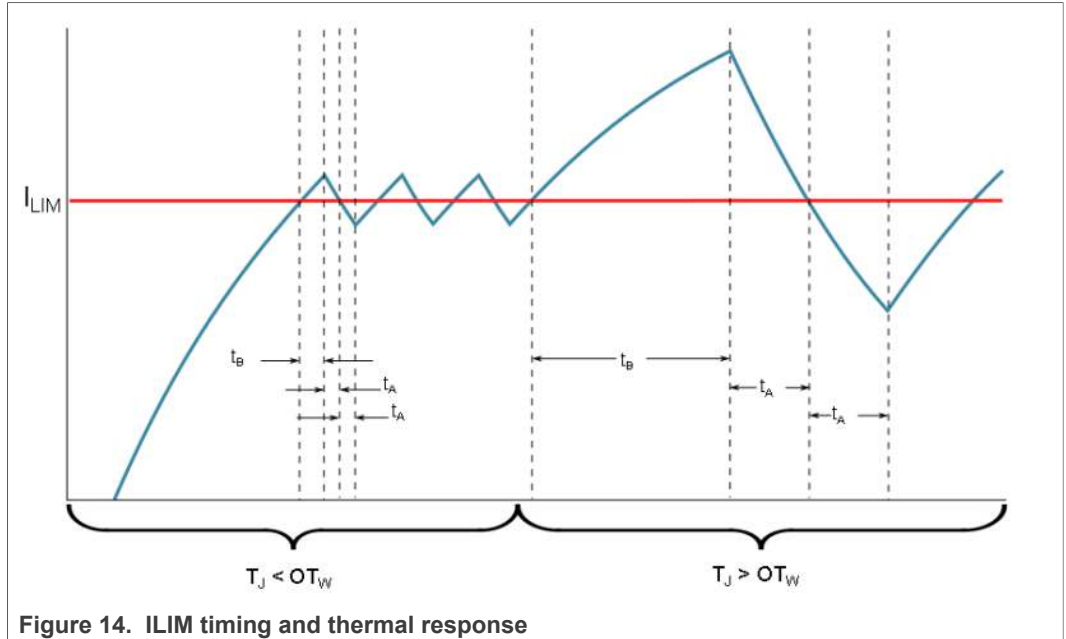

Figure 13. Simplified current regulated loop for I_{LIM}

The active current limit threshold is selectable by the SPI in four steps from 5.0 A to 10 A. The active current limit is initiated, and the OC SPI fault status bit is set when the current exceeds the threshold set by the current limit comparator.

A blanking time (t_B , 32 μ s) is set from the time the current limit is exceeded. If a short-circuit shutdown is not triggered before the blanking time has expired, the H-bridge switches to high-side recirculation mode for $2 * t_A$. t_A is determined by the time it takes for the current to decay below the current limit threshold after switching to recirculation mode.

After $2 * t_A$, the control of the gates releases, restoring the output to the configuration set by the inputs. If the average output FET temperature exceeds the die temperature warning threshold (OT_W), the blanking time (t_B) increases by a factor of 8 (256 μ s), effectively decreasing the current limit PWM frequency. The temperature dependent blanking time does not change during the blanking interval. Input control does not cause the output to switch ON while current is greater than I_{LIM} . Input control commanding the output to switch OFF immediately switches OFF the output and resets the I_{LIM} circuit.



10.4.1.5 Open load detection in standby mode

This diagnostic only operates when the device is in Standby mode (both outputs in a high-impedance state) and is configured for full H-bridge mode. It is designed for applications having less than 50 nF from OUT1 and OUT2 to GND, a load inductance less than 15 mH, and an equivalent resistance of 600 Ω (typical) as a target for open load detection.

The diagnostic can activate in one of two ways:

1. The device is transitioning from STBY mode to Normal mode and the CL bit is high.
2. The device is in STBY mode and receives a command changing the CL bit setting from low to high.

When the open load check is performed, if there is current in an inductive load at the start of the test, the results may not be valid.

The diagnostic is activated in two stages:

1. The circuit turns on both low-side output FETs, to discharge any residual charge on the output capacitance. During this stage, the short-circuit detection for OUT1 or OUT2 is functional and provides normal short-circuit protection and diagnostics.
2. In second stage, the circuit turns off the OUT1 low-side FET and applies an internal pull-up of 1.0 mA on OUT1 while maintaining the OUT2 low-side driver on. If the voltage on OUT1 is greater than the open load threshold after the defined filter time, an open load fault is recorded. See [Figure 15](#) for more details. The OUT1 and OUT2 are restored to the commanded configuration after the test results are latched into the fault buffer.

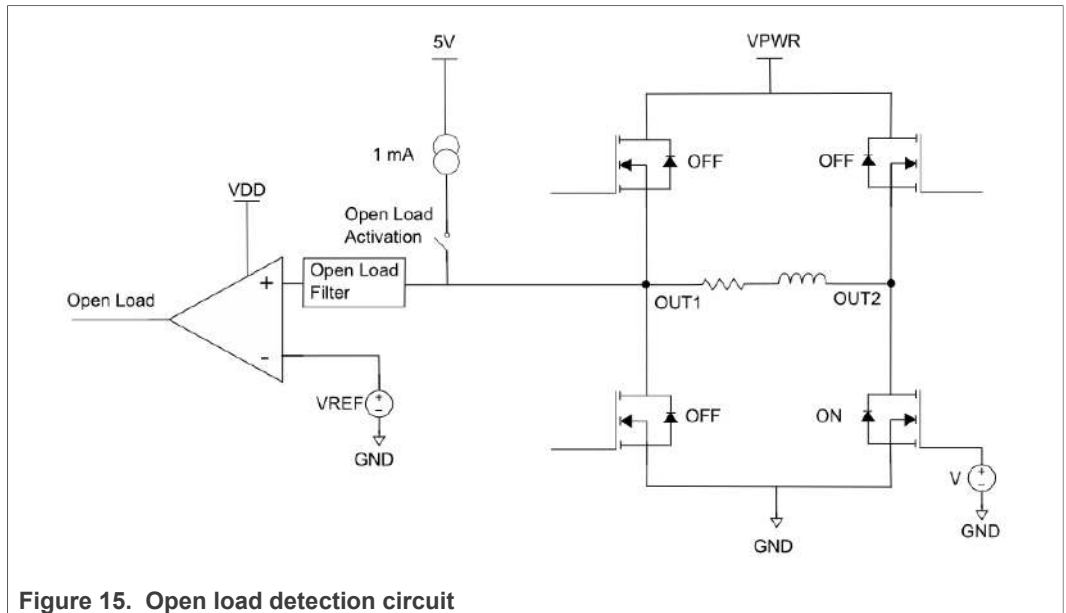

Figure 15. Open load detection circuit

10.4.1.6 Open load detection in active mode

Open load detection in Active mode is active when the output is configured for full H-Bridge mode and an output is being switched. Open load in Active mode is detected when the OUT1 and OUT2 voltages do not exhibit overshoot greater than the V_{OLATH} (threshold) over V_{PWR} between the time the low-side is commanded OFF and the low-side FET is turned back on during an output PWM cycle, as shown in Figure 16 and Figure 17. On the other hand, an open load is not detected if the energy stored in the inductor is high enough to cause an overshoot greater than the V_{OLATH} (threshold) over V_{PWR} caused by the fly-back current flowing through the body diode, as shown in anti-shoot through phase of Figure 16.

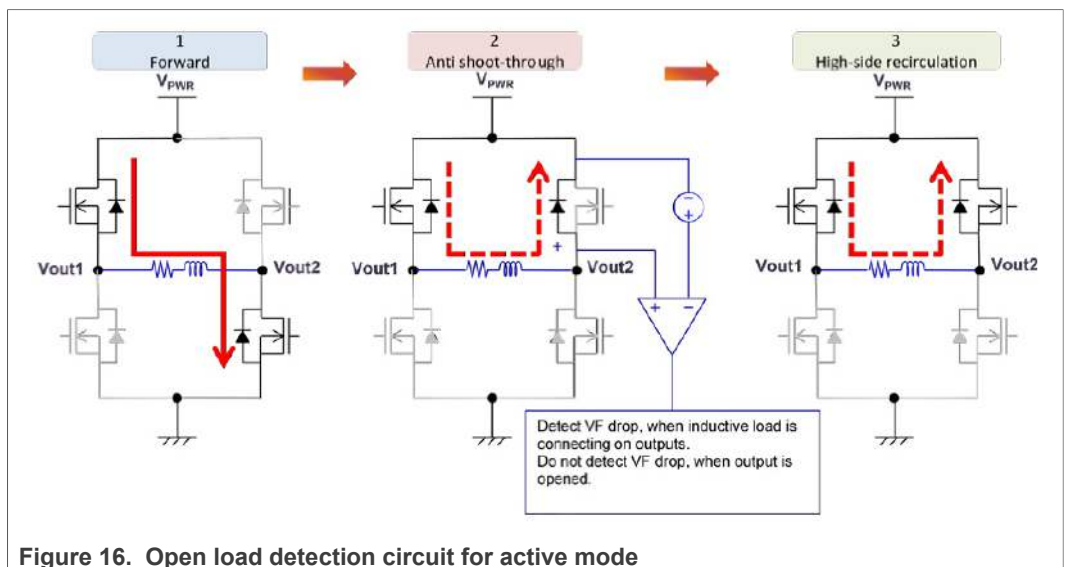

Figure 16. Open load detection circuit for active mode

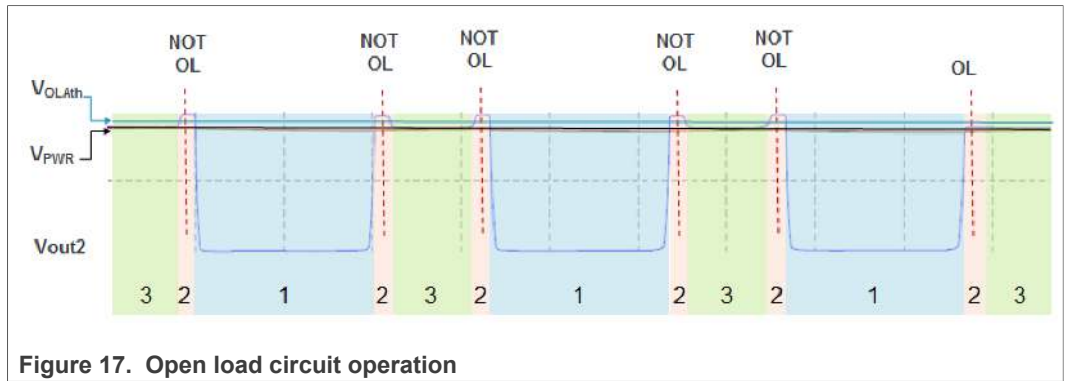

Figure 17. Open load circuit operation

During normal operation, the result of the open load detection window is held until the end of the next detection window. Open load detected in the active mode is a dynamic status which is only cleared by detecting the load is not open or leaving Normal mode.

10.4.1.7 Short-circuit detection

The short-circuit detection circuit monitors both high-side and low-side FETs continuously. When the current is above the short-circuit threshold (SC) for the defined filter time (t_{SC}), the driver is switched off, and the SPI fault bit is set. The driver can be restored to normal operation by clearing the fault status by performing `clrflt`, as described in [Section 9.6.3.1 "Clearing the fault status"](#).

10.4.2 Electrical characteristics

Table 29. H-bridge electrical characterization
 $V_{PWR} = 5.0\text{ V to }28\text{ V}$, $T_J = -40\text{ }^\circ\text{C to }150\text{ }^\circ\text{C}$, unless otherwise specified.

Symbol	Parameter	Min.	Typ.	Max.	Unit
OUTPUT					
$R_{DS(ON_LSD)}$	LSDx on-state resistance, $I_{LDS} = 3.0\text{ A}$, $T_J = 150\text{ }^\circ\text{C}$ [1]	—	90	125	m Ω
$R_{DS(ON_LSD)}$	LSDx on-state resistance, $I_{LDS} = 3.0\text{ A}$, $T_J = -40\text{ }^\circ\text{C}$ [1] [2]	—	45	80	m Ω
$R_{DS(ON_HSD)}$	HSDx on-state resistance, $I_{LDS} = 3.0\text{ A}$, $T_J = 150\text{ }^\circ\text{C}$ [1]	—	100	125	m Ω
$R_{DS(ON_HSD)}$	HSDx on-state resistance, $I_{LDS} = 3.0\text{ A}$, $T_J = -40\text{ }^\circ\text{C}$ [1] [2]	—	50	80	m Ω
V_F	Output MOSFET body diode forward voltage drop with $I_{LDS} = 3.0\text{ A}$	—	—	2.0	V
t_{DON} t_{DOFF}	OUTx turn-on and turn-off delay times Digital signal to 10 % or 90 % $I_{LOAD} = 1.0\text{ A}$, $V_{PWR} = 14\text{ V}$, SR = "000", resistive load	—	—	3.0	μs
$t_{DDISABLE}$	OUTx disable delay time	—	—	3.0	μs
$t_{RDISABLE_1}$	OUTx disable recovery delay time Open load detection disabled, DIS recovery after 1.0 μs high or ENBL recovery after 5.0 μs low, SR = "000", resistive load < 400 Ω	—	—	8.0	μs
$t_{RDISABLE_2}$	OUTx disable recovery delay time Open load detection enabled, DIS recovery after 1.0 μs high or ENBL recovery after 5.0 μs low, SR = "000", resistive load < 400 Ω	—	—	128	μs

10 A H-bridge, SPI programmable brushed DC motor driver

Table 29. H-bridge electrical characterization...continued

 $V_{PWR} = 5.0\text{ V to }28\text{ V}$, $T_J = -40\text{ }^\circ\text{C to }150\text{ }^\circ\text{C}$, unless otherwise specified.

Symbol	Parameter	Min.	Typ.	Max.	Unit
SR	OUTx rising and falling slew rate, from 10 % to 90 % of V_{PWR} , measured with 1.0 A resistive load at $V_{PWR} = 14\text{ V}$				
	SPI SR = 000	—	bypass	—	V/ μ s
	SPI SR = 001	11.2	16	20.8	
	SPI SR = 010	5.6	8.0	10.4	
	SPI SR = 011	2.8	4.0	5.2	
	SPI SR = 100 (default)	1.4	2.0	2.6	
	SPI SR = 101	0.7	1.0	1.3	
	SPI SR = 110	0.35	0.5	0.65	
	SPI SR = 111	0.15	0.25	0.35	
CURRENT SENSE					
I_{RATIO}	Current recopy ratio				
	$I_{LOAD} < 2.0\text{ A}$ $2.0\text{ A} \leq I_{LOAD} < 10\text{ A}$	— —	2.5 2.5	— —	mA/A
I_{ERROR}	Load current error, $I_{LOAD} < 2.0\text{ A}$	-0.100	—	0.100	A
I_{ERROR}	Load current error, $2.0\text{ A} \leq I_{LOAD} < 10\text{ A}$	-5.0	—	5.0	%
dI/dt	Load current slew rate	0.5	—	—	A/ μ s
FAULT DETECTION AND CURRENT LIMIT REGULATION					
I_{LIM}	Current limit threshold current				
	SPI ILIM = 00	4.0	5.4	6.8	A
	SPI ILIM = 01 (default)	6.0	7.0	8.0	
	SPI ILIM = 10	7.3	8.8	10.3	
	SPI ILIM = 11	9.0	10.7	12.5	
t_B	Blanking time				
	$T_J < OT_W$ $T_J \geq OT_W$	— —	32 256	— —	μ s
SHORT-CIRCUIT SHUTDOWN					
I_{SC_LS}	Low-side short-circuit detection threshold current	$I_{LIM} + 3.0$	—	$I_{LIM} + 8.0$	A
I_{SC_HS}	High-side short-circuit detection threshold current	$I_{LIM} + 4.0$	—	$I_{LIM} + 9.0$	A
t_{SC}	Short-circuit detection filter time	5.0	—	10	μ s
OPEN LOAD DETECTION					
V_{OP}	Open load detection voltage threshold	0.6	—	0.8	V
I_{OL}	Out1 pull-up current	0.8	—	1.3	mA
t_{OP_LSD}	Open load detection filter time	93	—	118	μ s
V_{OLATH}	Open load active mode threshold $V_{OLA} = V_{OUTx} - V_{PWR}$	160	—	360	mV

[1] In an application, $R_{DS(on)}$ depends on charge pump loading and timing limitations, including slew rate and duty cycle. These factors determine the enhancement level of the device's integrated high-side FETs during switching.

[2] Guaranteed by characterization

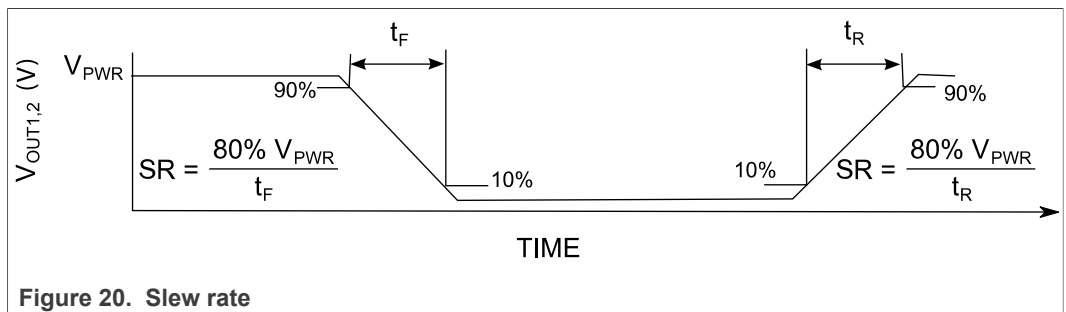
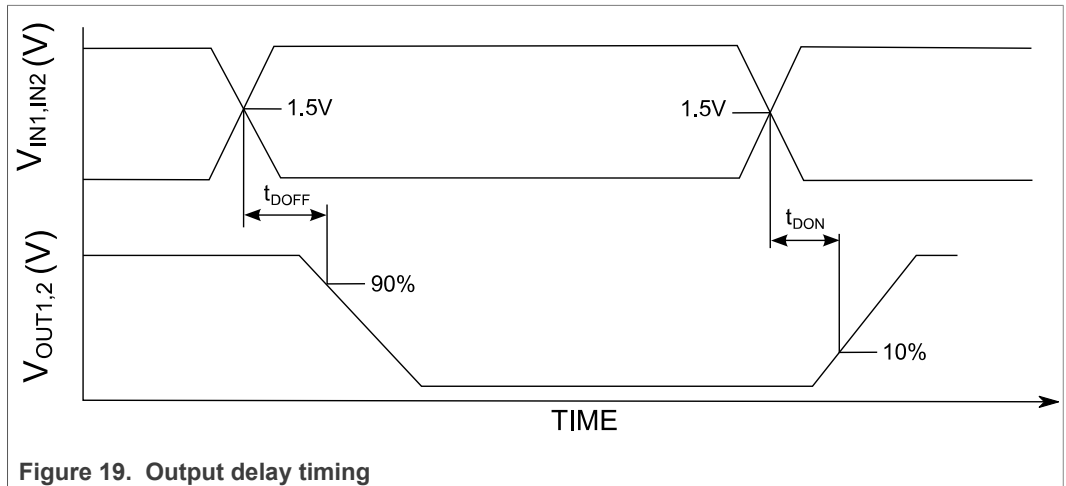
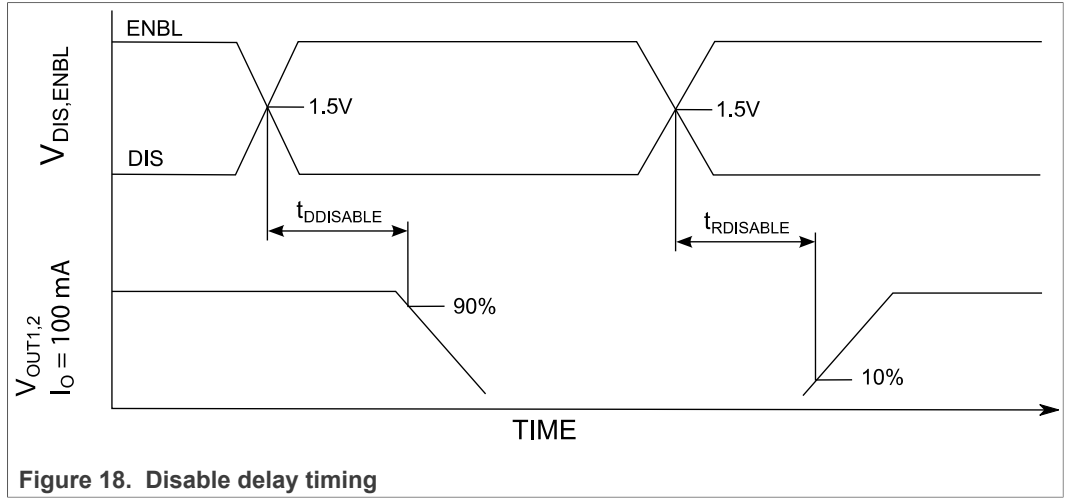

11 Applications

11.1 Introduction

The MC33HB2001 is a programmable and configurable H-bridge, power integrated circuit (IC) designed to drive DC motors or bi-directional solenoid controlled actuators, such as throttle control or exhaust gas recirculation actuators, with continuous average current of

3.0 A and peaks over 10.0 A. [Figure 21](#) shows a typical simplified minimum application schematic without SPI interface to MCU and reverse battery protection through a diode. [Figure 22](#) shows a typical simplified application diagram with reverse battery protection using an external N-channel FET driven by the CCP pin. This is useful for low battery voltage applications where diode drops could be significant. See [Section 8.3.1 "Reverse battery"](#) for details on reverse battery protection.

The value of C1 is determined based on the maximum current in the load, and the maximum system voltage. C1 should be able to absorb this energy without exceeding 40 V, otherwise a clamp is required, as explained in [Section 11.3 "Output avalanche protection"](#). If ENBL is high and the part is in H-bridge mode, the OV protection protects against this condition.

11.2 Application diagram

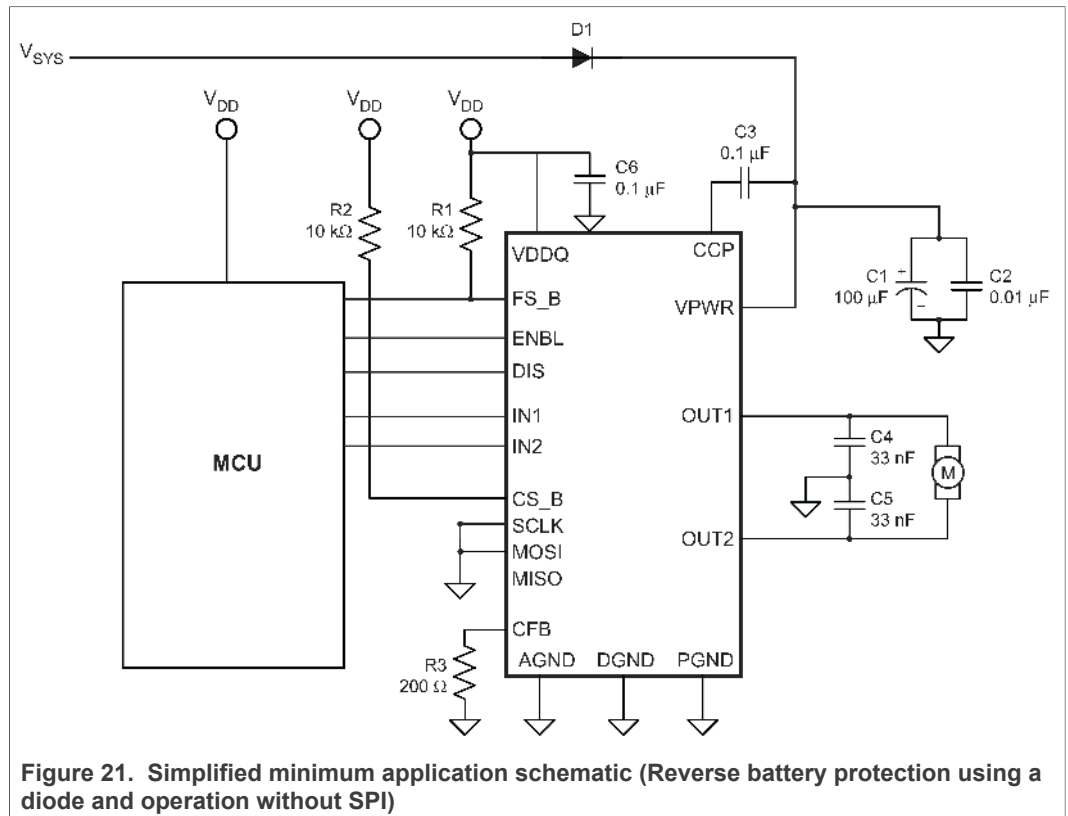

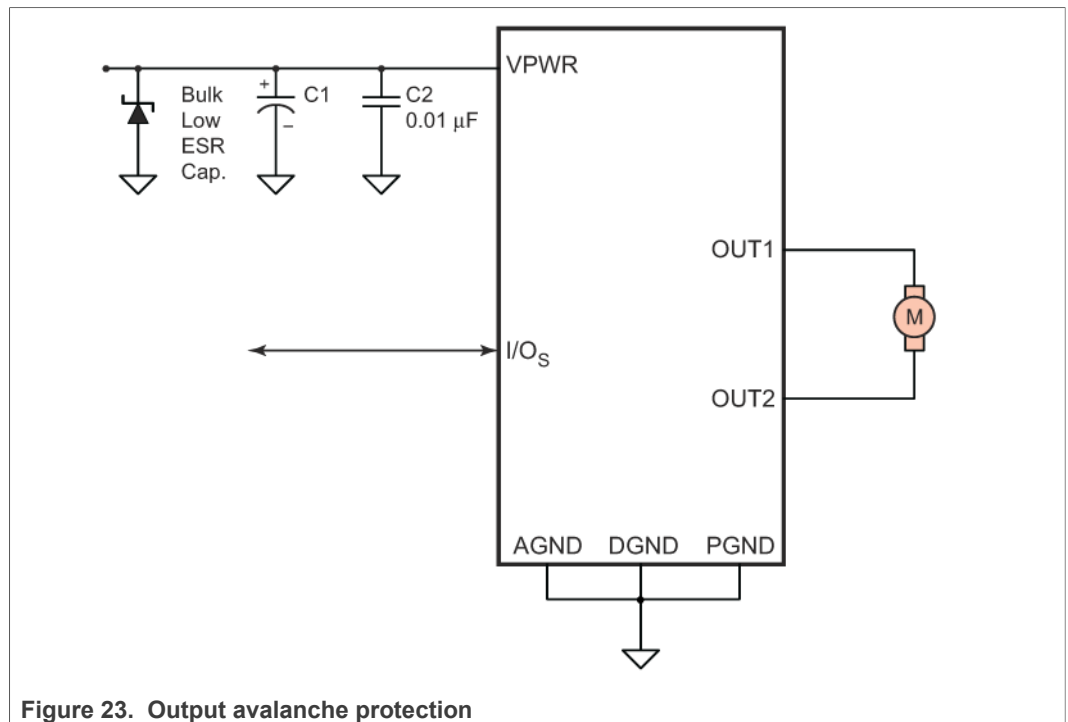

Figure 23. Output avalanche protection

12 Packaging

12.1 Package mechanical dimensions

Package dimensions are provided in package drawings. To find the most current package outline drawing, go to www.nxp.com and perform a keyword search for the drawing's document number.

Table 30. Package outline

Package	Suffix	Package outline drawing number
32-pin SOICW-EP	EK	98ARL10543D
32-pin PQFN	FK	98ARL10579D

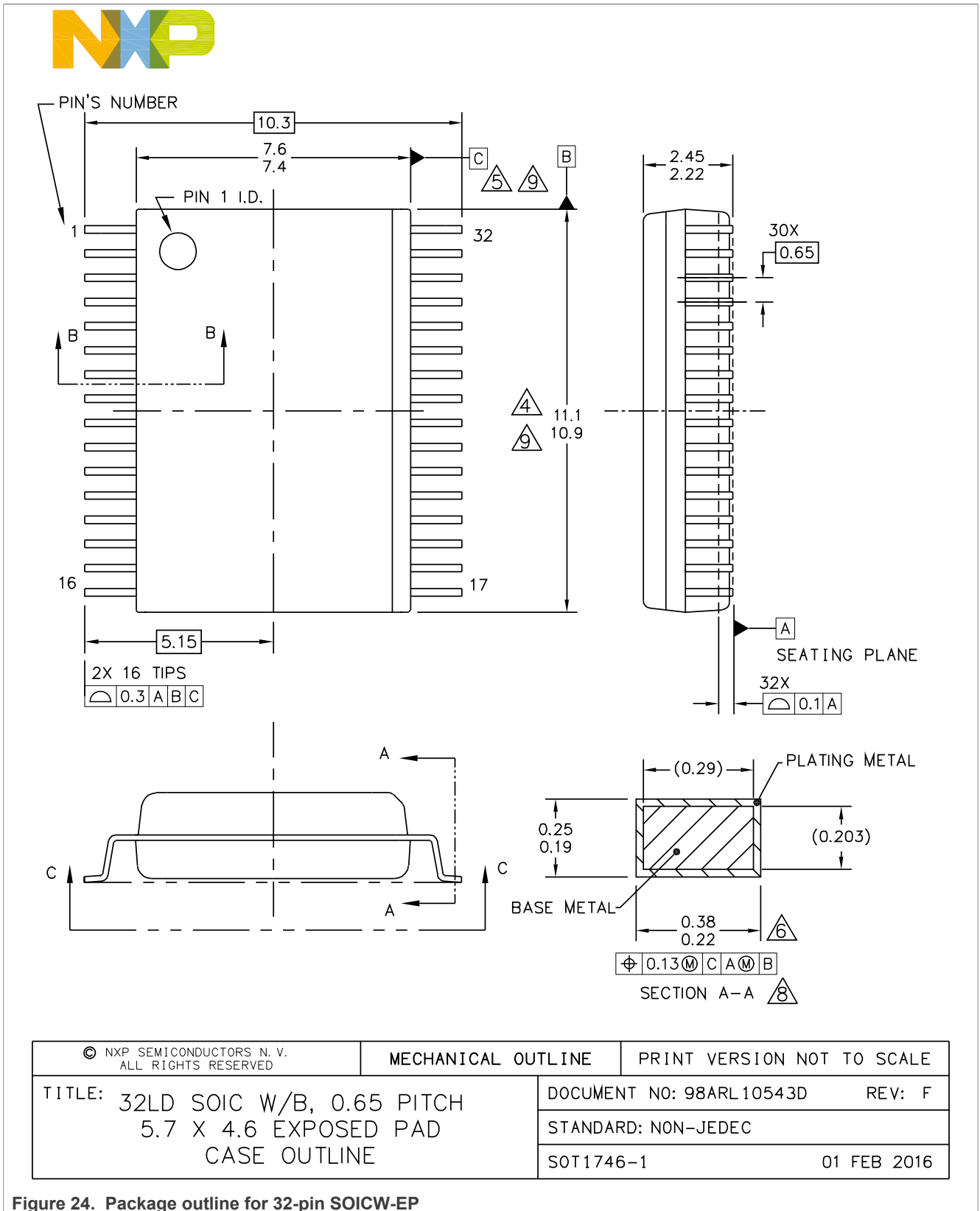

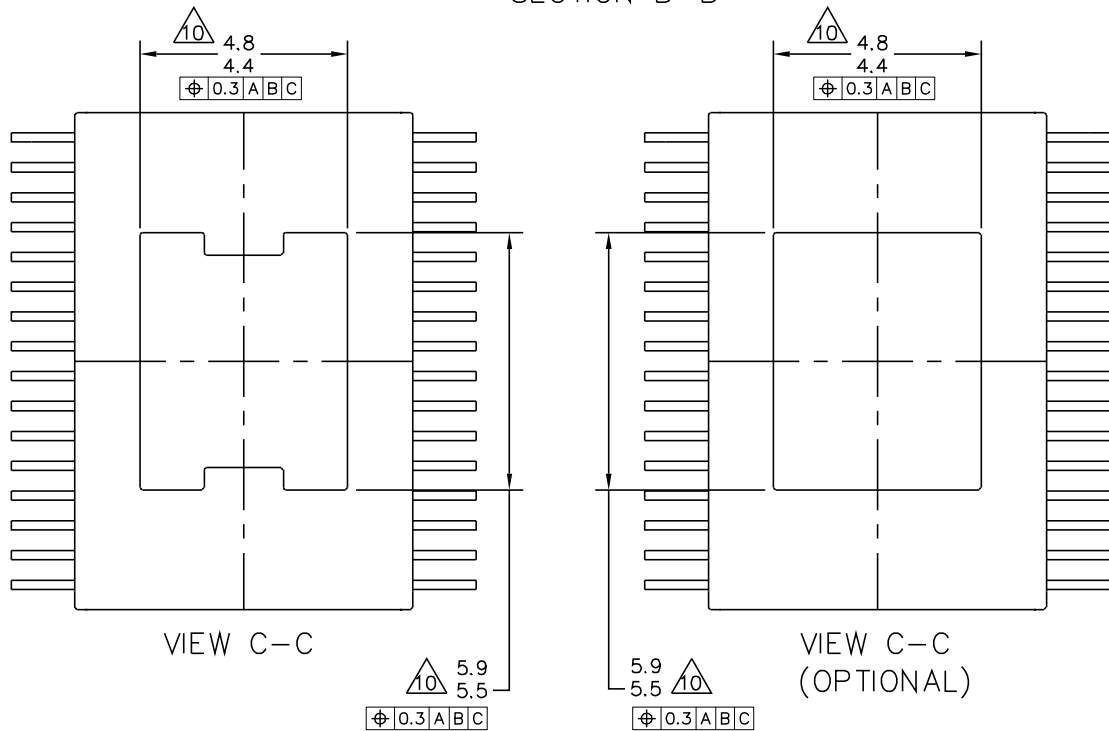
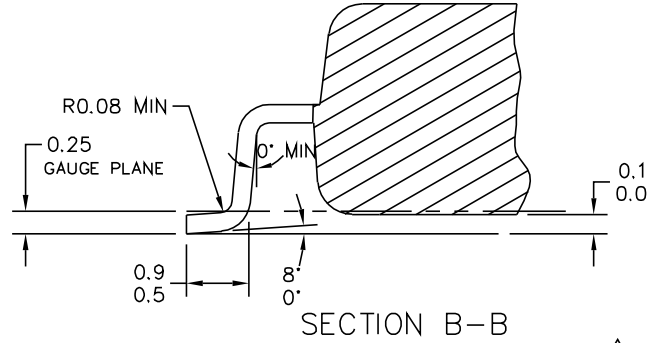

© NXP SEMICONDUCTORS N. V. ALL RIGHTS RESERVED	MECHANICAL OUTLINE	PRINT VERSION NOT TO SCALE
TITLE: 32LD SOIC W/B, 0.65 PITCH 5.7 X 4.6 EXPOSED PAD CASE OUTLINE	DOCUMENT NO: 98ARL10543D	REV: F
	STANDARD: NON-JEDEC	
	SOT1746-1	01 FEB 2016

Figure 25. Package outline detail for 32-pin SOICW-EP



NOTES:

1. DIMENSIONS ARE IN MILLIMETERS.
2. DIMENSIONING AND TOLERANCING PER ASME Y14.5M-1994.
3. DATUMS B AND C TO BE DETERMINED AT THE PLANE WHERE THE BOTTOM OF THE LEADS EXIT THE PLASTIC BODY.
4. THIS DIMENSION DOES NOT INCLUDE MOLD FLASH, PROTRUSION OR GATE BURRS. MOLD FLASH, PROTRUSION OR GATE BURRS SHALL NOT EXCEED 0.15 MM PER SIDE. THIS DIMENSION IS DETERMINED AT THE PLANE WHERE THE BOTTOM OF THE LEADS EXIT THE PLASTIC BODY.
5. THIS DIMENSION DOES NOT INCLUDE INTER-LEAD FLASH OR PROTRUSIONS. INTER-LEAD FLASH AND PROTRUSIONS SHALL NOT EXCEED 0.25 MM PER SIDE. THIS DIMENSION IS DETERMINED AT THE PLANE WHERE THE BOTTOM OF THE LEADS EXIT THE PLASTIC BODY.
6. THIS DIMENSION DOES NOT INCLUDE DAMBAR PROTRUSION. ALLOWABLE DAMBAR PROTRUSION SHALL NOT CAUSE THE LEAD WIDTH TO EXCEED 0.4 mm. DAMBAR CANNOT BE LOCATED ON THE LOWER RADIUS OR THE FOOT. MINIMUM SPACE BETWEEN PROTRUSION AND ADJACENT LEAD SHALL NOT LESS THAN 0.07 mm.
7. EXACT SHAPE OF EACH CORNER IS OPTIONAL.
8. THESE DIMENSIONS APPLY TO THE FLAT SECTION OF THE LEAD BETWEEN 0.10 mm AND 0.3 mm FROM THE LEAD TIP.
9. THE PACKAGE TOP MAY BE SMALLER THAN THE PACKAGE BOTTOM. THIS DIMENSION IS DETERMINED AT THE OUTERMOST EXTREMES OF THE PLASTIC BODY EXCLUSIVE OF MOLD FLASH, TIE BAR BURRS, GATE BURRS AND INTER-LEAD FLASH, BUT INCLUDING ANY MISMATCH BETWEEN THE TOP AND BOTTOM OF THE PLASTIC BODY.
10. THESE DIMENSIONS RANGES DEFINE THE PRIMARY KEEP-OUT AREA. MOLD LOCKING AND RESIN BLEED CONTROL FEATURES MAY BE VISIBLE AND THEY MAY EXTEND TO 0.9mm FROM MAXIMUM EXPOSED PAD SIZE

© NXP SEMICONDUCTORS N. V. ALL RIGHTS RESERVED	MECHANICAL OUTLINE	PRINT VERSION NOT TO SCALE
TITLE: 32LD SOIC W/B, 0.65 PITCH 5.7 X 4.6 EXPOSED PAD CASE OUTLINE	DOCUMENT NO: 98ARL10543D	REV: F
	STANDARD: NON-JEDEC	
	SOT1746-1	01 FEB 2016

Figure 26. Package outline notes for 32-pin SOICW-EP

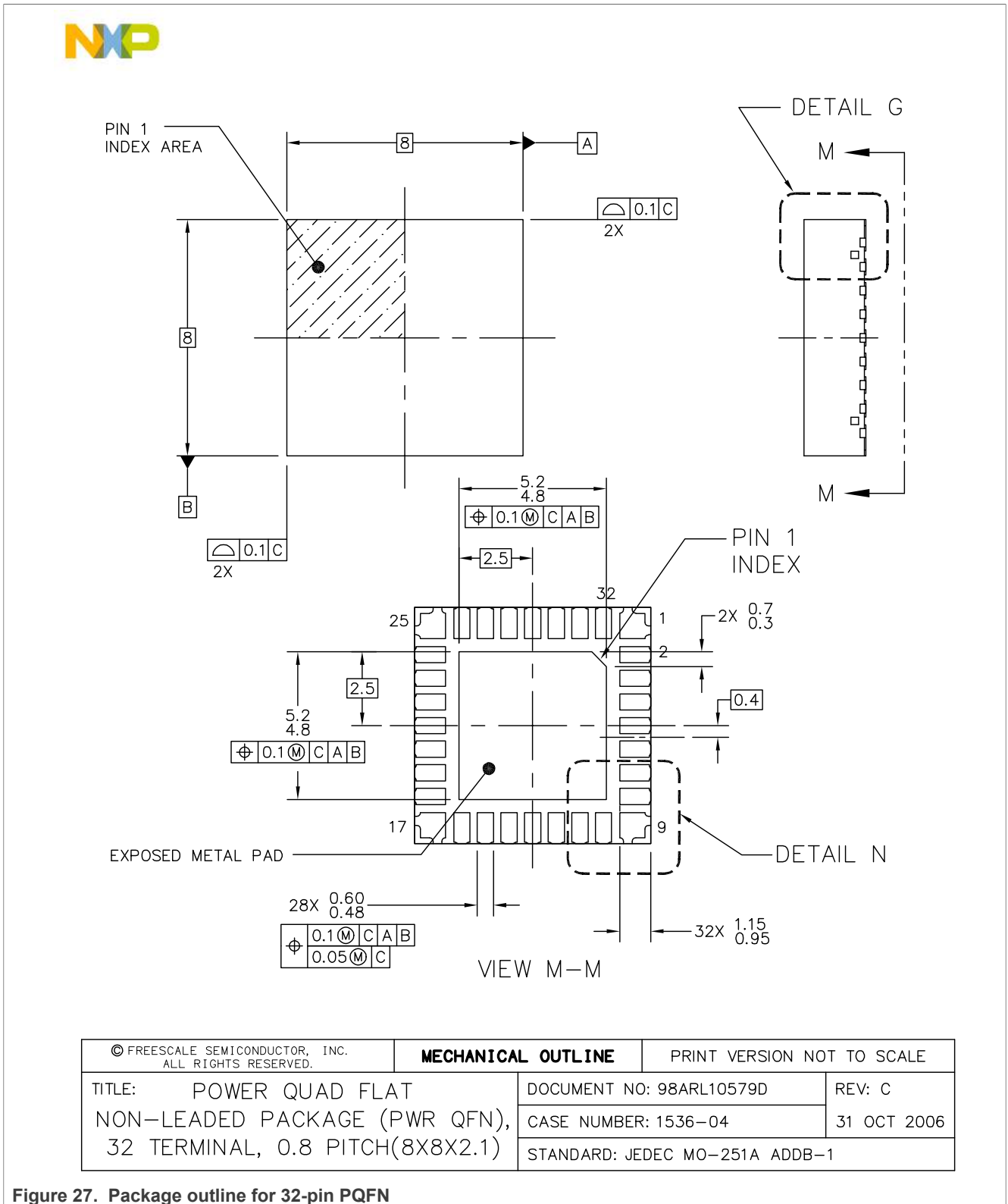

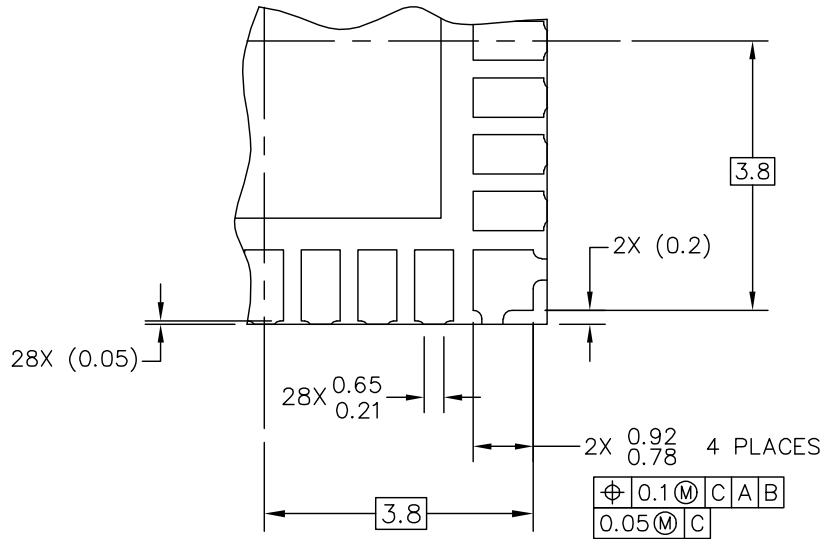

DETAIL N
CORNER CONFIGURATION

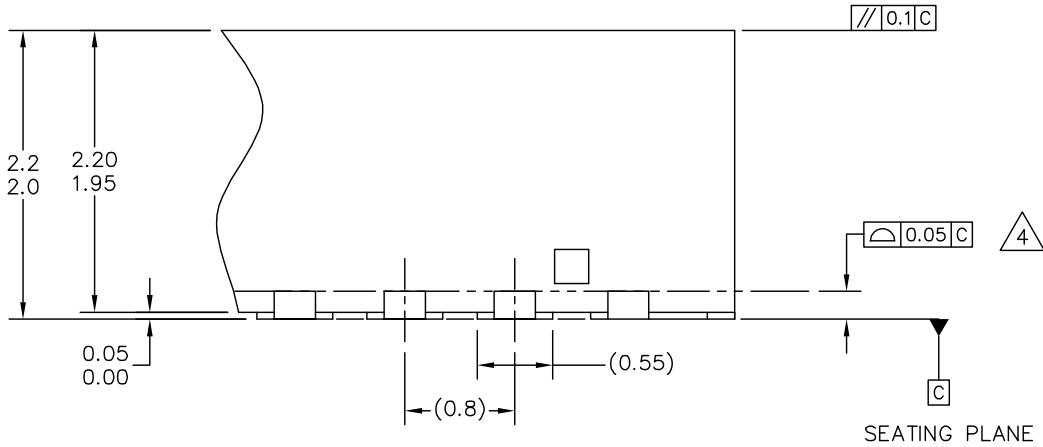

DETAIL G
VIEW ROTATED 90° CW

© FREESCALE SEMICONDUCTOR, INC. ALL RIGHTS RESERVED.	MECHANICAL OUTLINE	PRINT VERSION NOT TO SCALE	
TITLE: POWER QUAD FLAT NON-LEADED PACKAGE (PWR QFN), 32 TERMINAL, 0.8 PITCH(8X8X2.1)	DOCUMENT NO: 98ARL10579D	REV: C	
	CASE NUMBER: 1536-04	31 OCT 2006	
	STANDARD: JEDEC MO-251A ADDB-1		

Figure 28. Package outline detail for 32-pin PQFN



NOTES:

1. ALL DIMENSIONS ARE IN MILLIMETERS.
2. DIMENSIONING AND TOLERANCING PER ASME Y14.5M-1994.
3. THE COMPLETE JEDEC DESIGNATOR FOR THIS PACKAGE IS: F-PQFP-N.
4.  COPLANARITY APPLIES TO LEADS AND CORNER LEADS.
5. MINIMUM METAL GAP SHOULD BE 0.25MM.

© FREESCALE SEMICONDUCTOR, INC. ALL RIGHTS RESERVED.	MECHANICAL OUTLINE	PRINT VERSION NOT TO SCALE	
TITLE: POWER QUAD FLAT NON-LEADED PACKAGE (PWR QFN), 32 TERMINAL, 0.8 PITCH(8X8X2.1)	DOCUMENT NO: 98ARL10579D	REV: C	
	CASE NUMBER: 1536-04	31 OCT 2006	
	STANDARD: JEDEC MO-251A ADDB-1		

Figure 29. Package outline notes for 32-pin PQFN

13 Revision history

Revision	Date	Description of changes
1.0	7/2014	<ul style="list-style-type: none"> Initial release
2.0	10/2014	<ul style="list-style-type: none"> Current limit thresholds modified as per changes in the design Selectable slew rates modified as per changes in design Updated Section 10.4.1.5 "Open load detection in standby mode" Added fault priorities for H-Bridge and Half-Bridge mode Updated the values for slew rate, current limit thresholds, pull-up and pull-down resistors, detection thresholds of diagnostics based on initial qualification characterization Updated application diagrams
3.0	7/2015	<ul style="list-style-type: none"> Changed the priority of fault based on safety requirement Added VDDQ decoupling capacitor in application diagram Modified the VPWR UV Falling lower limit and removed rising specification as it is redundant to the falling spec with hysteresis Added open load detection feature in active/normal operation mode as per new silicon Changed the I/O max. rating to 36V as per the new silicon Added feature of disabling the OV protection feature based on new silicon Added VPWR_POR specification Corrected the disable delay time specification Modified the oscillator frequency, tolerance and charge pump UV specification as per the design requirement
4.0	11/2015	<ul style="list-style-type: none"> Updated the ILIM and Short circuit thresholds
5.0	2/2016	<ul style="list-style-type: none"> Added thermal resistance data Added the specification for forward voltage drop for the output FET body diode Updated document format and style
6.0	5/2016	<ul style="list-style-type: none"> Updated oscillator frequency in Table 23 Updated open load detection filter time in Table 29 Updated charge pump frequency in Table 24 Updated max. value for 33HB2001EK Junction to Package Top - Natural Convection Ψ_{JT} in Table 4 Updated document format and style
7.0	10/2017	<ul style="list-style-type: none"> Added note in Section 9.6.1 "Description" as per CIN 2017090351
8.0	6/2018	<ul style="list-style-type: none"> Updated Table 29 (added typical ratings for $R_{DS(on)}$)
9.0	8/2018	<ul style="list-style-type: none"> Added AEC-Q100 grade 1 qualified to Section 1 and Section 3
10.0	10/2020	<ul style="list-style-type: none"> Changed data sheet status to Product, CIN# 2020100351

14 Legal information

14.1 Data sheet status

Document status ^{[1][2]}	Product status ^[3]	Definition
Objective [short] data sheet	Development	This document contains data from the objective specification for product development.
Preliminary [short] data sheet	Qualification	This document contains data from the preliminary specification.
Product [short] data sheet	Production	This document contains the product specification.

[1] Please consult the most recently issued document before initiating or completing a design.

[2] The term 'short data sheet' is explained in section "Definitions".

[3] The product status of device(s) described in this document may have changed since this document was published and may differ in case of multiple devices. The latest product status information is available on the Internet at URL <http://www.nxp.com>.

14.2 Definitions

Draft — A draft status on a document indicates that the content is still under internal review and subject to formal approval, which may result in modifications or additions. NXP Semiconductors does not give any representations or warranties as to the accuracy or completeness of information included in a draft version of a document and shall have no liability for the consequences of use of such information.

Short data sheet — A short data sheet is an extract from a full data sheet with the same product type number(s) and title. A short data sheet is intended for quick reference only and should not be relied upon to contain detailed and full information. For detailed and full information see the relevant full data sheet, which is available on request via the local NXP Semiconductors sales office. In case of any inconsistency or conflict with the short data sheet, the full data sheet shall prevail.

Product specification — The information and data provided in a Product data sheet shall define the specification of the product as agreed between NXP Semiconductors and its customer, unless NXP Semiconductors and customer have explicitly agreed otherwise in writing. In no event however, shall an agreement be valid in which the NXP Semiconductors product is deemed to offer functions and qualities beyond those described in the Product data sheet.

14.3 Disclaimers

Limited warranty and liability — Information in this document is believed to be accurate and reliable. However, NXP Semiconductors does not give any representations or warranties, expressed or implied, as to the accuracy or completeness of such information and shall have no liability for the consequences of use of such information. NXP Semiconductors takes no responsibility for the content in this document if provided by an information source outside of NXP Semiconductors. In no event shall NXP Semiconductors be liable for any indirect, incidental, punitive, special or consequential damages (including - without limitation - lost profits, lost savings, business interruption, costs related to the removal or replacement of any products or rework charges) whether or not such damages are based on tort (including negligence), warranty, breach of contract or any other legal theory. Notwithstanding any damages that customer might incur for any reason whatsoever, NXP Semiconductors' aggregate and cumulative liability towards customer for the products described herein shall be limited in accordance with the Terms and conditions of commercial sale of NXP Semiconductors.

Right to make changes — NXP Semiconductors reserves the right to make changes to information published in this document, including without limitation specifications and product descriptions, at any time and without

notice. This document supersedes and replaces all information supplied prior to the publication hereof.

Applications — Applications that are described herein for any of these products are for illustrative purposes only. NXP Semiconductors makes no representation or warranty that such applications will be suitable for the specified use without further testing or modification. Customers are responsible for the design and operation of their applications and products using NXP Semiconductors products, and NXP Semiconductors accepts no liability for any assistance with applications or customer product design. It is customer's sole responsibility to determine whether the NXP Semiconductors product is suitable and fit for the customer's applications and products planned, as well as for the planned application and use of customer's third party customer(s). Customers should provide appropriate design and operating safeguards to minimize the risks associated with their applications and products. NXP Semiconductors does not accept any liability related to any default, damage, costs or problem which is based on any weakness or default in the customer's applications or products, or the application or use by customer's third party customer(s). Customer is responsible for doing all necessary testing for the customer's applications and products using NXP Semiconductors products in order to avoid a default of the applications and the products or of the application or use by customer's third party customer(s). NXP does not accept any liability in this respect.

Limiting values — Stress above one or more limiting values (as defined in the Absolute Maximum Ratings System of IEC 60134) will cause permanent damage to the device. Limiting values are stress ratings only and (proper) operation of the device at these or any other conditions above those given in the Recommended operating conditions section (if present) or the Characteristics sections of this document is not warranted. Constant or repeated exposure to limiting values will permanently and irreversibly affect the quality and reliability of the device.

Terms and conditions of commercial sale — NXP Semiconductors products are sold subject to the general terms and conditions of commercial sale, as published at <http://www.nxp.com/profile/terms>, unless otherwise agreed in a valid written individual agreement. In case an individual agreement is concluded only the terms and conditions of the respective agreement shall apply. NXP Semiconductors hereby expressly objects to applying the customer's general terms and conditions with regard to the purchase of NXP Semiconductors products by customer.

No offer to sell or license — Nothing in this document may be interpreted or construed as an offer to sell products that is open for acceptance or the grant, conveyance or implication of any license under any copyrights, patents or other industrial or intellectual property rights.

Suitability for use in automotive applications — This NXP Semiconductors product has been qualified for use in automotive applications. Unless otherwise agreed in writing, the product is not designed, authorized or warranted to be suitable for use in life support, life-critical or safety-critical systems or equipment, nor in applications where failure or malfunction of an NXP Semiconductors product can reasonably be expected

to result in personal injury, death or severe property or environmental damage. NXP Semiconductors and its suppliers accept no liability for inclusion and/or use of NXP Semiconductors products in such equipment or applications and therefore such inclusion and/or use is at the customer's own risk.

Export control — This document as well as the item(s) described herein may be subject to export control regulations. Export might require a prior authorization from competent authorities.

Translations — A non-English (translated) version of a document is for reference only. The English version shall prevail in case of any discrepancy between the translated and English versions.

Security — Customer understands that all NXP products may be subject to unidentified or documented vulnerabilities. Customer is responsible for the design and operation of its applications and products throughout their lifecycles to reduce the effect of these vulnerabilities on customer's applications and products. Customer's responsibility also extends to other open and/or proprietary technologies supported by NXP products for use

in customer's applications. NXP accepts no liability for any vulnerability. Customer should regularly check security updates from NXP and follow up appropriately. Customer shall select products with security features that best meet rules, regulations, and standards of the intended application and make the ultimate design decisions regarding its products and is solely responsible for compliance with all legal, regulatory, and security related requirements concerning its products, regardless of any information or support that may be provided by NXP. NXP has a Product Security Incident Response Team (PSIRT) (reachable at PSIRT@nxp.com) that manages the investigation, reporting, and solution release to security vulnerabilities of NXP products.

14.4 Trademarks

Notice: All referenced brands, product names, service names and trademarks are the property of their respective owners.

SafeAssure — is a trademark of NXP B.V.

Tables

Tab. 1.	Orderable parts	2	Tab. 16.	Configuration and control	19
Tab. 2.	Pin description	4	Tab. 17.	Configuration and control bits description	19
Tab. 3.	Maximum ratings	8	Tab. 18.	VPWR_UV electrical characterization	21
Tab. 4.	Thermal ratings	9	Tab. 19.	VPWR_OV electrical characterization	21
Tab. 5.	Nominal operation	10	Tab. 20.	OT electrical characterization	22
Tab. 6.	Supply current consumption	10	Tab. 21.	Truth table	23
Tab. 7.	Digital I/Os characteristics	11	Tab. 22.	Error handling	24
Tab. 8.	Electrical characteristics	15	Tab. 23.	Frequency electrical characteristics	25
Tab. 9.	Electrical characteristics	17	Tab. 24.	Charge pump electrical characteristics	26
Tab. 10.	Timing parameters for clearing fault status	17	Tab. 25.	VDDQ electrical characterizations	26
Tab. 11.	SPI register selection	18	Tab. 26.	H-Bridge mode fault priority	27
Tab. 12.	Device identification (Reserved)	18	Tab. 27.	Half-bridge mode fault priority	28
Tab. 13.	Status	18	Tab. 28.	Fault priority description	28
Tab. 14.	Status bits description	18	Tab. 29.	H-bridge electrical characterization	32
Tab. 15.	Fault status mask	19	Tab. 30.	Package outline	37

Figures

Fig. 1.	Simplified application diagram	1	Fig. 18.	Disable delay timing	34
Fig. 2.	Internal block diagram	3	Fig. 19.	Output delay timing	34
Fig. 3.	Pin configuration for 32-pin SOICW	4	Fig. 20.	Slew rate	34
Fig. 4.	Pin configuration for 32-pin PQFN	4	Fig. 21.	Simplified minimum application schematic (Reverse battery protection using a diode and operation without SPI)	35
Fig. 5.	Functional block diagram	12	Fig. 22.	Simplified typical application schematic (Reverse battery protection with an external inverted N-channel MOSFET and operation with SPI)	36
Fig. 6.	Operating mode state diagram	14	Fig. 23.	Output avalanche protection	37
Fig. 7.	Regulators power-up and power-down sequences	15	Fig. 24.	Package outline for 32-pin SOICW-EP	38
Fig. 8.	SPI dynamic diagram	16	Fig. 25.	Package outline detail for 32-pin SOICW-EP	39
Fig. 9.	Output operating configurations	23	Fig. 26.	Package outline notes for 32-pin SOICW-EP	40
Fig. 10.	H-bridge operation with ENBL = 1 and DIS = 0	24	Fig. 27.	Package outline for 32-pin PQFN	41
Fig. 11.	Half-bridge operation with ENBL = 1 and DIS = 0	24	Fig. 28.	Package outline detail for 32-pin PQFN	42
Fig. 12.	Digital output buffer supply	26	Fig. 29.	Package outline notes for 32-pin PQFN	43
Fig. 13.	Simplified current regulated loop for ILIM	29			
Fig. 14.	ILIM timing and thermal response	30			
Fig. 15.	Open load detection circuit	31			
Fig. 16.	Open load detection circuit for active mode	31			
Fig. 17.	Open load circuit operation	32			

Contents

1	General description	1	9.7.2	VPWR overvoltage detection	21
2	Simplified application diagram	1	9.7.2.1	Electrical characteristics	21
3	Features and benefits	1	9.7.3	Die temperature	21
4	Applications	2	9.7.3.1	Description	21
5	Ordering information	2	9.7.3.2	Electrical characteristics	22
6	Internal block diagram	3	9.7.4	Truth table	22
7	Pinning information	4	9.8	Error handling	24
7.1	Pinning	4	10	Functional block description	25
7.2	Pin description	4	10.1	Oscillator	25
7.3	Functional pin description	5	10.1.1	Frequency modulation	25
7.3.1	Logic bias input (VDDQ)	5	10.2	Charge pump	25
7.3.2	Supply voltage (VPWR)	5	10.2.1	Description	25
7.3.3	Outputs (OUT1 and OUT2)	6	10.3	VDDQ digital output supply voltage	26
7.3.4	Inputs (IN1 and IN2)	6	10.3.1	Description	26
7.3.5	Enable inputs (ENBL)	6	10.4	H-bridge and Half-bridge operation	27
7.3.6	Disable inputs (DIS)	6	10.4.1	Description	27
7.3.7	Current recopy (CFB)	6	10.4.1.1	H-bridge and Half-bridge fault priority	27
7.3.8	Charge pump capacitor (CCP)	6	10.4.1.2	Current recopy	28
7.3.9	Serial peripheral interface (SPI)	7	10.4.1.3	Slew rate selection	28
7.3.9.1	Serial clock (SCLK)	7	10.4.1.4	Active current limit regulation	28
7.3.9.2	Serial data output (MISO)	7	10.4.1.5	Open load detection in standby mode	30
7.3.9.3	Serial data input (MOSI)	7	10.4.1.6	Open load detection in active mode	31
7.3.9.4	Chip select (CS_B)	7	10.4.1.7	Short-circuit detection	32
7.3.10	Status fault (FS_B)	7	10.4.2	Electrical characteristics	32
8	General product characteristics	8	11	Applications	34
8.1	Maximum ratings	8	11.1	Introduction	34
8.2	Thermal characteristics	9	11.2	Application diagram	35
8.3	Operating conditions	10	11.3	Output avalanche protection	36
8.3.1	Reverse battery	10	12	Packaging	37
8.3.2	Digital I/Os characteristics	11	12.1	Package mechanical dimensions	37
9	General IC functional description and application information	11	13	Revision history	44
9.1	Introduction	11	14	Legal information	45
9.2	Features	11			
9.3	Functional block diagram	12			
9.4	Functional description	12			
9.4.1	H-bridge output drivers (OUT1 and OUT2)	12			
9.4.2	Analog control, protection, and diagnostics	13			
9.4.3	MCU interface and output control	13			
9.5	Modes of operation	13			
9.5.1	Description	13			
9.5.2	Electrical characteristics	15			
9.6	16-bit SPI interface	16			
9.6.1	Description	16			
9.6.2	Electrical characteristics	17			
9.6.3	SPI fault reporting	17			
9.6.3.1	Clearing the fault status	17			
9.6.3.2	SPI framing error detection	17			
9.6.4	SPI mapping	18			
9.7	Protection and supervision	20			
9.7.1	VPWR undervoltage detection	20			
9.7.1.1	Description	20			
9.7.1.2	Electrical characteristics	21			

Please be aware that important notices concerning this document and the product(s) described herein, have been included in section 'Legal information'.