

LEAD FREE CONVERSION EC NO: UCP2013-4288 DRW:RWHIPPLE 2013/04/09 CHK:MMOLFE 2013/04/09 APPR:SMILLER 2013/08/26	QUALITY SYMBOLS 	GENERAL TOLERANCES (UNLESS SPECIFIED)		DIMENSION STYLE MM ONLY	SCALE 3:1	DESIGN UNITS METRIC	THIRD ANGLE PROJECTION	
		4 PLACES ± --- ± ---	DRAWN BY BPISZCZOR	DATE 2007/02/28	TITLE I-TRAC 15 ROW BP GUIDE RIGHT ASSEMBLY SALES DRAWING			
		3 PLACES ± --- ± ---	CHECKED BY JLAURX	DATE 2007/02/28	molex			
		2 PLACES ± 0.13 ± ---	APPROVED BY CBIXLER	DATE 2007/02/28	MATERIAL NO. SEE CHART	DOCUMENT NO. SD-76035-004	SHEET NO. 1 OF 4	
1 PLACE ± 0.25 ± ---	ANGULAR ±1/2°		DRAFT WHERE APPLICABLE MUST REMAIN WITHIN DIMENSIONS					
0 PLACE ± ±	THIS DRAWING CONTAINS INFORMATION THAT IS PROPRIETARY TO MOLEX INCORPORATED AND SHOULD NOT BE USED WITHOUT WRITTEN PERMISSION							

76035-****

MODULE TYPE -- TAIL PLATING TYPE
 GUIDE RIGHT -- MATTE TIN (FORMERLY TIN/LEAD) = 4
 GUIDE RIGHT -- MATTE TIN = 5
 GUIDE RIGHT W/END WALL -- MATTE TIN (FORMERLY TIN/LEAD) = 8
 GUIDE RIGHT W/END WALL -- MATTE TIN = 9

OF COLUMNS
 8 = 8 COL
 9 = 9 COL
 1 = 10 COL

KEY ORIENTATION
 0 = NO KEY
 1 = A
 2 = B
 3 = C
 4 = D
 5 = E
 6 = F
 7 = G
 8 = H

PIN LENGTH (P)
 2 = 3.90 - 30 GOLD
 3 = 4.70 - 30 GOLD
 4 = 5.70 - 30 GOLD
 5 = 4.70 & 5.70 - 30 GOLD STAGGERED
 6 = 3.90 - 10 GOLD
 7 = 4.70 - 10 GOLD
 8 = 5.70 - 10 GOLD
 9 = 4.70 & 5.70 - 10 GOLD STAGGERED

MATERIAL NUMBER	# OF COLUMNS	DIM "A"	DIM "B"
76035-48**	8	35.9	25.90
76035-49**	9	39.6	29.60
76035-41**	10	43.3	33.30
76035-51**	8	35.9	25.90
76035-59**	9	39.6	29.60
76035-51**	10	43.3	33.30

GUIDE RIGHT STYLE

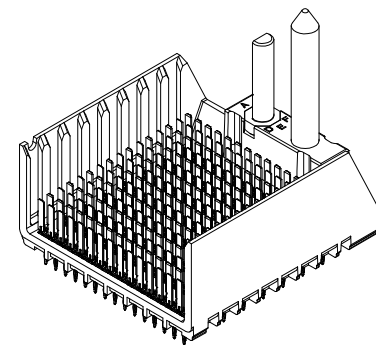

MATERIAL NUMBER	# OF COLUMNS	DIM "A"	DIM "B"
76035-88**	8	37.2	25.90
76035-89**	9	40.9	29.60
76035-81**	10	44.6	33.30
76035-98**	8	37.2	25.90
76035-99**	9	40.9	29.60
76035-91**	10	44.6	33.30

GUIDE RIGHT W/END WALL STYLE

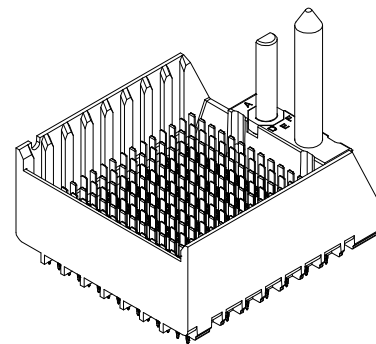

SEE SHEET 1 EC NO: UCP2013-4288 DRW: RMH/PPLE 2013/04/09 CHK: DMOLFE 2013/04/09 APPR: SMILLER 2013/08/26	QUALITY SYMBOLS ▽=0 ▽=0 ▽=0	GENERAL TOLERANCES (UNLESS SPECIFIED)		DIMENSION STYLE MM ONLY		SCALE 4:1	DESIGN UNITS METRIC	THIRD ANGLE PROJECTION		
		4 PLACES ± --- ± ---	3 PLACES ± --- ± ---	2 PLACES ± 0.13 ± ---	1 PLACE ± 0.25 ± ---	0 PLACE ± ±	DRAWN BY DATE BPISZCZOR 2007/02/28	I-TRAC 15 ROW BP GUIDE RIGHT ASSEMBLY SALES DRAWING		
		ANGULAR ±1/2°					CHECKED BY DATE JLAURX 2007/02/28	molex		
		DRAFT WHERE APPLICABLE MUST REMAIN WITHIN DIMENSIONS					APPROVED BY DATE CBIXLER 2007/02/28	DOCUMENT NO. SD-76035-004	SHEET NO. 2 OF 4	
THIS DRAWING CONTAINS INFORMATION THAT IS PROPRIETARY TO MOLEX INCORPORATED AND SHOULD NOT BE USED WITHOUT WRITTEN PERMISSION										

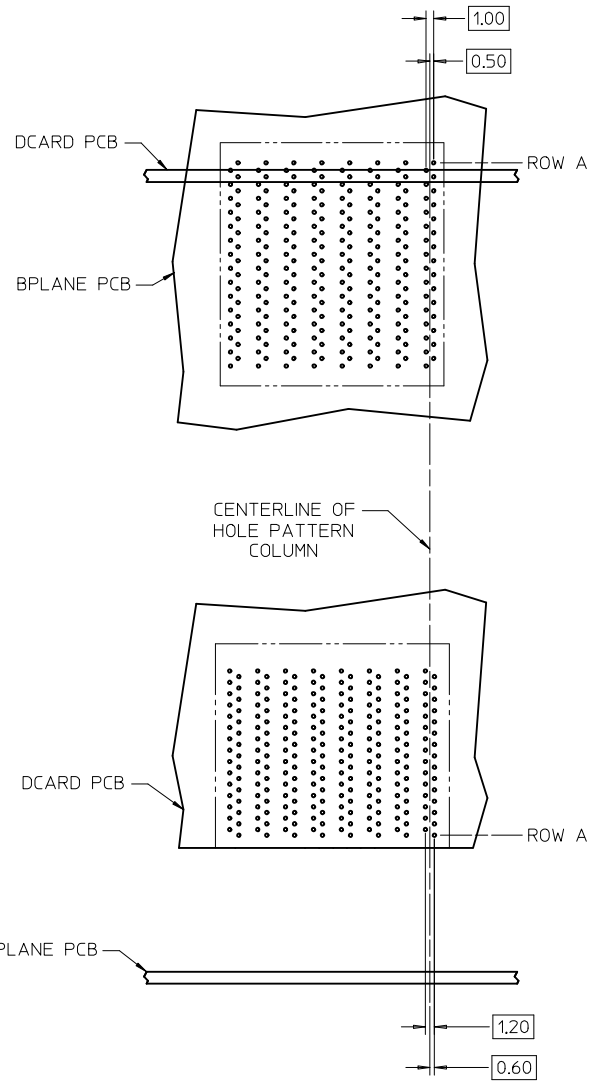

15 ROW I-TRAC BOARD RELATIONSHIPS

SCALE 2:1

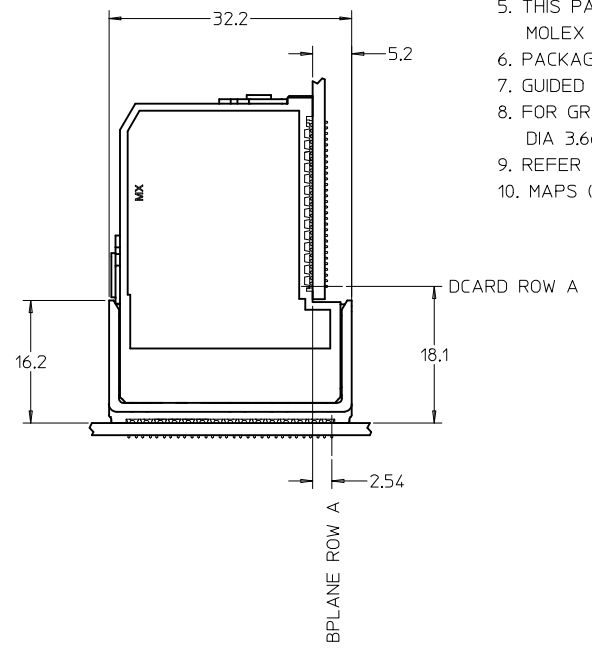

NOTES:

1. MATERIALS: HOUSING - LIQUID CRYSTAL POLYMER (LCP)
GLASS-FILLED, UL94V-0
TERMINALS - HIGH PERFORMANCE COPPER ALLOY
2. FINISH: 10 MICROINCH MIN.(MAPS) GOLD OR 30 MICROINCH MIN. GOLD
IN CONTACT AREA. SELECTIVE MATTE TIN ON PCB TAILS, NICKEL OVERALL.
3. REFER TO MOLEX PRODUCT SPECIFICATION PS-75710-999
FOR PERFORMANCE SPECIFICATIONS.
4. FOR MIXED CONTACT MATING LENGTHS, CONSULT MOLEX
FOR AVAILABILITY.
5. THIS PART CONFORMS TO CLASS B REQUIREMENTS OF
MOLEX COSMETIC SPEC PS-45499-002.
6. PACKAGE PER: PK-70873-586.
7. GUIDED PARTS TO BE SHIPPED WITH 2-56 UNC B SCREW P/N 73774-1000.
8. FOR GROUNDED GUIDE PINS USE DIA 3.56+/-0.08 (PTH),
DIA 3.66 (DRILL), AND DIA 6.5 (PAD).
9. REFER TO PCB ROUTING GUIDE FOR ANTIPAD AND ROUTING RECOMMENDATIONS.
10. MAPS (MOLEX ADVANCED PLATING SYSTEM).

SEE SHEET 1 EC NO: UCP2013-4288 DRW:RWHIPPLE 2013/04/09 CHKD:HWOLFE 2013/04/09 APPR:SMILLER 2013/08/26	QUALITY SYMBOLS ▽=0 ▽=0 ▽=0	GENERAL TOLERANCES (UNLESS SPECIFIED) <table border="1"> <tr> <th></th> <th>mm</th> <th>INCH</th> </tr> <tr> <td>4 PLACES</td> <td>± ---</td> <td>± ---</td> </tr> <tr> <td>3 PLACES</td> <td>± ---</td> <td>± ---</td> </tr> <tr> <td>2 PLACES</td> <td>± 0.13</td> <td>± ---</td> </tr> <tr> <td>1 PLACE</td> <td>± 0.25</td> <td>± ---</td> </tr> <tr> <td>0 PLACE</td> <td>±</td> <td>±</td> </tr> </table>		mm	INCH	4 PLACES	± ---	± ---	3 PLACES	± ---	± ---	2 PLACES	± 0.13	± ---	1 PLACE	± 0.25	± ---	0 PLACE	±	±	DIMENSION STYLE MM ONLY DRAWN BY DATE BPISZCZOR 2007/02/28 CHECKED BY DATE JLAURX 2007/02/28 APPROVED BY DATE CBIXLER 2007/02/28	SCALE 4:1 DESIGN UNITS METRIC THIRD ANGLE PROJECTION	TITLE I-TRAC 15 ROW BP GUIDE RIGHT ASSEMBLY SALES DRAWING molex DOCUMENT NO. SD-76035-004 SHEET NO. 3 OF 4
		mm	INCH																				
	4 PLACES	± ---	± ---																				
	3 PLACES	± ---	± ---																				
2 PLACES	± 0.13	± ---																					
1 PLACE	± 0.25	± ---																					
0 PLACE	±	±																					
REV DESCRIPTION	ANGULAR ±1/2° DRAFT WHERE APPLICABLE MUST REMAIN WITHIN DIMENSIONS	MATERIAL NO. SEE CHART SIZE C	THIS DRAWING CONTAINS INFORMATION THAT IS PROPRIETARY TO MOLEX INCORPORATED AND SHOULD NOT BE USED WITHOUT WRITTEN PERMISSION																				

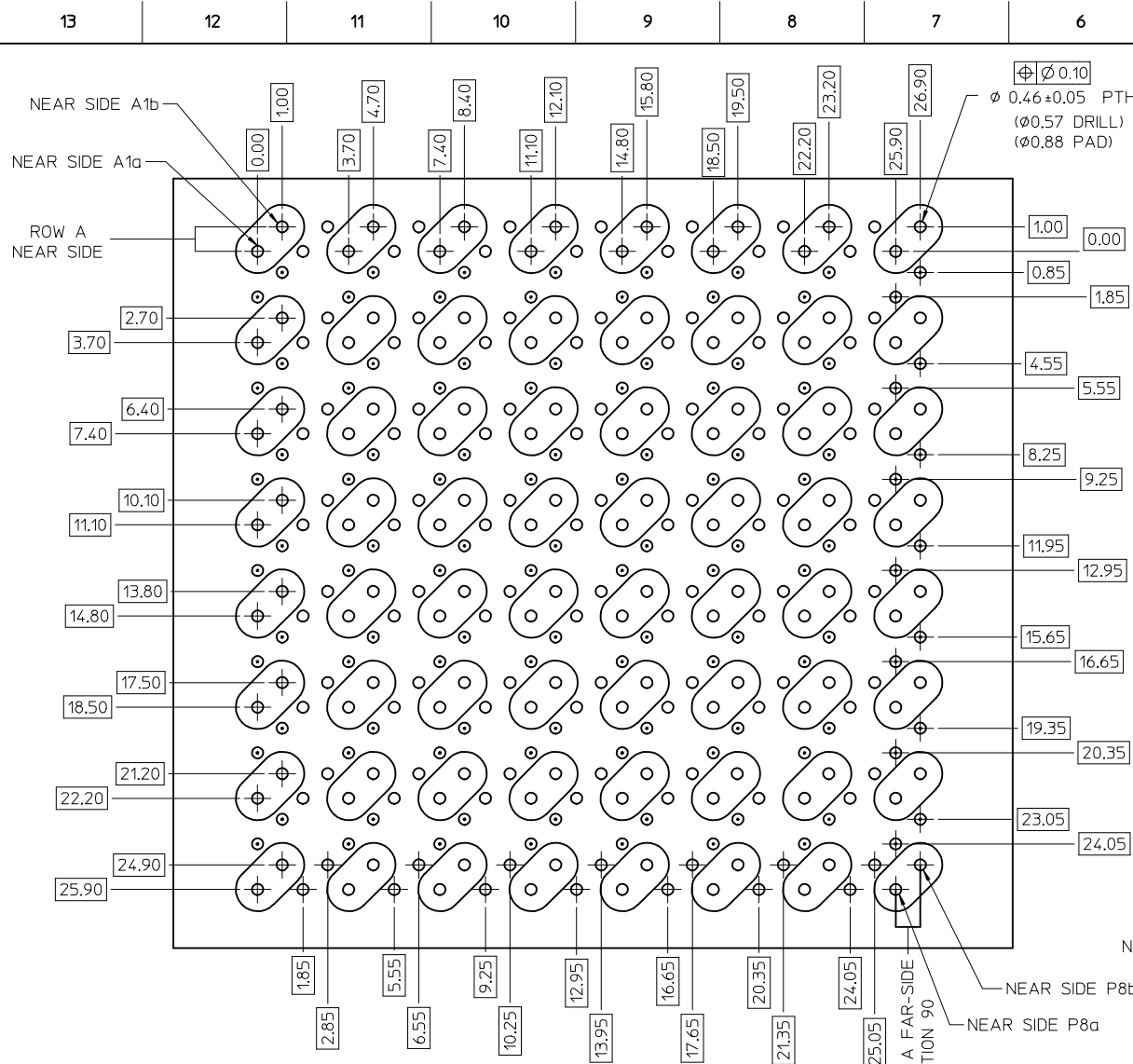

ORTHO PIN MAPPING

OPTION 90 (NEAR SIDE - FAR SIDE)

A1b-P8b	A2b-N8b	A3b-L8b	A4b-J8b	A5b-G8b	A6b-E8b	A7b-C8b	A8b-A8b
A1a-P8a	A2a-N8a	A3a-L8a	A4a-J8a	A5a-G8a	A6a-E8a	A7a-C8a	A8a-A8a
C1b-P7b	C2b-N7b	C3b-L7b	C4b-J7b	C5b-G7b	C6b-E7b	C7b-C7b	C8b-A7b
C1a-P7a	C2a-N7a	C3a-L7a	C4a-J7a	C5a-G7a	C6a-E7a	C7a-C7a	C8a-A7a
E1b-P6b	E2b-N6b	E3b-L6b	E4b-J6b	E5b-G6b	E6b-E6b	E7b-C6b	E8b-A6b
E1a-P6a	E2a-N6a	E3a-L6a	E4a-J6a	E5a-G6a	E6a-E6a	E7a-C6a	E8a-A6a
G1b-P5b	G2b-N5b	G3b-L5b	G4b-J5b	G5b-G5b	G6b-E5b	G7b-C5b	G8b-A5b
G1a-P5a	G2a-N5a	G3a-L5a	G4a-J5a	G5a-G5a	G6a-E5a	G7a-C5a	G8a-A5a
I1b-P4b	I2b-N4b	I3b-L4b	I4b-J4b	I5b-G4b	I6b-E4b	I7b-C4b	I8b-A4b
I1a-P4a	I2a-N4a	I3a-L4a	I4a-J4a	I5a-G4a	I6a-E4a	I7a-C4a	I8a-A4a
L1b-P3b	L2b-N3b	L3b-L3b	L4b-J3b	L5b-G3b	L6b-E3b	L7b-C3b	L8b-A3b
L1a-P3a	L2a-N3a	L3a-L3a	L4a-J3a	L5a-G3a	L6a-E3a	L7a-C3a	L8a-A3a
N1b-P2b	N2b-N2b	N3b-L2b	N4b-J2b	N5b-G2b	N6b-E2b	N7b-C2b	N8b-A2b
N1a-P2a	N2a-N2a	N3a-L2a	N4a-J2a	N5a-G2a	N6a-E2a	N7a-C2a	N8a-A2a
P1b-P1b	P2b-N1b	P3b-L1b	P4b-J1b	P5b-G1b	P6b-E1b	P7b-C1b	P8b-A1b
P1a-P1a	P2a-N1a	P3a-L1a	P4a-J1a	P5a-G1a	P6a-E1a	P7a-C1a	P8a-A1a

ORTHO PIN MAPPING

OPTION 270 (NEAR SIDE - FAR SIDE)

A1b-A1a	A2b-C1a	A3b-E1a	A4b-G1a	A5b-J1a	A6b-L1a	A7b-N1a	A8b-P1a
A1a-A1b	A2a-C1b	A3a-E1b	A4a-G1b	A5a-J1b	A6a-L1b	A7a-N1b	A8a-P1b
C1b-A2a	C2b-C2a	C3b-E2a	C4b-G2a	C5b-J2a	C6b-L2a	C7b-N2a	C8b-P2a
C1a-A2b	C2a-C2b	C3a-E2b	C4a-G2b	C5a-J2b	C6a-L2b	C7a-N2b	C8a-P2b
E1b-A3a	E2b-C3a	E3b-E3a	E4b-G3a	E5b-J3a	E6b-L3a	E7b-N3a	E8b-P3a
E1a-A3b	E2a-C3b	E3a-E3b	E4a-G3b	E5a-J3b	E6a-L3b	E7a-N3b	E8a-P3b
G1b-A4a	G2b-C4a	G3b-E4a	G4b-G4a	G5b-J4a	G6b-L4a	G7b-N4a	G8b-P4a
G1a-A4b	G2a-C4b	G3a-E4b	G4a-G4b	G5a-J4b	G6a-L4b	G7a-N4b	G8a-P4b
J1b-A5a	J2b-C5a	J3b-E5a	J4b-G5a	J5b-J5a	J6b-L5a	J7b-N5a	J8b-P5a
J1a-A5b	J2a-C5b	J3a-E5b	J4a-G5b	J5a-J5b	J6a-L5b	J7a-N5b	J8a-P5b
L1b-A6a	L2b-C6a	L3b-E6a	L4b-G6a	L5b-J6a	L6b-L6a	L7b-N6a	L8b-P6a
L1a-A6b	L2a-C6b	L3a-E6b	L4a-G6b	L5a-J6b	L6a-L6b	L7a-N6b	L8a-P6b
N1b-A7a	N2b-C7a	N3b-E7a	N4b-G7a	N5b-J7a	N6b-L7a	N7b-N7a	N8b-P7a
N1a-A7b	N2a-C7b	N3a-E7b	N4a-G7b	N5a-J7b	N6a-L7b	N7a-N7b	N8a-P7b
P1b-A8a	P2b-C8a	P3b-E8a	P4b-G8a	P5b-J8a	P6b-L8a	P7b-N8a	P8b-P8a
P1a-A8b	P2a-C8b	P3a-E8b	P4a-G8b	P5a-J8b	P6a-L8b	P7a-N8b	P8a-P8b

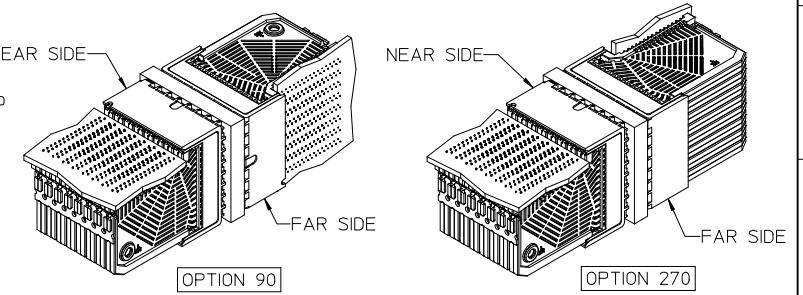

Orthogonal PCB Layout

- NOTES:
- SIGNAL PAIRS (SHARED VIAS)
 - NEAR SIDE GROUNDS
 - FAR SIDE GROUNDS

SEE SHEET 1 EC NO: UCP2013-4288 DRW: RWHIPPLE 2013/04/09 CHKD: MWOLFE 2013/04/09 APPR: SMILLER 2013/08/26	QUALITY SYMBOLS 	GENERAL TOLERANCES (UNLESS SPECIFIED) <table border="1"> <tr><th>mm</th><th>INCH</th></tr> <tr><td>4 PLACES ± ---</td><td>± ---</td></tr> <tr><td>3 PLACES ± ---</td><td>± ---</td></tr> <tr><td>2 PLACES ± 0.13</td><td>± ---</td></tr> <tr><td>1 PLACE ± 0.25</td><td>± ---</td></tr> <tr><td>0 PLACE ±</td><td>±</td></tr> </table>	mm	INCH	4 PLACES ± ---	± ---	3 PLACES ± ---	± ---	2 PLACES ± 0.13	± ---	1 PLACE ± 0.25	± ---	0 PLACE ±	±	DIMENSION STYLE MM ONLY	SCALE 4:1	DESIGN UNITS METRIC	THIRD ANGLE PROJECTION
	mm	INCH																
	4 PLACES ± ---	± ---																
	3 PLACES ± ---	± ---																
2 PLACES ± 0.13	± ---																	
1 PLACE ± 0.25	± ---																	
0 PLACE ±	±																	
MATERIAL NO. SEE CHART	DOCUMENT NO. SD-76035-004	SHEET NO. 4 OF 4																
DRAFT WHERE APPLICABLE MUST REMAIN WITHIN DIMENSIONS			molex															
THIS DRAWING CONTAINS INFORMATION THAT IS PROPRIETARY TO MOLEX. INCORPORATED AND SHOULD NOT BE USED WITHOUT WRITTEN PERMISSION																		