

▶ MJ2 SERIES MICRO SWITCHES

● MJ2-1308R-PT

◆ FEATURES/功能

- Regular or sealed operating heads. / 一般或密封式頭部
- Momentary contacts. / 接點敏捷
- Completely sealed constructure. / 輔助密封式結構
- Wide choice of heads and actuators. / 多種不同的頭及連桿
- Plastic(Standard) or phenolic housing. / 塑膠(標準型)或電木外殼
- Regular or light operating force. / 一般型或輕動作力型
- Temperature range +5°F to +175°F (-15°C to +80°C). / 適用溫度
- Soldering Terminal or Fast Terminal / 焊接端子或快速接腳端子



● MJ2-1308



◆ CIRCUITRY/電氣回路

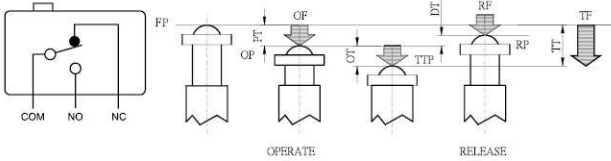

OF : Operating Force TTP : Total Travel Position
 RF : Releasing Force PT : Pretravel
 TF : Total Force OT : Overtravel
 FP : Free Position DT : Travel Differential
 OP : Operating Position TT : Total Travel
 RP : Releasing Position

◆ CHARACTERISTICS/特性

Operating speed	0.01mm to 1m/sec
Operating frequency	Mechanically: 240 operations/min. Electrically: 20 operations/min.
Contact resistance	15m Ω max. (initial)
Insulation resistance	100M Ω min. (at 500 VDC)
Dielectric strength	1,000 VAC, 50/60 Hz for 1 minute between non-continuous terminals 2,000 VAC, 50/60 Hz for 1 minute between current-carry part and ground
Vibration	Malfunction durability: 10 to 55Hz 1.5mm double amplitude
Shock	Mechanical durability: Approx. 1,000m/sec ² (approx. 100G's) Malfunction durability: Approx. 300 m/sec ² (approx. 30G's)
Ambient operating temperature	General purpose type: -25° to +80°C Sealed type: -15 to 80°C
Humidity	General purpose type: 85% RH max Sealed type: 95% RH
Service life	Mechanically: 20,000,000 operations min Electrically:(1.7A,110VAC)MAX 500,000 operations min.



◆ RATING/額定

15A	125 or 250V AC
1/8 HP	125 V AC
1/4 HP	250 V AC
0.5 A	125 V DC
0.25 A	250 V DC

◆ REMARK

● OIL TIGHT SERIES

- MJ2-1315 MJ2-1317
- MJ2-1513 MJ2-1514 MJ2-1515
- MJ2-1515-P
- MJ2-1711 MJ2-1712 MJ2-1713
- MJ2-1714 MJ2-1721

● SENSITIVITY ADJUSTABLE SERIES

- MJ2-1513 MJ2-1514 MJ2-1543 MJ2-1544
- MJ2-1701 MJ2-1702 MJ2-1703 MJ2-1704
- MJ2-1711 MJ2-1712 MJ2-1713 MJ2-1714

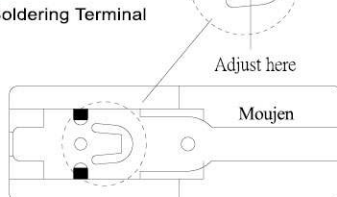

DIMENSIONS (mm)

OPERATING CHARACTERISTICS

MJ2-1300

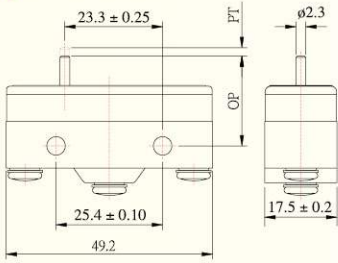

MJ2-1300	
OF MAX	250-450g
RF MIN	114g
PT MAX	0.5mm
OT MIN	0.13mm
DT MAX	0.05mm
FP MAX	
OP	15.9±0.4mm

DIMENSIONS (mm)

OPERATING CHARACTERISTICS

MJ2-1315

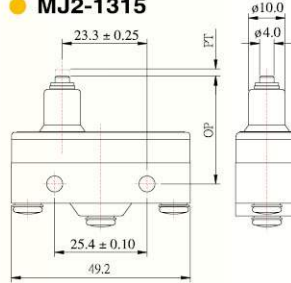

MJ2-1315	
OF MAX	540g
RF MIN	114g
PT MAX	1.9mm
OT MIN	1.6mm
DT MAX	0.06mm
FP MAX	
OP	28.2±0.5mm

MJ2-1305

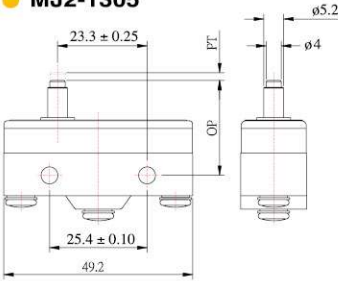

MJ2-1305	
OF MAX	250-450g
RF MIN	114g
PT MAX	0.5mm
OT MIN	1.6mm
DT MAX	0.05mm
FP MAX	
OP	28.2±0.5mm

MJ2-1317

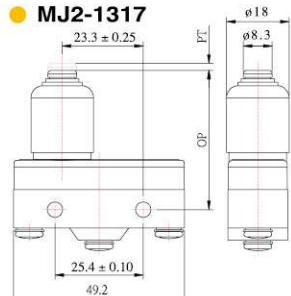

MJ2-1317	
OF MAX	540g
RF MIN	114g
PT MAX	2.4mm
OT MIN	3.5mm
DT MAX	0.06mm
FP MAX	
OP	38.1±1.2mm

MJ2-1306

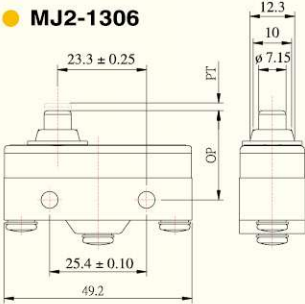

MJ2-1306	
OF MAX	250-450g
RF MIN	114g
PT MAX	0.5mm
OT MIN	1.6mm
DT MAX	0.05mm
FP MAX	
OP	21.5±0.5mm

MJ2-1513

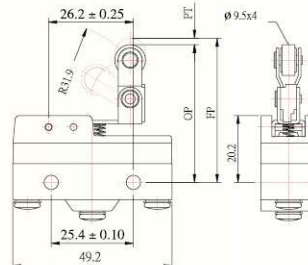

MJ2-1513	
OF MAX	180g
RF MIN	50g
PT MAX	2.7mm
OT MIN	2.4mm
DT MAX	0.8mm
FP MAX	43.6mm
OP	41.3±0.8mm

MJ2-1307

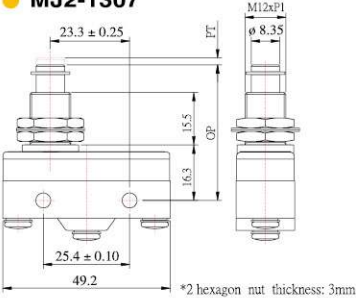

MJ2-1307	
OF MAX	250-450g
RF MIN	114g
PT MAX	0.5mm
OT MIN	5.5mm
DT MAX	0.05mm
FP MAX	
OP	38.1±0.8mm

*2 hexagon nut thickness: 3mm

MJ2-1514

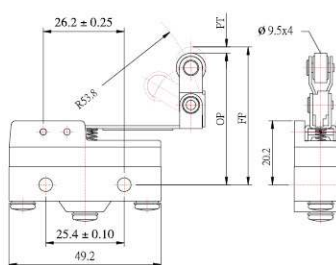

MJ2-1514	
OF MAX	150g
RF MIN	25g
PT MAX	6.4mm
OT MIN	4.0mm
DT MAX	1.6mm
FP MAX	47.2mm
OP	41.3±0.8mm

MJ2-1308

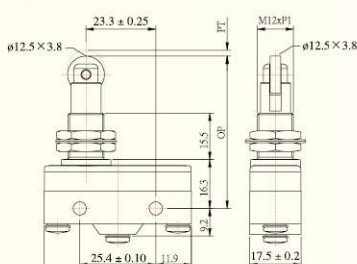

MJ2-1308	
OF MAX	250-450g
RF MIN	114g
PT MAX	0.5mm
OT MIN	3.58mm
DT MAX	0.05mm
FP MAX	
OP	49.7±1.2mm

*2 hexagon nut thickness: 3mm

MJ2-1515

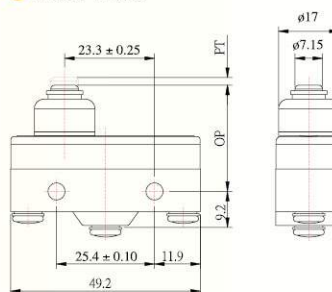

MJ2-1515	
OF MAX	540g
RF MIN	114g
PT MAX	2.3mm
OT MIN	1.6mm
DT MAX	0.06mm
FP MAX	
OP	28.2±0.5mm

▶ MJ2 SERIES MICRO SWITCHES

◆ ORDER GUIDE

● Plastic body & Nylon Plastic roller (Standard Type) 塑膠外殼 & 尼龍塑膠滾輪 (標準型) :

MJ2-1280	MJ2-1300	MJ2-1305	MJ2-1306	MJ2-1307	MJ2-1308-P	MJ2-1308R-P	MJ2-1543	MJ2-1544
MJ2-1578	MJ2-1701	MJ2-1702	MJ2-1703	MJ2-1704	MJ2-1315	MJ2-1317	MJ2-1513	MJ2-1514
MJ2-1515	MJ2-1711	MJ2-1712	MJ2-1713	MJ2-1714	MJ2-CB2			
MJ2-1721	MJ2-1741		MJ2-1730	MJ2-1732	MJ2-1737			

● Metal roller type(custom made) 金屬滾輪 (訂製品):

MJ2-1308	MJ2-1308R	MJ2-1703-F	MJ2-1704-F	MJ2-1737-F
----------	-----------	------------	------------	------------

● Type Number Ordering Code 型號命名定義表格: MJ2-

1	2	8	0					
①	②	③	④	⑤	⑥	⑦		



① Series basic definition code 系列基本定義的型號 MJ2 -

② Feature type number 成品編號的種類

1280~1744 set up ordinal number according to different driving devices.
Please refer to type picture and type number in the catalogue.
1280~1744 依照不同的傳動軸種類, 而設定的流水號
請參考目錄上敘述的圖片與成品編號

③ Body(case) material type 外殼材質的種類

Non-indicate 無表示: Plastic Body (standard) 塑膠外殼 (標準型)
P: Phenolic Body(custom made) 電木外殼 (訂製品)

④ OF(operating force) type OF操作力量的種類

Non-indicate 無表示: Normal force(standard) 一般正常的力量 (標準型)

⑤ Terminal type 端子的種類

Non-indicate 無表示: Only attached screw(standard)
只附加螺絲無組裝端子 (標準型)

S: Soldering Terminal Type (custom made) 有組裝焊接端子 (訂製品)

A: Fast Terminal Type(custom made) 有組裝快速接腳端子 (訂製品)

⑥ Roller or head material type 滾輪或頭部材質的種類

- P: Roller (Plastic: NYLON) 塑膠滾輪(尼龍)(黑色)

- PT: Head or Roller (custom made:TEFLON) 頭部或滾輪(訂製品:鐵氟龍)(白色)

- PM: Head (custom made: POM) 頭部(訂製品:POM)(白色)

⑦ High current type (custom made) 大電流型(訂製品)

- 20: 20A



DIMENSIONS (mm) OPERATING CHARACTERISTICS

● MJ2-1543

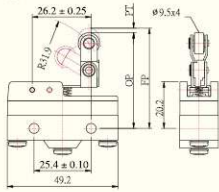

MJ2-1543	
OF MAX	170g
RF MIN	42g
PT MAX	2.7mm
OT MIN	2.4mm
DT MAX	0.51mm
FP MAX	43.6mm
OP	41.3±0.8mm

DIMENSIONS (mm) OPERATING CHARACTERISTICS

● MJ2-1711

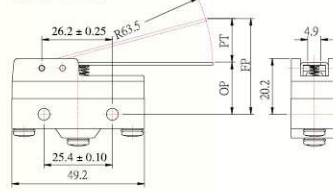

MJ2-1711	
OF MAX	100g
RF MIN	14g
PT MAX	10mm
OT MIN	5.6mm
DT MAX	2.0mm
FP MAX	28.2mm
OP	19±0.8mm

● MJ2-1544

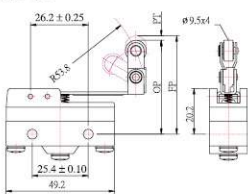

MJ2-1544	
OF MAX	110g
RF MIN	25g
PT MAX	6.4mm
OT MIN	4.0mm
DT MAX	1.6mm
FP MAX	47.2mm
OP	41.3±0.8mm

● MJ2-1712

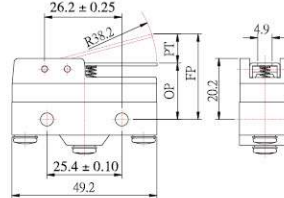

MJ2-1712	
OF MAX	150g
RF MIN	23g
PT MAX	7.9mm
OT MIN	3.0mm
DT MAX	1.5mm
FP MAX	26.2mm
OP	19±0.8mm

● MJ2-1578

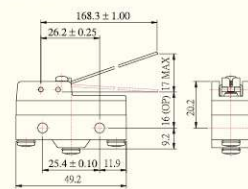

MJ2-1578	
OF MAX	10g
RF MIN	5g
PT MAX	10mm
OT MIN	6mm
DT MAX	3mm
FP MAX	
OP	20±1mm

● MJ2-1713

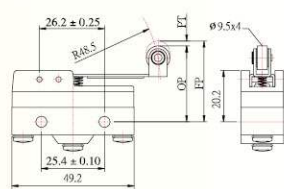

MJ2-1713	
OF MAX	130g
RF MIN	21g
PT MAX	7.1mm
OT MIN	4.0mm
DT MAX	1.6mm
FP MAX	36.5mm
OP	30.2±0.8mm

● MJ2-1701

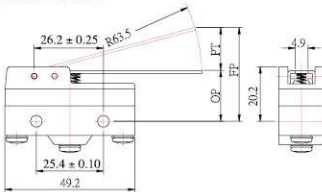

MJ2-1701	
OF MAX	70g
RF MIN	14g
PT MAX	10mm
OT MIN	5.6mm
DT MAX	1.27mm
FP MAX	28.2mm
OP	19±0.8mm

● MJ2-1714

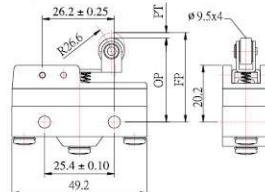

MJ2-1714	
OF MAX	200g
RF MIN	42g
PT MAX	3.5mm
OT MIN	2.4mm
DT MAX	0.5mm
FP MAX	34.5mm
OP	30.2±0.8mm

● MJ2-1702

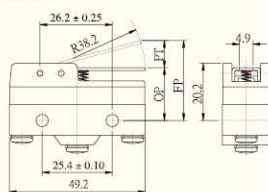

MJ2-1702	
OF MAX	120g
RF MIN	20g
PT MAX	7.9mm
OT MIN	3.0mm
DT MAX	1.0mm
FP MAX	26.2mm
OP	19±0.8mm

● MJ2-1730

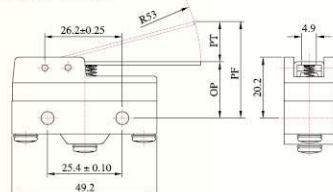

MJ2-1730	
OF MAX	90g
RF MIN	16g
PT MAX	9mm
OT MIN	4.8mm
DT MAX	1.15mm
FP MAX	27.2mm
OP	19±0.8mm

● MJ2-1703

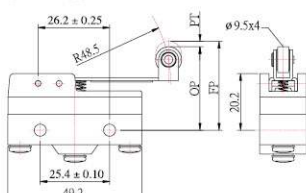

MJ2-1703	
OF MAX	100g
RF MIN	21g
PT MAX	7.1mm
OT MIN	4.0mm
DT MAX	1.6mm
FP MAX	36.5mm
OP	30.2±0.8mm

● MJ2-1732

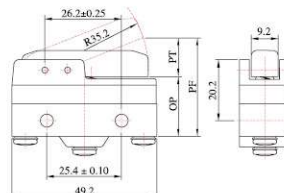

MJ2-1732	
OF MAX	180g
RF MIN	40g
PT MAX	6.0mm
OT MIN	1.4mm
DT MAX	1.5mm
FP MAX	30.1mm
OP	24.5±0.8mm

● MJ2-1704

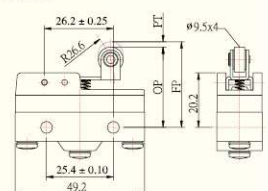

MJ2-1704	
OF MAX	160g
RF MIN	42g
PT MAX	3.5mm
OT MIN	2.4mm
DT MAX	0.5mm
FP MAX	34.5mm
OP	30.2±0.8mm

● MJ2-1737

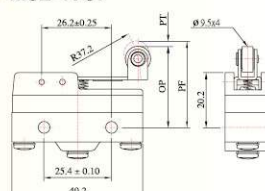

MJ2-1737	
OF MAX	125g
RF MIN	33g
PT MAX	5.7mm
OT MIN	3.4mm
DT MAX	1.1mm
FP MAX	35.8mm
OP	30.2±0.8mm