

Evaluation Board for Single, High Speed Operational Amplifiers (8-Lead, 3 mm × 3 mm LFCSP with Dedicated Feedback Pin)

FEATURES

- Enables quick breadboarding/prototyping**
- User-defined circuit configuration**
- Edge-mounted SMA connector provisions**
- Easy connection to test equipment and other circuits**

GENERAL DESCRIPTION

The EB-O8CP33-1Z is designed to aid in the evaluation of single, high speed operational amplifiers. The EB-O8CP33-1Z is a bare board (that is, there are no components soldered to the board) that enables users to quickly prototype a variety of operational amplifier circuits, which minimizes risk and reduces time to market. The EB-O8CP33-1Z evaluation board supports any of the Analog Devices, Inc., single, high speed operational amplifiers in 8-pin, 3 mm × 3 mm lead frame chip scale packages (LFCSP) with a dedicated feedback pin.

Figure 1 shows the component side and circuit side of the evaluation board. Figure 2 shows the evaluation board schematic.

The 4-layer evaluation board accepts edge-mounted SMA connectors on both inputs and outputs, which allows efficient and quick connection to test equipment or other circuitry.

The board ground plane, component placement, and power supply bypassing have been optimized for maximum circuit flexibility and performance. The evaluation board uses a variety of SMT component case sizes: 0402, 0508, 0603, and 7343.

Figure 3 and Figure 5 show the evaluation board assembly drawings. The metal layout pattern for connecting the board to the op amp and to the supporting circuitry is shown in Figure 4 and Figure 6.

DIGITAL PICTURE OF EVALUATION BOARD

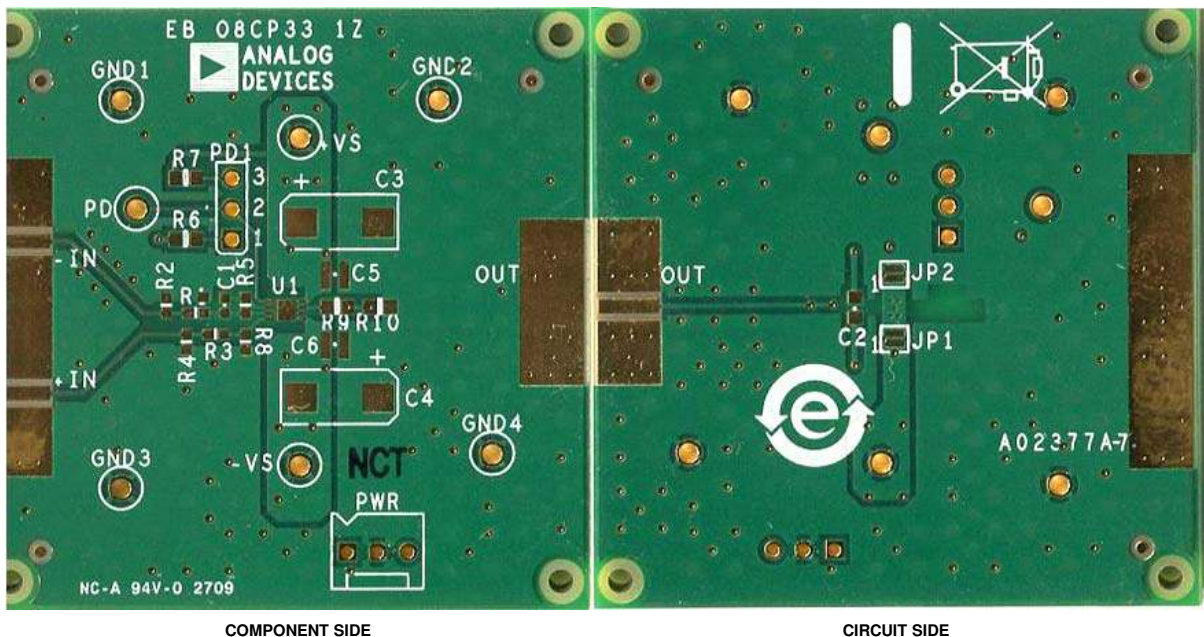

Figure 1. EB-O8CP33-1Z Component and Circuit Side of PCB

TABLE OF CONTENTS

Features	1	Evaluation Board Schematic	3
General Description	1	Assembly Drawing and Board Layout	4
Digital Picture of the Evaluation Board.....	1	ESD Caution.....	4
Revision History	2		

REVISION HISTORY

1/10—Revision 0: Initial Version

EVALUATION BOARD SCHEMATIC

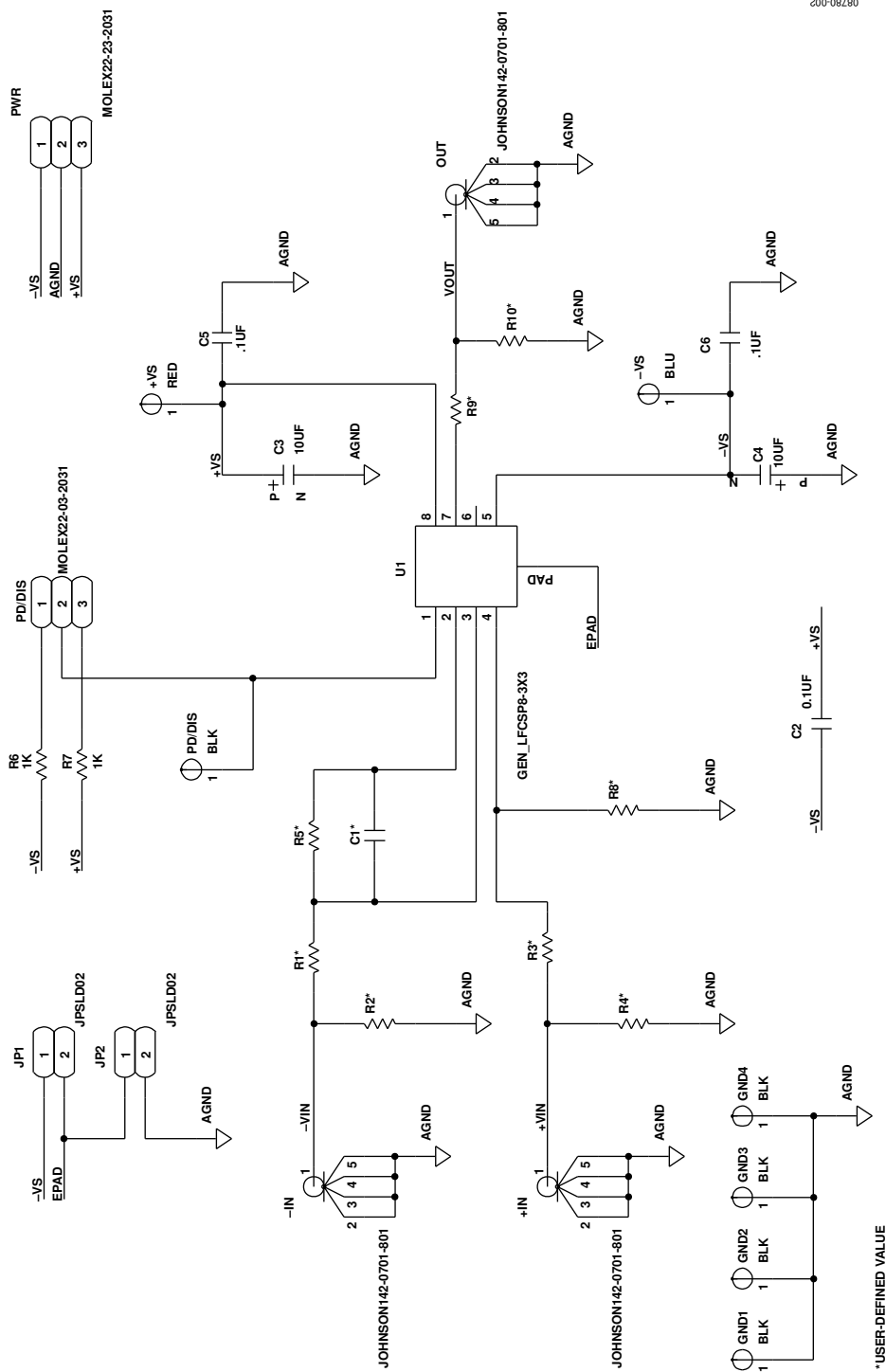

08780-002

Figure 2. Universal Evaluation Board Schematic

*USER-DEFINED VALUE

ASSEMBLY DRAWING AND BOARD LAYOUT

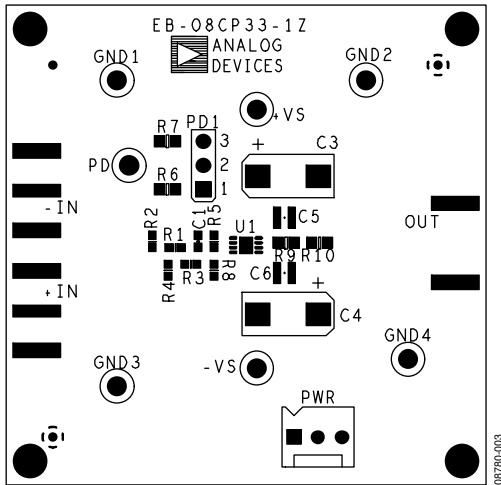

Figure 3. Board Assembly Drawing, Component Side

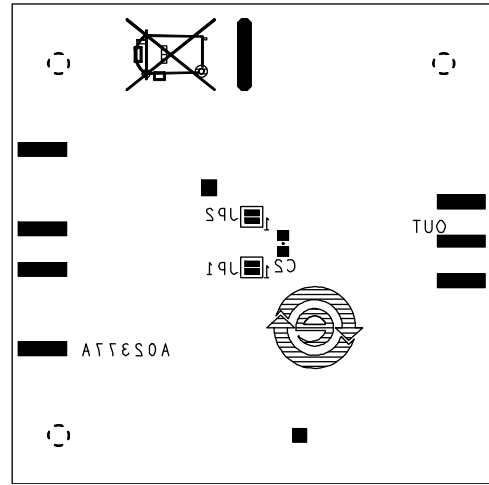

Figure 5. Board Assembly Drawing, Circuit Side

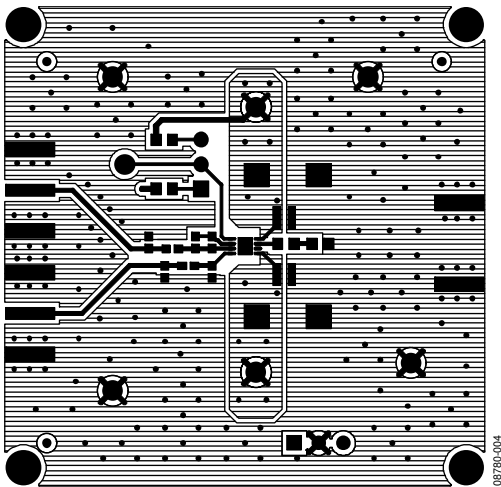

Figure 4. Board Layout Pattern, Component Side

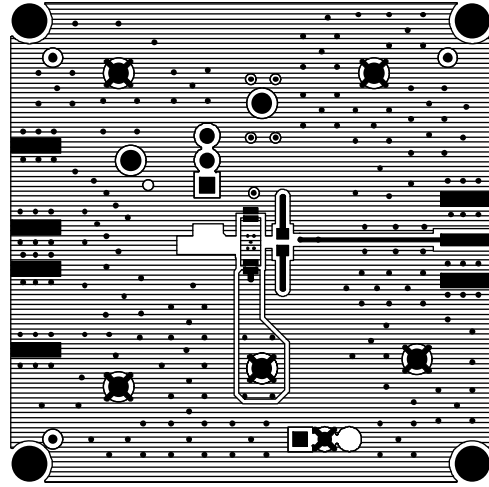

Figure 6. Board Layout Pattern, Circuit Side

ESD CAUTION

	<p>ESD (electrostatic discharge) sensitive device. Charged devices and circuit boards can discharge without detection. Although this product features patented or proprietary protection circuitry, damage may occur on devices subjected to high energy ESD. Therefore, proper ESD precautions should be taken to avoid performance degradation or loss of functionality.</p>
--	---

Evaluation boards are only intended for device evaluation and not for production purposes. Evaluation boards are supplied “as is” and without warranties of any kind, express, implied, or statutory including, but not limited to, any implied warranty of merchantability or fitness for a particular purpose. No license is granted by implication or otherwise under any patents or other intellectual property by application or use of evaluation boards. Information furnished by Analog Devices is believed to be accurate and reliable. However, no responsibility is assumed by Analog Devices for its use, nor for any infringements of patents or other rights of third parties that may result from its use. Analog Devices reserves the right to change devices or specifications at any time without notice. Trademarks and registered trademarks are the property of their respective owners. Evaluation boards are not authorized to be used in life support devices or systems.