

**STRAIGHT JACK CLAMP TYPE
CABLE .141**

R161.227.000
SERIES N

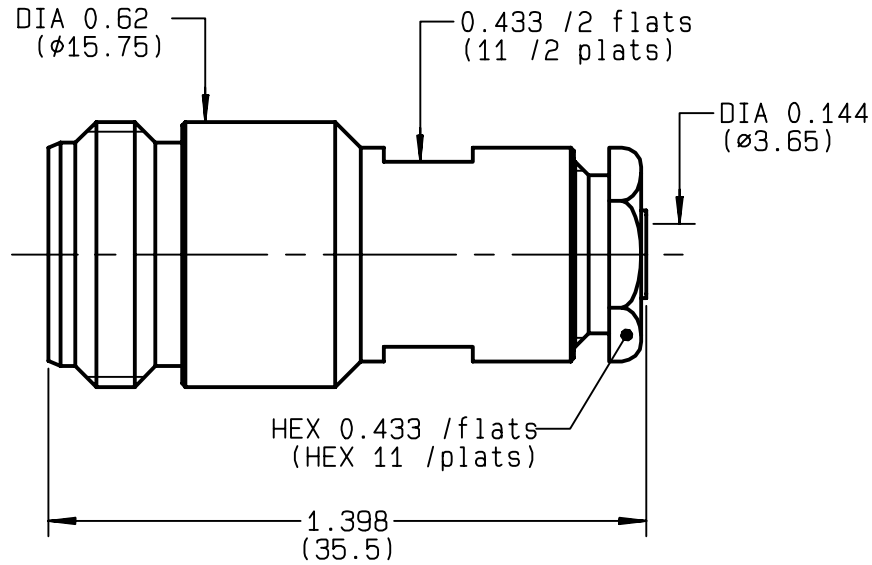

NOMINAL IMPEDANCE	50 Ω	CABLES : BELN 1673A HC80000-3 KS 2 RG 402 SUCOFORM 141
FREQUENCY RANGE	0-11 GHz	
TEMPERATURE RATING	-55/+105 °C	
V.S.W.R	1.15 + x F(GHz)Maxi	
RF INSERTION LOSS	0.048 √F(GHz) dB Maxi	
VOLTAGE RATING	335 Veff Maxi	
DIELECTRIC WITHSTANDING VOLTAGE	1000 Veff Mini	
INSULATION RESISTANCE	5000 MΩMini	
HERMETIC SEAL	NA Atm.cm ³ /s	
LEAKAGE (pressurized only)	NA	
MECHANICAL DURABILITY	500 Cycles	OTHERS CHARACTERISTICS
WEIGHT	32 gr	CABLE RETENTION 500 N Mini
SPECIFICATION		CENTER CONTACT RETENTION
		Axial force - mating end NA N Mini
		Axial force - opposite end NA N Mini
		Torque NA cm.N Mini
		RECOMMENDED TORQUES
		Mating NA cm.N
		Panel nut NA cm.N
		Clamp nut 450 cm.N

CONNECTOR PARTS	MATERIALS	FINISH	(all values are given in micrometers)
BODY	BRASS	BBR 2	
OUTER CONTACT	BRASS	BBR 2	
CENTER CONTACT	BERYLLIUM COPPER	GOLD 0.5 OVER NICKEL 2	
INSULATOR	PTFE	-	
GASKET	-	-	
OTHERS PIECES	BRASS	BBR 2	

ISSUE	CREATION DATE	FILE PART-NUMBER
9726R00	15/10/1992	



BONOMINI

The information given here is subject to change without notice. Design changes may be in order to improve the product.

Connect to the future



R161.227.000

ISSUE 9726R00 SERIES N

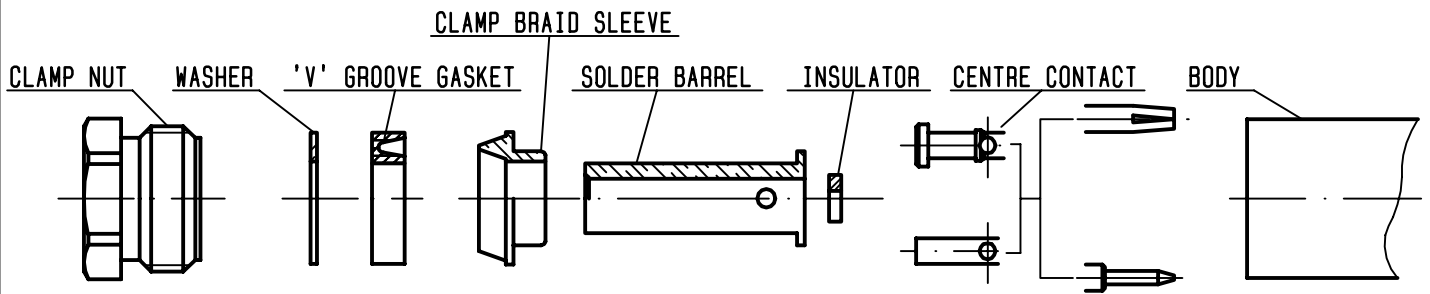

①

Take the tool kit : R 282 125 010 .
Strip the dielectric of the cable .
Stripping tool cable : R 282 053 .
Trim cable centre conductor .
Trimmer : R 282 066 010 .
Clean the cable .

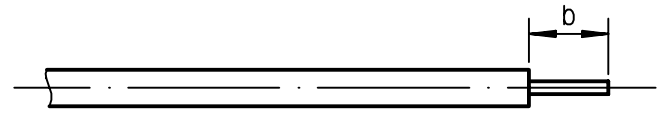

Stripping	a	b	c	d	e
inch	0	0.177 0	0	0	0
mm		4.5			

②

Slide the clamp nut , the washer , the 'V'groove gasket , the clamp braid sleeve and the solder barrel onto the cable .
Position solder barrel flush against solder barrel gauge and solder to the cable or align with outer the conductor (b) .
Solder barrel gauge : R 282 744 320 .

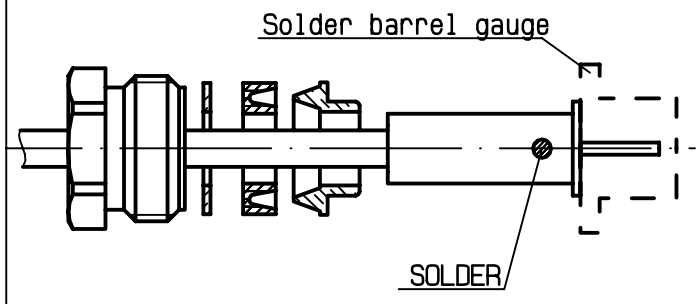

③

Once cooled , remove the solder barrel gauge .
Cut the dielectric flush to clamp braid sleeve .
Slide the insulator onto the cable inner conductor .
Slide the centre contact onto the cable inner conductor against insulator .
Fit the cable assembly onto the soldering jig R 282 740 030 and the positioner R 282 744 260 .
Tighten cable and solder the centre contact .

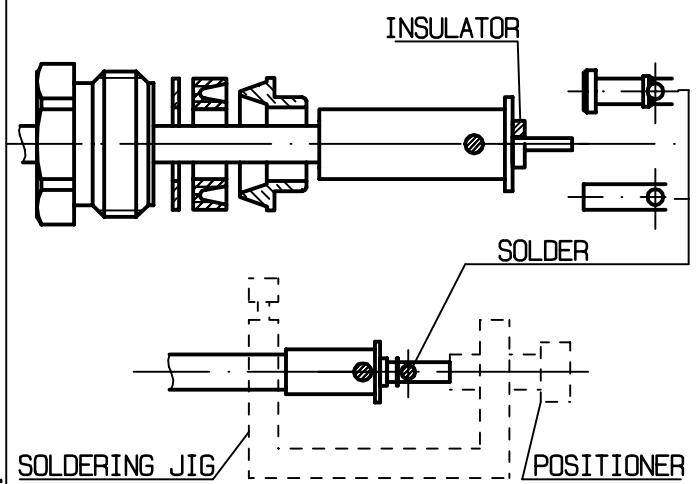

④

Screw sub-assembly into the connector body .
(recommended coupling torque 22.12 in.lb)
-
-

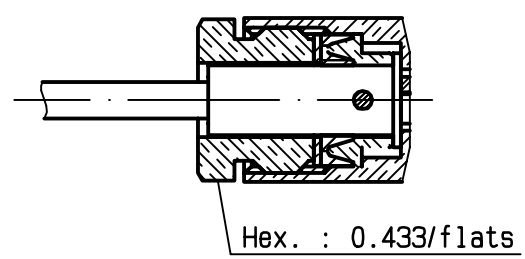

BONOMINI