

ENG. NO

EDP NO.

SIMILAR ITEM

CADFILE NO.

DO NOT SCALE DRAWING

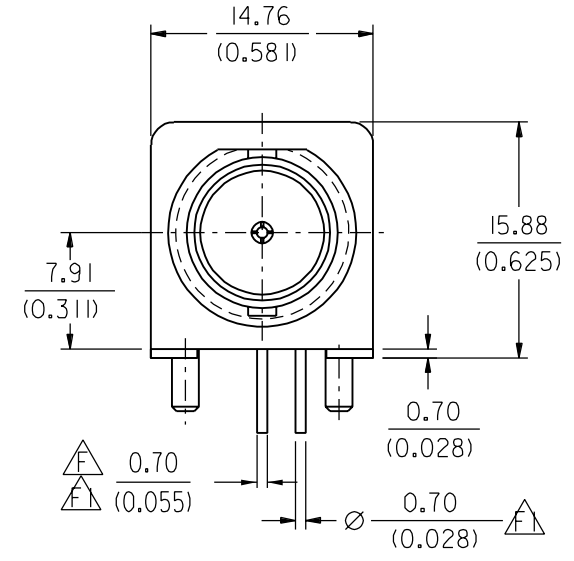
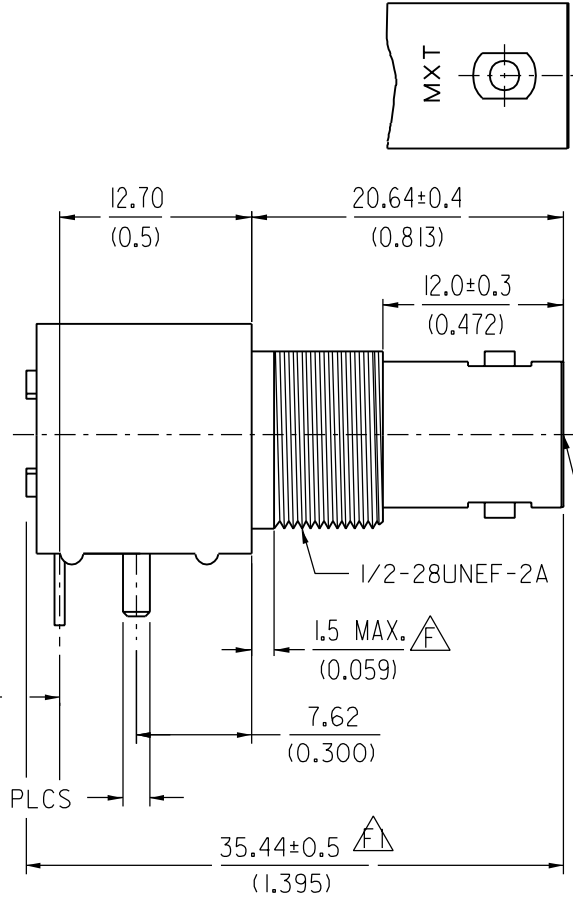
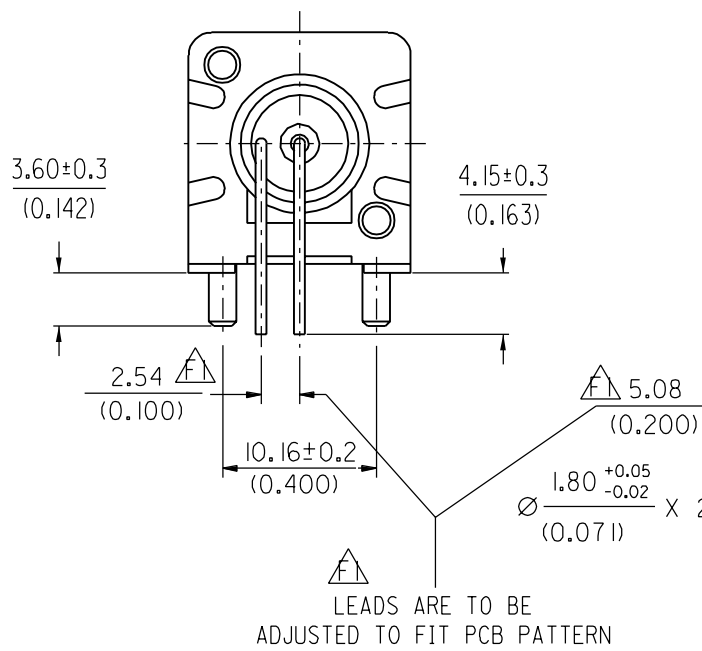
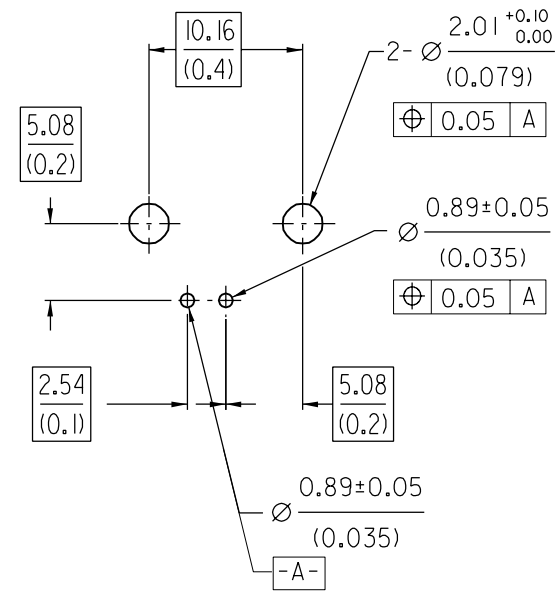

- CONSTRUCTION:**
- △ BODY-----ZINC ALLOY
 - △ HOUSING-----POLYESTER BUTYLENE TEREPHTHALATE (WHITE)
 - CENTER CONTACT----PHOSPHOR BRONZE
 - DIELECTRIC-----POLYPROPYLENE (94V2)
 - MOUNTING POST-----BRASS
 - SOLDER TAIL-----COPPER OVER STEEL WIRE
 - LOCK WASHER -----PHOSPHOR BRONZE
 - NUT-----BRASS

- FINISH:**
- △ BODY-----NICKEL PLATING
 - △ CENTER CONTACT----GOLD FLASH
 - SOLDER TAIL-----TIN PLATING
 - MOUNTING POST-----TIN PLATING
 - LOCK WASHER -----NICKEL PLATING
 - NUT-----NICKEL PLATING

MECHANICAL & ELECTRICAL CHARACTERISTICS:
PER PRODUCT SPECIFICATION: PS-73598-0050

MATERIAL & FINISH CHARACTERISTICS:
PER PRODUCT SPECIFICATION: PS-73598-0050

PACKAGING:
TRAY PACKAGING

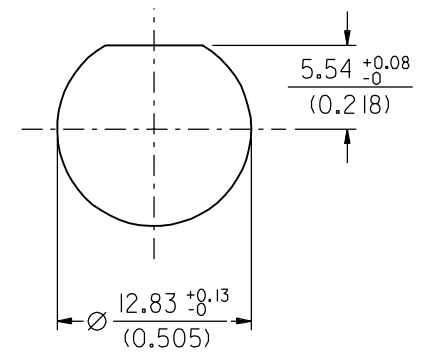
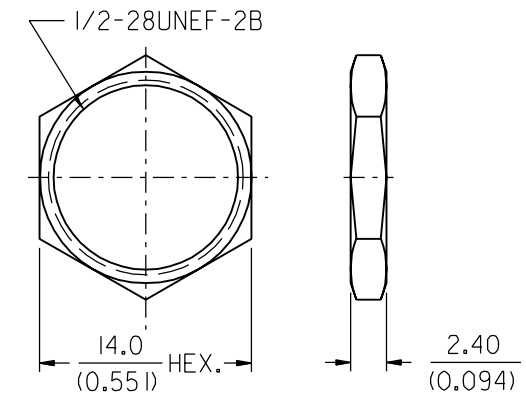
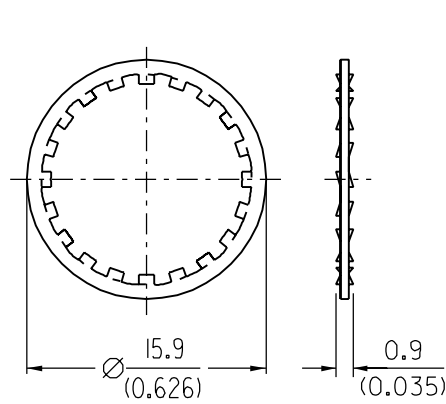

					MATERIAL :	SEE NOTES	MOLEX TAIWAN LTD. (R.F. DIVISION)
					FINISH :	SEE NOTES	
					SCALE :	2:1 UNIT : mm(INCH)	
					DRAWN BY :	Lilly 92/01/23	GENERAL TOLERANCES ANGLE : ± 3° DIM. ± 0.25 (±.01)
F1	CHANGE DIM.	0891		96/10/14	CHK'D BY :		DRW. NO.: SDA-73138-5013 REV F1
F	CONVERT TO NEW FORMAT	0637	Lillian	95/09/25	APPR'D BY :		TITLE : 50 OHMS BNC R/A PCB RECEPTACLE (MOLDED)
LTR	REVISION RECORD	ECN	DR	DATE	STANDARD ITEM	<input type="checkbox"/> YES <input checked="" type="checkbox"/> NO	SHEET OF

ENG. NO

EDP NO.

SIMILAR ITEM

CADFILE NO.

DO NOT SCALE DRAWING

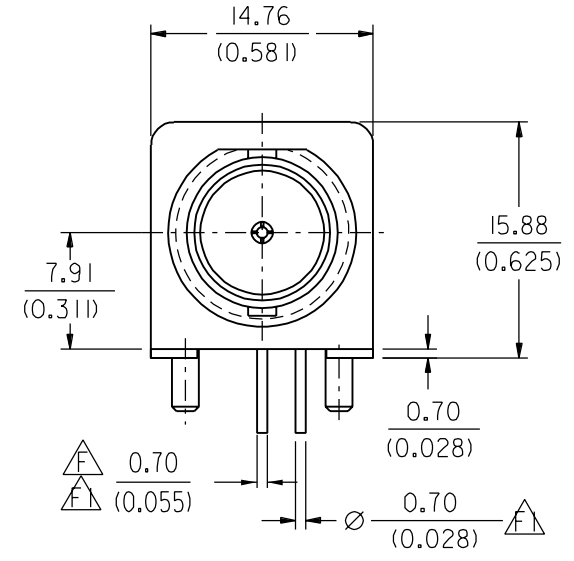
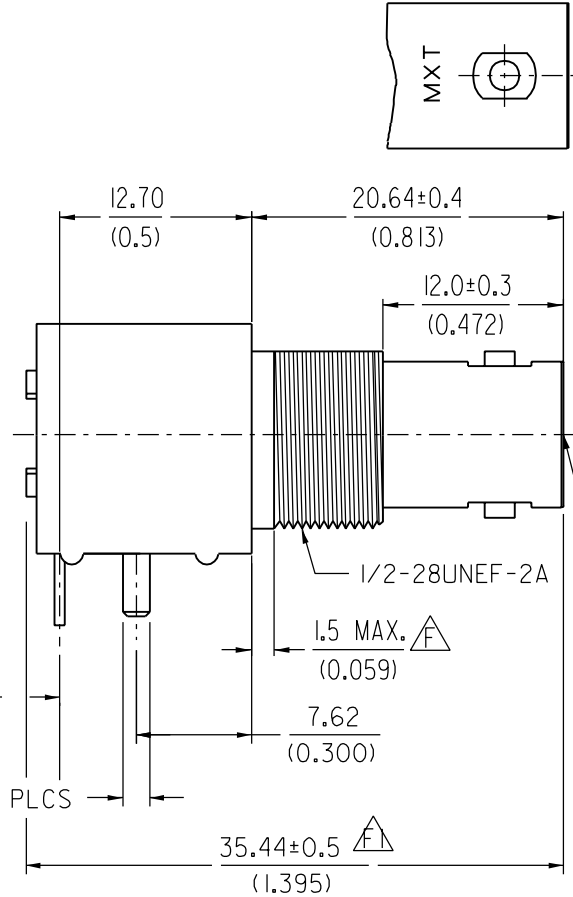
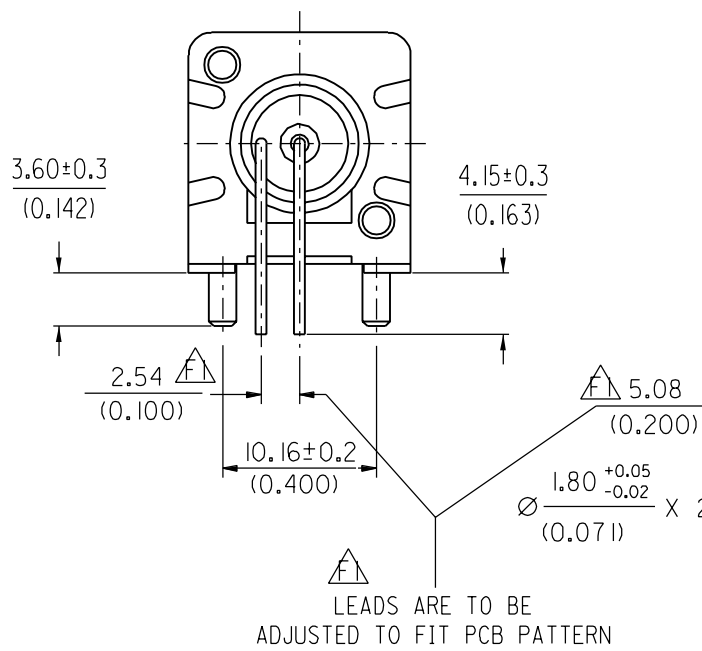
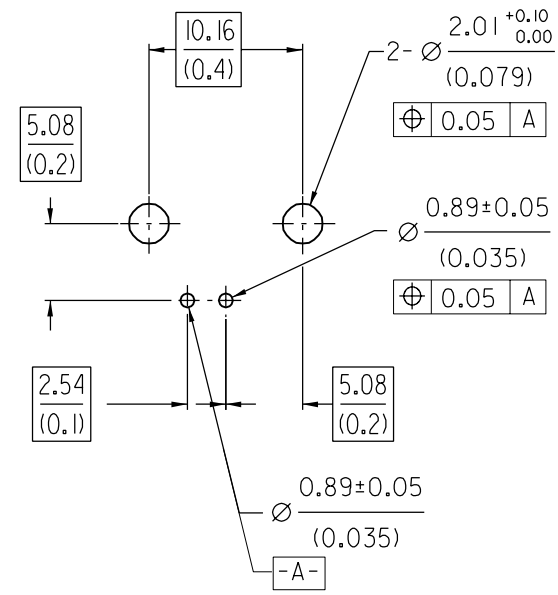

CONSTRUCTION:

- △ BODY-----ZINC ALLOY
- △ HOUSING-----POLYESTER BUTYLENE TEREPHTHALATE (WHITE)
- CENTER CONTACT----PHOSPHOR BRONZE
- DIELECTRIC-----POLYPROPYLENE (94V2)
- MOUNTING POST-----BRASS
- SOLDER TAIL-----COPPER OVER STEEL WIRE
- LOCK WASHER -----PHOSPHOR BRONZE
- NUT-----BRASS

FINISH:

- △ BODY-----NICKEL PLATING
- △ CENTER CONTACT----GOLD FLASH
- SOLDER TAIL-----TIN PLATING
- MOUNTING POST-----TIN PLATING
- LOCK WASHER -----NICKEL PLATING
- NUT-----NICKEL PLATING

MECHANICAL & ELECTRICAL CHARACTERISTICS:
PER PRODUCT SPECIFICATION: PS-73598-0050

MATERILA & FINISH CHARACTERISTICS:
PER PRODUCT SPECIFICATION: PS-73598-0050

PACKAGING:
TRAY PACKAGING

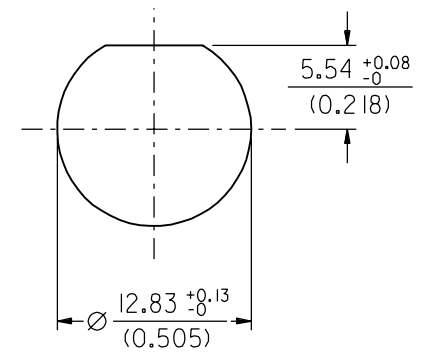
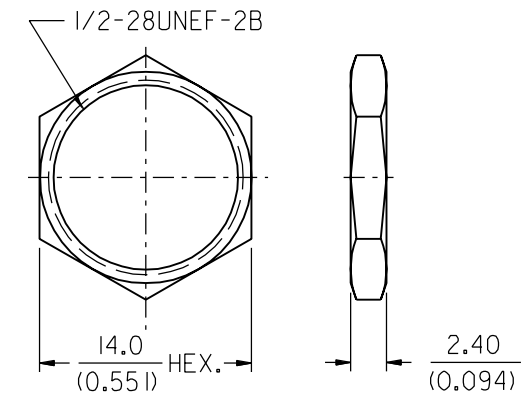
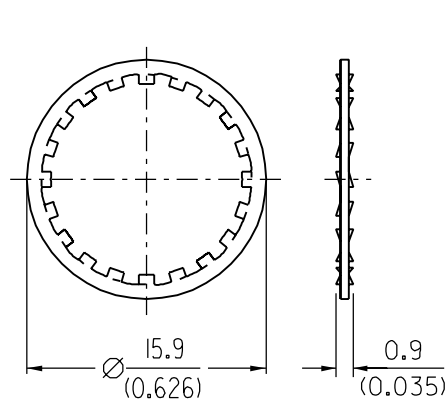

					MATERIAL :	SEE NOTES	MOLEX TAIWAN LTD. (R.F. DIVISION)
					FINISH :	SEE NOTES	
					SCALE :	2:1 UNIT : mm(INCH)	
					DRAWN BY :	Lilly 92/01/23	GENERAL TOLERANCES ANGLE : ± 3° DIM. ± 0.25 (±.01)
F1	CHANGE DIM.	0891		96/10/14	CHK'D BY :		DRW. NO.: SDA-73138-5013 REV F1
F	CONVERT TO NEW FORMAT	0637	Lillian	95/09/25	APPR'D BY :		TITLE : 50 OHMS BNC R/A PCB RECEPTACLE (MOLDED)
LTR	REVISION RECORD	ECN	DR	DATE	STANDARD ITEM	<input type="checkbox"/> YES <input checked="" type="checkbox"/> NO	SHEET OF