

| POSITIONS/ CONTACTS | A | | B | | C | |
|------------------------|------------|---------|------------|---------|------------|---------|
| | INCH±0.008 | MM±0.20 | INCH±0.016 | MM±0.40 | INCH±0.008 | MM±0.20 |
| 02/04 | 0.079 | 2.00 | 0.181 | 4.60 | NA | NA |
| 03/06 | 0.157 | 4.00 | 0.260 | 6.60 | 0.079 | 2.00 |
| 04/08 | 0.236 | 6.00 | 0.339 | 8.60 | 0.157 | 4.00 |
| 05/10 | 0.315 | 8.00 | 0.417 | 10.60 | 0.236 | 6.00 |
| 06/12 | 0.394 | 10.00 | 0.496 | 12.60 | 0.315 | 8.00 |
| 07/14 | 0.472 | 12.00 | 0.575 | 14.60 | 0.394 | 10.00 |
| 08/16 | 0.551 | 14.00 | 0.654 | 16.60 | 0.472 | 12.00 |
| 09/18 | 0.630 | 16.00 | 0.732 | 18.60 | 0.551 | 14.00 |
| 10/20 | 0.709 | 18.00 | 0.811 | 20.60 | 0.630 | 16.00 |
| 11/22 | 0.787 | 20.00 | 0.890 | 22.60 | 0.709 | 18.00 |
| 12/24 | 0.866 | 22.00 | 0.969 | 24.60 | 0.787 | 20.00 |
| 13/26 | 0.945 | 24.00 | 1.047 | 26.60 | 0.866 | 22.00 |
| 14/28 | 1.024 | 26.00 | 1.126 | 28.60 | 0.945 | 24.00 |
| 15/30 | 1.102 | 28.00 | 1.205 | 30.60 | 1.024 | 26.00 |
| 16/32 | 1.181 | 30.00 | 1.283 | 32.60 | 1.102 | 28.00 |
| 17/34 | 1.260 | 32.00 | 1.362 | 34.60 | 1.181 | 30.00 |
| 18/36 | 1.339 | 34.00 | 1.441 | 36.60 | 1.260 | 32.00 |
| 19/38 | 1.417 | 36.00 | 1.520 | 38.60 | 1.339 | 34.00 |
| 20/40 | 1.496 | 38.00 | 1.598 | 40.60 | 1.417 | 36.00 |
| 21/42 | 1.575 | 40.00 | 1.677 | 42.60 | 1.496 | 38.00 |
| 22/44 | 1.654 | 42.00 | 1.756 | 44.60 | 1.575 | 40.00 |
| 23/46 | 1.732 | 44.00 | 1.835 | 46.60 | 1.654 | 42.00 |
| 24/48 | 1.811 | 46.00 | 1.913 | 48.60 | 1.732 | 44.00 |
| 25/50 | 1.890 | 48.00 | 1.992 | 50.60 | 1.811 | 46.00 |
| 26/52 | 1.969 | 50.00 | 2.071 | 52.60 | 1.890 | 48.00 |
| 27/54 | 2.047 | 52.00 | 2.150 | 54.60 | 1.969 | 50.00 |
| 28/56 | 2.126 | 54.00 | 2.228 | 56.60 | 2.047 | 52.00 |
| 29/58 | 2.205 | 56.00 | 2.307 | 58.60 | 2.126 | 54.00 |
| 30/60 | 2.283 | 58.00 | 2.386 | 60.60 | 2.205 | 56.00 |
| 31/62 | 2.362 | 60.00 | 2.465 | 62.60 | 2.283 | 58.00 |
| 32/64 | 2.441 | 62.00 | 2.543 | 64.60 | 2.362 | 60.00 |
| 33/66 | 2.520 | 64.00 | 2.622 | 66.60 | 2.441 | 62.00 |
| 34/68 | 2.598 | 66.00 | 2.701 | 68.60 | 2.520 | 64.00 |
| 35/70 | 2.677 | 68.00 | 2.780 | 70.60 | 2.598 | 66.00 |
| 36/72 | 2.756 | 70.00 | 2.858 | 72.60 | 2.677 | 68.00 |
| 37/74 | 2.835 | 72.00 | 2.937 | 74.60 | 2.756 | 70.00 |
| 38/76 | 2.913 | 74.00 | 3.016 | 76.60 | 2.835 | 72.00 |
| 39/78 | 2.992 | 76.00 | 3.094 | 78.60 | 2.913 | 74.00 |
| 40/80 | 3.071 | 78.00 | 3.173 | 80.60 | 2.992 | 76.00 |

PART NUMBER CODING

xPPNxx2GFNx-M81RC

MOUNTING STYLES

P - SURFACE MOUNT W/ GUIDE POSTS
S - SURFACE MOUNT W/O GUIDE POSTS

NUMBER OF POSITIONS

(CONTACTS PER ROW, 02 THRU 40)

INSULATOR MATERIAL

N = NYLON 6T
OPERATING TEMPERATURE: -40°C TO +105°C
PORCESSING TEMP: WAVE/MANUAL SOLDERING
L = LCP
OPERATING TEMPERATURE: -40°C TO +125°C
PORCESSING TEMP: 260°C MAX FOR 10 SECONDS

| REVISIONS | | | | |
|-----------|---------|-------------------------------------|------------|----|
| REV. | ECO. NO | DESCRIPTION | DATE | BY |
| A | 2178 | INITIAL RELEASE | 02/14/2011 | LH |
| B | 2829 | ADD INSULATOR MATERIAL 'LCP' OPTION | 12/10/2014 | LH |

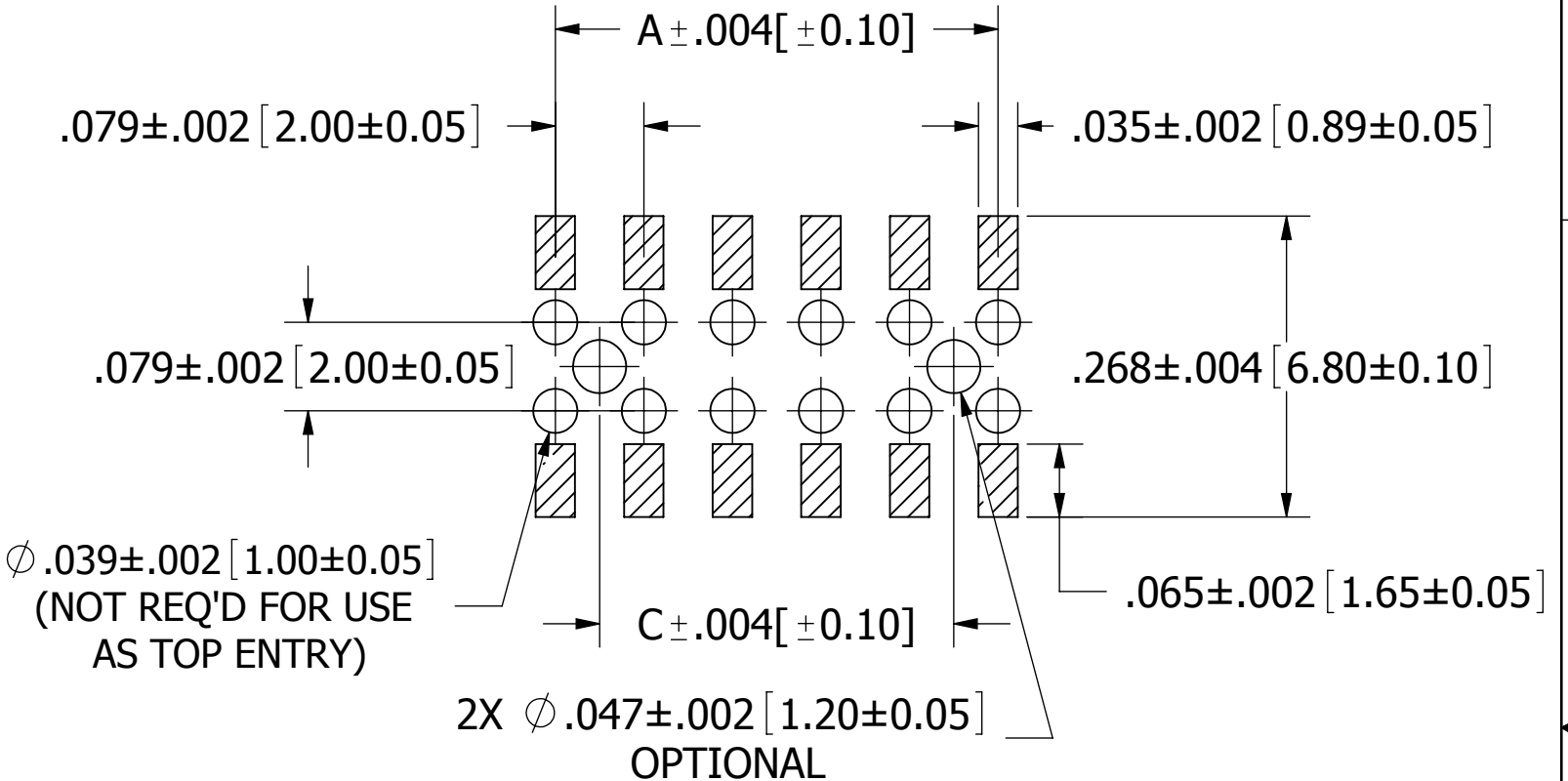
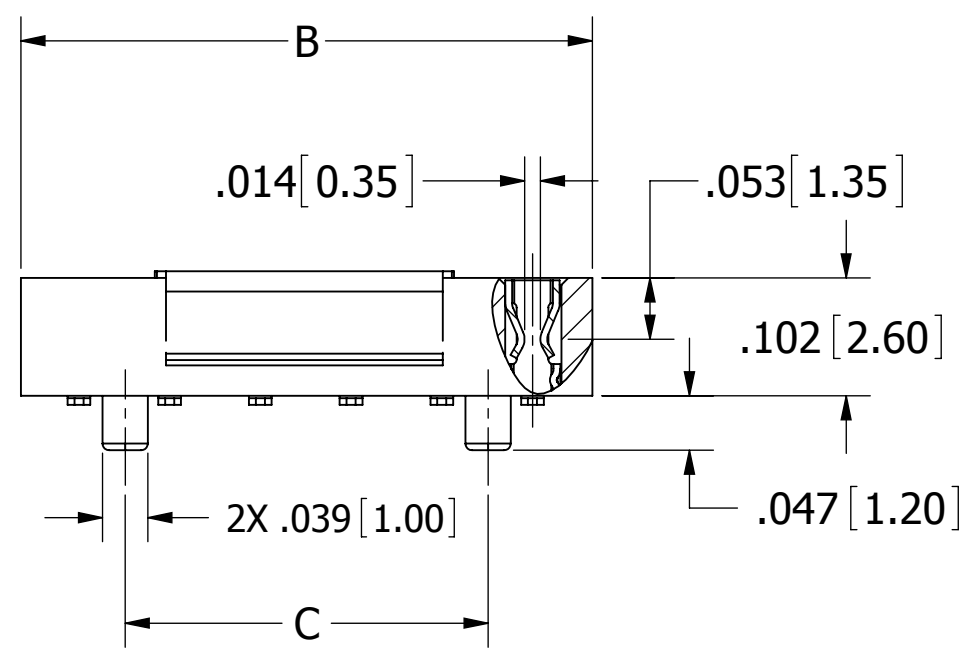
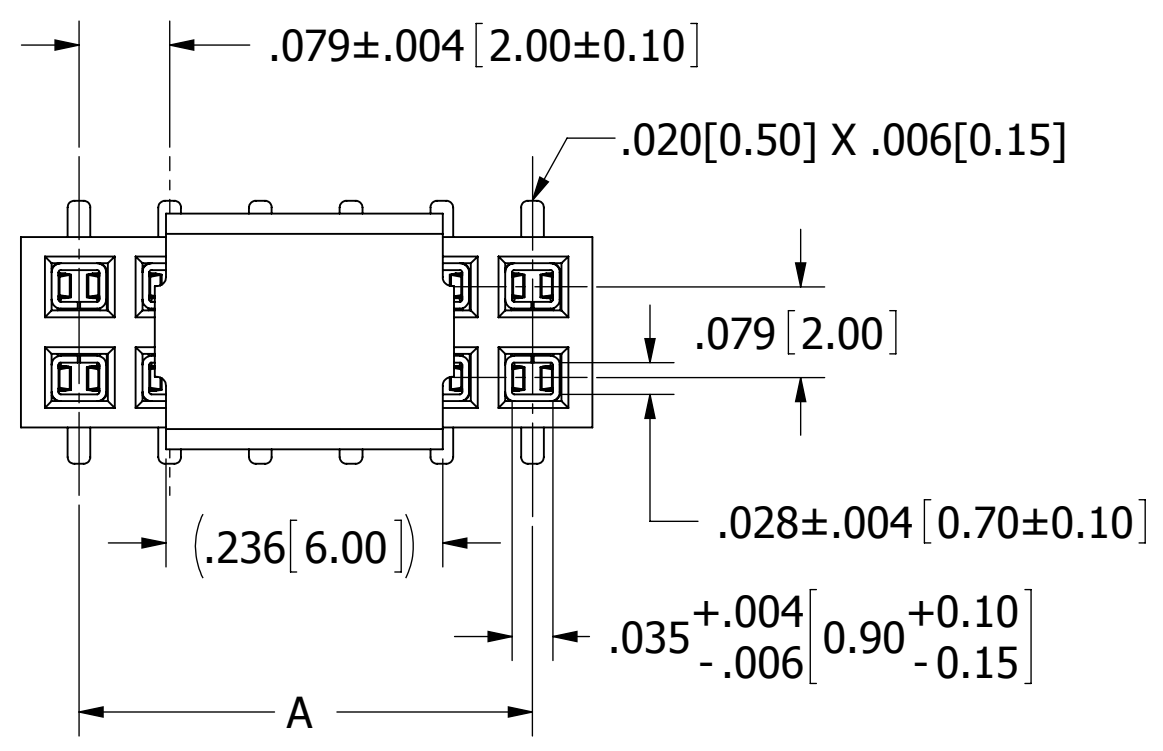
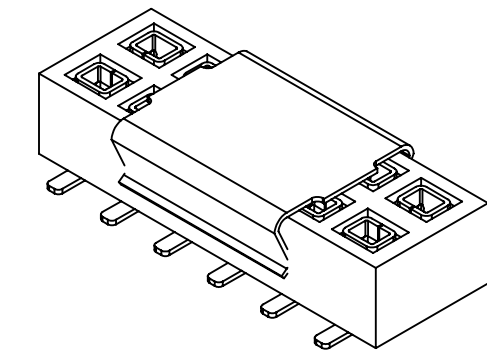

RECOMMENDED PCB LAYOUT

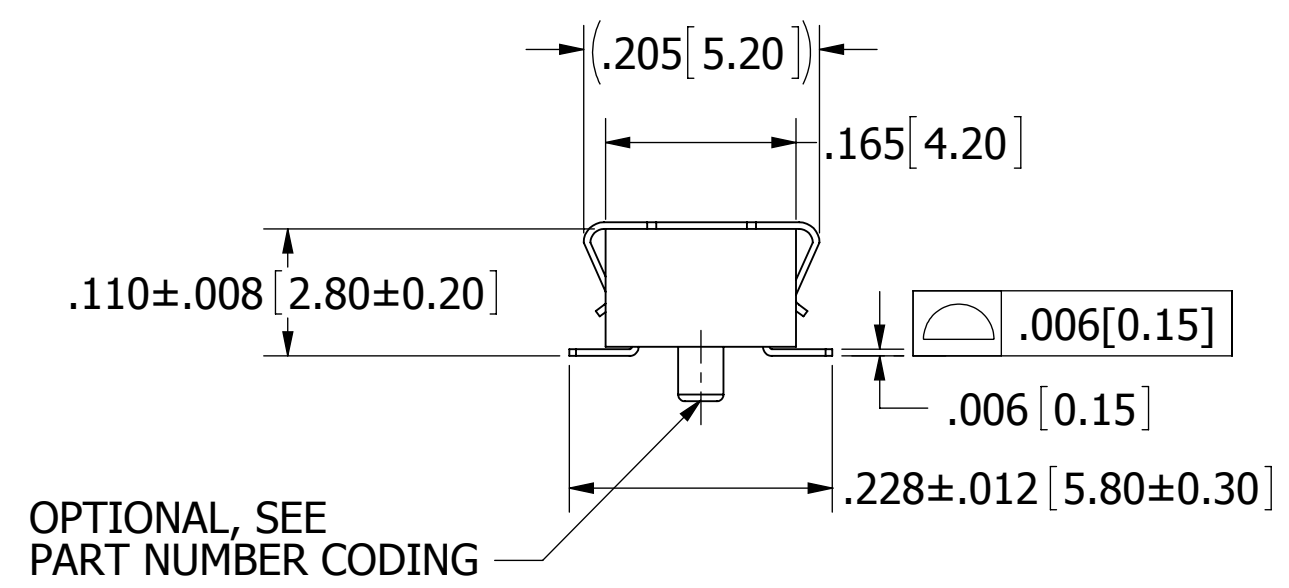

- NOTES:**
- INSULATOR MATERIAL: SEE PART NUMBER CODING, UL 94V-0, COLOR: BLACK
 - CONTACT MATERIAL: PHOSPHOR BRONZE
 - CONTACT PLATING: .000030" ~ .000050" NICKEL UNDERPLATE, GOLD FLASH OVERALL
 - CURRENT RATING: 2 AMPS
 - VOLTAGE RATING: 150V AC/DC
 - INSULATOR RESISTANCE: 5000 MEGOHMS MIN
 - CONTACT RESISTANCE: 20 MILLIOHMS MAX
 - DIELECTRIC WITHSTANDING: 500 VAC
 - OPERATING TEMPERATURE: SEE PART NUMBER CODING
 - MAX PROCESSING TEMP.: SEE PART NUMBER CODING
 - MODIFICATION: WITH PICK AND PLACE CAP IN TAPE & REEL

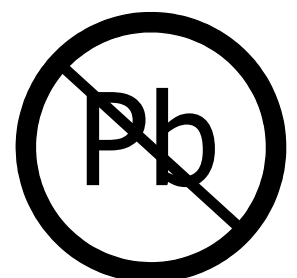

RoHS COMPLIANT

| | | | | |
|---|---|--------------|------|--|
| UNLESS OTHERWISE SPECIFIED: DIMENSIONS ARE IN INCHES [MM] | DRAWN | DATE | NAME | |
| | | 2/14/2011 | LH | |
| TOLERANCES: ANGULAR: X.X=± .012 [0.30] X.XX=± .008 [0.20] X.XXX=± .006 [0.15] | <small>THE INFORMATION HEREIN CONTAINS PROPRIETARY INFORMATION OF SULLINS ELECTRONICS AND IS NOT TO BE REPRODUCED, USED OR DISCLOSED TO OTHERS FOR ANY PURPOSE EXCEPT AS SPECIFICALLY AUTHORIZED IN WRITING BY AN OFFICER OF SULLINS ELECTRONICS.</small> | | | TITLE |
| | | | | HEADER FEMALE, .079"[2.0mm] PITCH, 2 ROWS, SMT |
| PART NUMBER | | | | xPPNxx2GFNx-M81RC |
| SIZE | CAGE CODE | DWG. NO. | REV | |
| C | 54453 | 11579 | B | |
| SCALE: 6:1 | | SHEET 1 OF 2 | | |

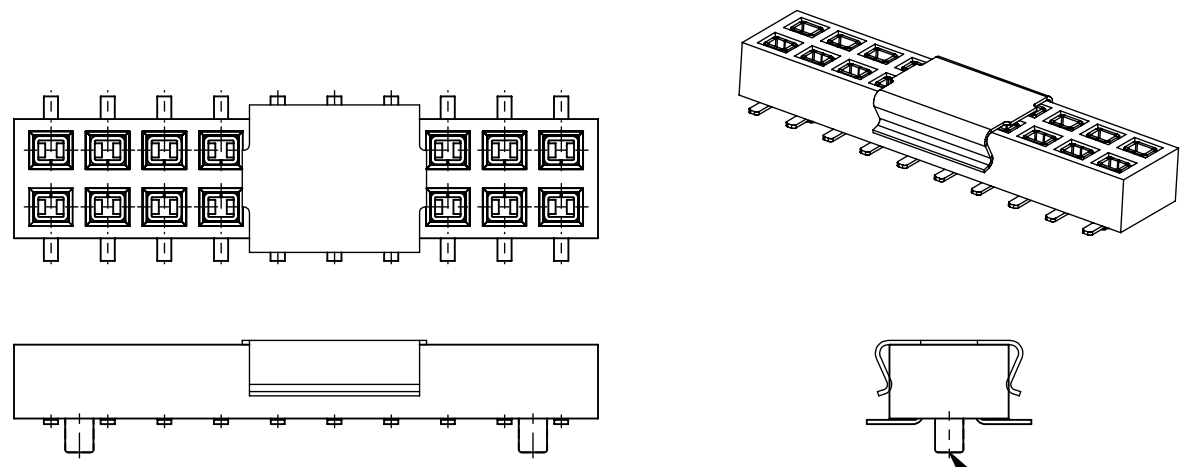

*NPNxx2GFNP-M81RC
 *NPNxx2GFNS-M81RC
 (10-POSITION AS SHOWN)
 (SEE T&R DIM TABLE AND NOTE 1)

OPTIONAL,
 SEE P/N CODING

**SEE ABOVE FOR PART

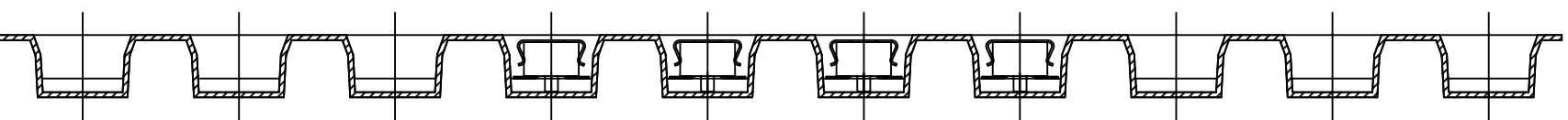
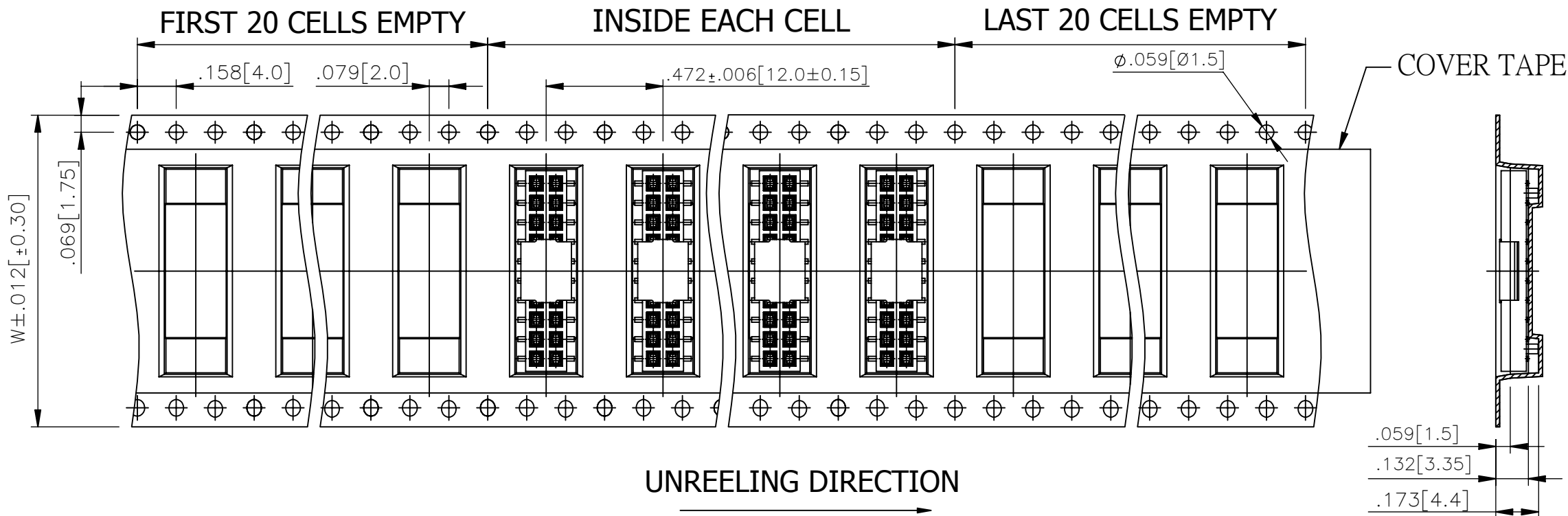

T & R DIMENSION TABLE

| POSITIONS/ CONTACTS | W | | A | |
|------------------------|-------|--------|-------|--------|
| | INCH | MM | INCH | MM |
| 02/04 | 0.472 | 12.00 | 0.669 | 17.00 |
| 03/06 - 04/08 | 0.630 | 16.00 | 0.827 | 21.00 |
| 05/10 - 08/16 | 0.945 | 24.00 | 1.142 | 29.00 |
| 09/18 - 11/22 | 1.260 | 32.00 | 1.457 | 37.00 |
| 12/24 - 17/34 | 1.732 | 44.00 | 1.929 | 49.00 |
| 18/36 - 23/46 | 2.205 | 56.00 | 2.402 | 61.00 |
| 24/48 - 28/56 | 2.835 | 72.00 | 3.031 | 77.00 |
| 29/58 - 34/68 | 3.465 | 88.00 | 3.661 | 93.00 |
| 35/70 - 40/80 | 4.094 | 104.00 | 4.291 | 109.00 |

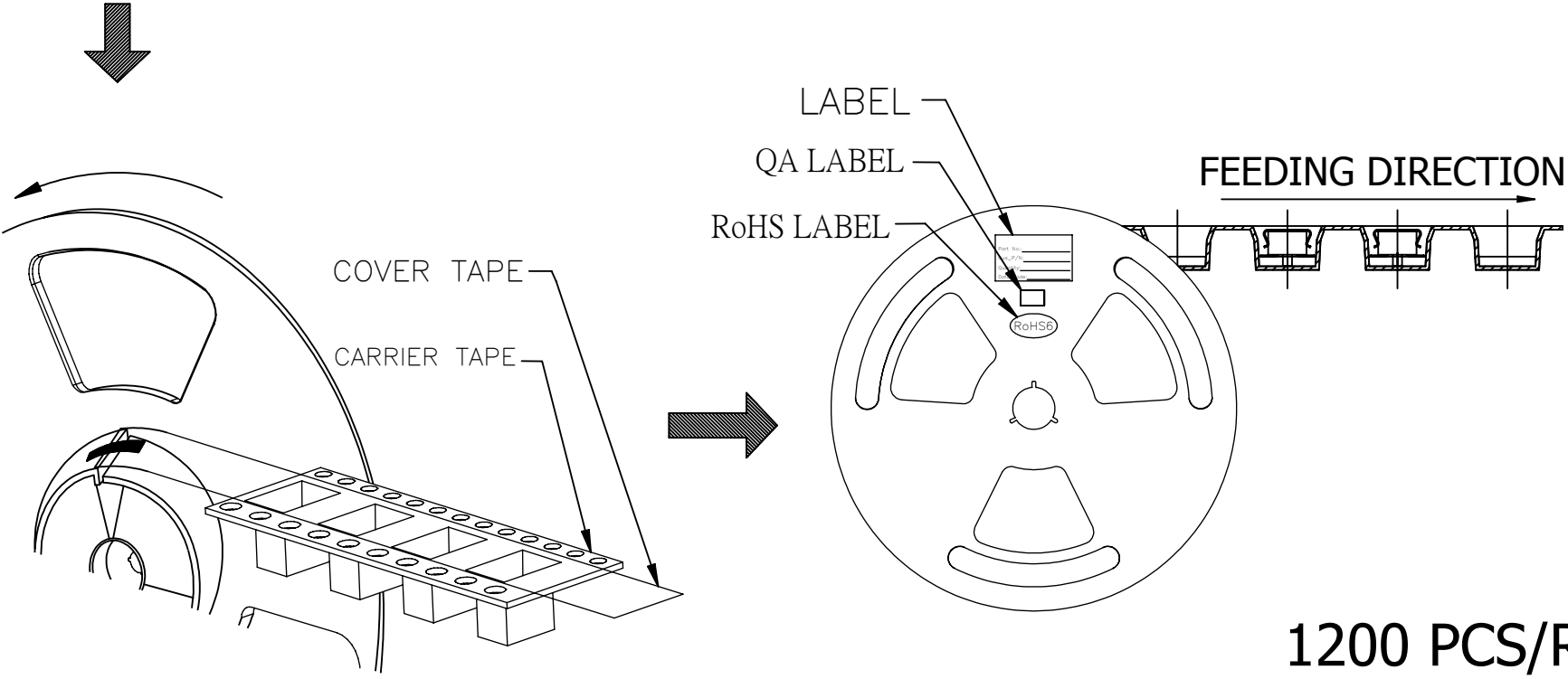
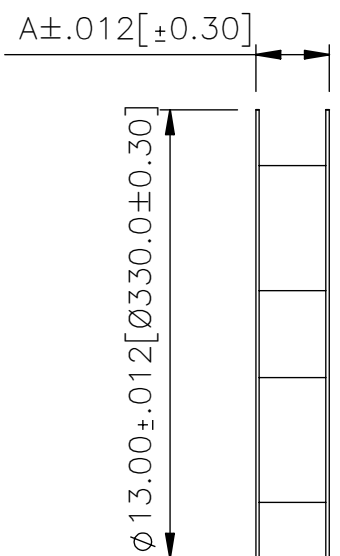

NOTE 1: WHEN THE CARRIER TAPE WIDTH IS EQUAL OR SMALLER THAN 24mm[.945"],
 Ø1.50mm[.059"] CARRIER HOLES ARE LOCATED ON SINGLE SIDE OF CARRIER TAPE.
 WHEN THE CARRIER TAPE WIDTH IS OVER THAN 24mm[.945"], Ø1.50mm[.059"]
 CARRIER HOLES ARE LOCATED ON DOUBLE SIDE OF CARRIER TAPE.

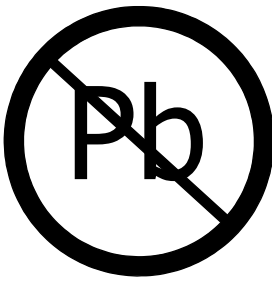

RoHS COMPLIANT

| | | | | | |
|--|-----------|--------------|-----------|------|---|
| UNLESS OTHERWISE SPECIFIED: DIMENSIONS ARE IN INCHES [MM] | | DRAWN | DATE | NAME | |
| TOLERANCES: ANGULAR: X.X=± .012 [0.30] X.XX=± .008 [0.20] X.XXX=± .006 [0.15] | | | 2/14/2011 | LH | |
| THE INFORMATION HEREIN CONTAINS PROPRIETARY INFORMATION OF SULLINS ELECTRONICS AND IS NOT TO BE REPRODUCED, USED OR DISCLOSED TO OTHERS FOR ANY PURPOSE EXCEPT AS SPECIFICALLY AUTHORIZED IN WRITING BY AN OFFICER OF SULLINS ELECTRONICS. | | | | | TITLE HEADER FEMALE, .079"[2.0mm] PITCH, 2 ROWS, SMT |
| PART NUMBER | | | | | xPPNxx2GFNx-M81RC |
| SIZE | CAGE CODE | DWG. NO. | REV | | |
| C | 54453 | 11579 | B | | |
| SCALE: 16:1 | | SHEET 2 OF 2 | | | |