



MXC6232xMP-B User Guide

MXC6232xMP-B

GENERAL DESCRIPTION

The MXC6232xMP-B provides a convenient and easy way to evaluate and prototype with the MXC6232xMP dual axes accelerometer. The accelerometer and passive components are SMT mounted on the board. Each pin of the MXC6232xMP SMT device is brought out to standard 0.10 inch on center connections on the sides of the prototyping board. Wires can either be soldered directly to the prototyping board or the DIP pins can be used with widely available breadboard kits.

For complete performance specifications of the MXC6232xMP refer to the MXC6232xMP datasheet.

PIN DESCRIPTION

Pin	Name	Description
P1-1	VDD	Supply Voltage 2.7 to 3.6 V
P1-2	NC	No Connect
P1-3	NC	No Connect
P1-4	GND	Ground
P2-1	NC	No Connect
P2-2	SDA	Serial Data Line for I2C Bus
P2-3	SCL	Serial Clock Line for I2C Bus
P2-4	NC	No Connect

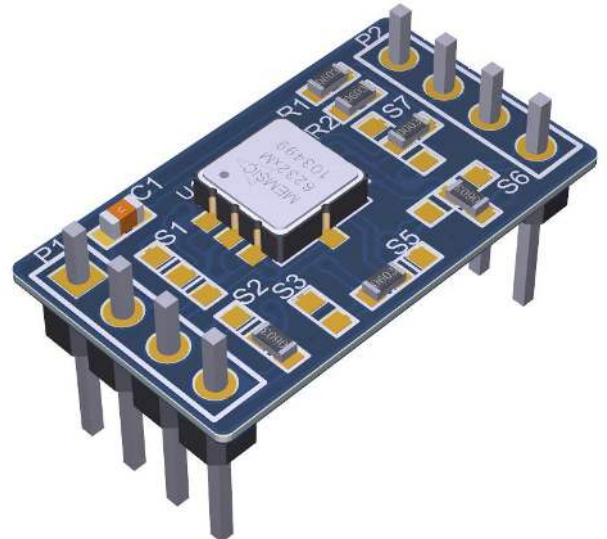

MXC6232xMP-B

PCB CONNECTION DIMENSIONS

SCHEMATIC OF THE MXC6232XMP-B

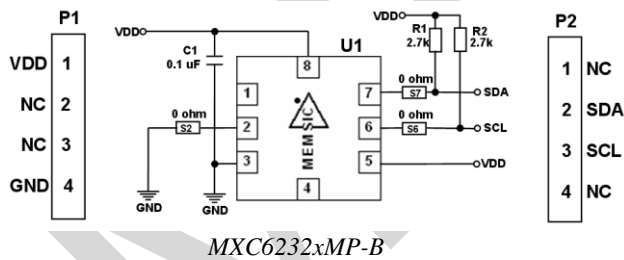

MXC6232xMP-B

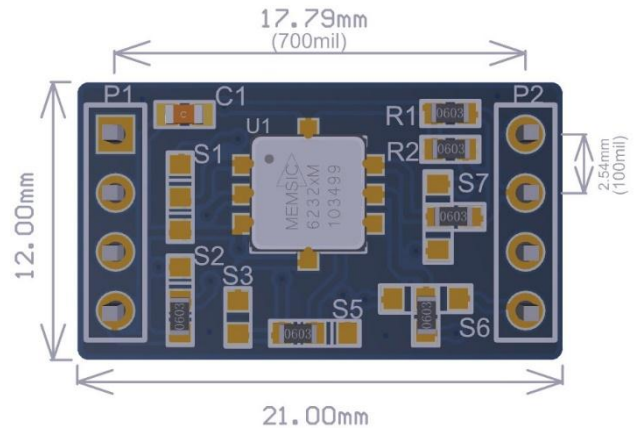

MXC6232xMP-B

Information furnished by MEMSIC is believed to be accurate and reliable. However, no responsibility is assumed by MEMSIC for its use, nor for any infringements of patents or other rights of third parties, which may result from its use. No license is granted by implication or otherwise under any patent or patent rights of MEMSIC.

MEMSIC Semiconductor (Wuxi) Co., Ltd.
 No.2 Xinhuihuan Road, Xinwu District, Wuxi, Jiangsu, China
 Tel: +86-510-66616668 Fax: +86-510-66616669
 www.memsic.com