

# Nylon Mounting Pads



## Features

- Tab keeps Cable Tie Head from Sliding Down behind Bundle during Vertical Applications and maintains Placement during Horizontal Applications
- Countersunk Screw Hole allows Cable Tie to easily Pass Over Screw Head
- 4-Sided Entry and Center Screw Hole Saves Positioning Time



## MP-01

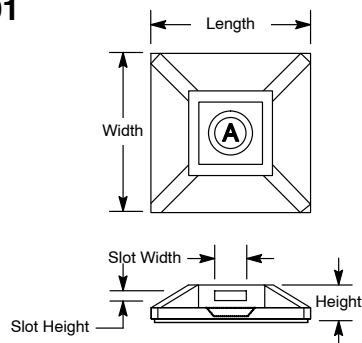

### Color Code Chart

0	Black	9	Natural
---	-------	---	---------

## Rubber Adhesive Mounting Pads

NTE Type No.	Square (in. / mm)	Height (in. / mm)	Slot Height (in. / mm)	Slot Width (in. / mm)	Screw Size	Qty. per Bag	Diag No.
04-MP750x	.740 / 18.79	.1875 / 4.76	.060 / 1.52	.210 / 5.33	#8	100	MP-01
04-MP1000x	.990 / 25.14	.198 / 5.03	.060 / 1.52	.210 / 5.33	#10	100	MP-01

## Acrylic Adhesive Mounting Pads

NTE Type No.	Square (in. / mm)	Height (in. / mm)	Slot Height (in. / mm)	Slot Width (in. / mm)	Screw Size	Qty. per Bag	Diag No.
04-MPA750x	.740 / 18.79	.1875 / 4.76	.060 / 1.52	.210 / 5.33	#8	100	MP-01
04-MPA1000x	.990 / 25.14	.198 / 5.03	.060 / 1.52	.210 / 5.33	#10	100	MP-01

## Non-Taped Mounting Pads

NTE Type No.	Square (in. / mm)	Height (in. / mm)	Slot Height (in. / mm)	Slot Width (in. / mm)	Screw Size	Qty. per Bag	Diag No.
04-MP750NTx	.740 / 18.79	.1875 / 4.76	.060 / 1.52	.210 / 5.33	#8	100	MP-01
04-MP1000NTx	.990 / 25.14	.198 / 5.03	.060 / 1.52	.210 / 5.33	#10	100	MP-01

Note 1. Replace "x" in device number with corresponding color code from the "Color Code Chart".

# Natural Nylon Identification Plates

## Features

- Allows Larger Print when Information and Visibility is Critical
- Increased Surface Area provides Twice the Area as Conventional Identification Cable Ties
- Orientation Variety Apply to Bundle Vertically or Horizontally



## IP-01

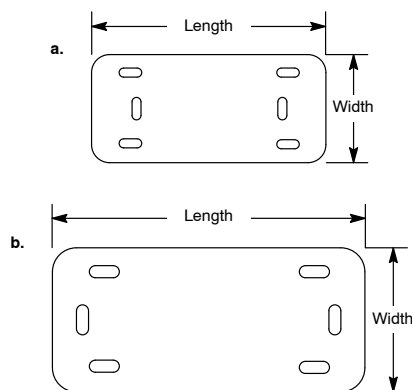

## Identification Plates

NTE Type No.	Length (in. / mm)	Height (in. / mm)	Thickness (in. / mm)	Slot Height (in. / mm)	Slot Width (in. / mm)	Qty. per Bag	Diag No.
04-IDP19	1.570 / 40.0	.787 / 20.0	.039 / 1.0	.080 / 2.03	.180 / 4.57	100	MP-01a
04-IDP29	2.360 / 60.0	.984 / 25.0	.039 / 1.0	.080 / 2.03	.180 / 4.57	100	MP-01b