

THIS DRAWING IS UNPUBLISHED. RELEASED FOR PUBLICATION .19  
 BY AMP INCORPORATED. ALL RIGHTS RESERVED.

LOC	DIST	REVISIONS					
		F	LTR	DESCRIPTION	DATE	DWN	APVD
BD	84		O	RLSE PER NPR 142, WAS 98-2198-3	11SEP98	-	-
			A	REVISED PER EC 0640-0070-99	27APR99	SW	RB

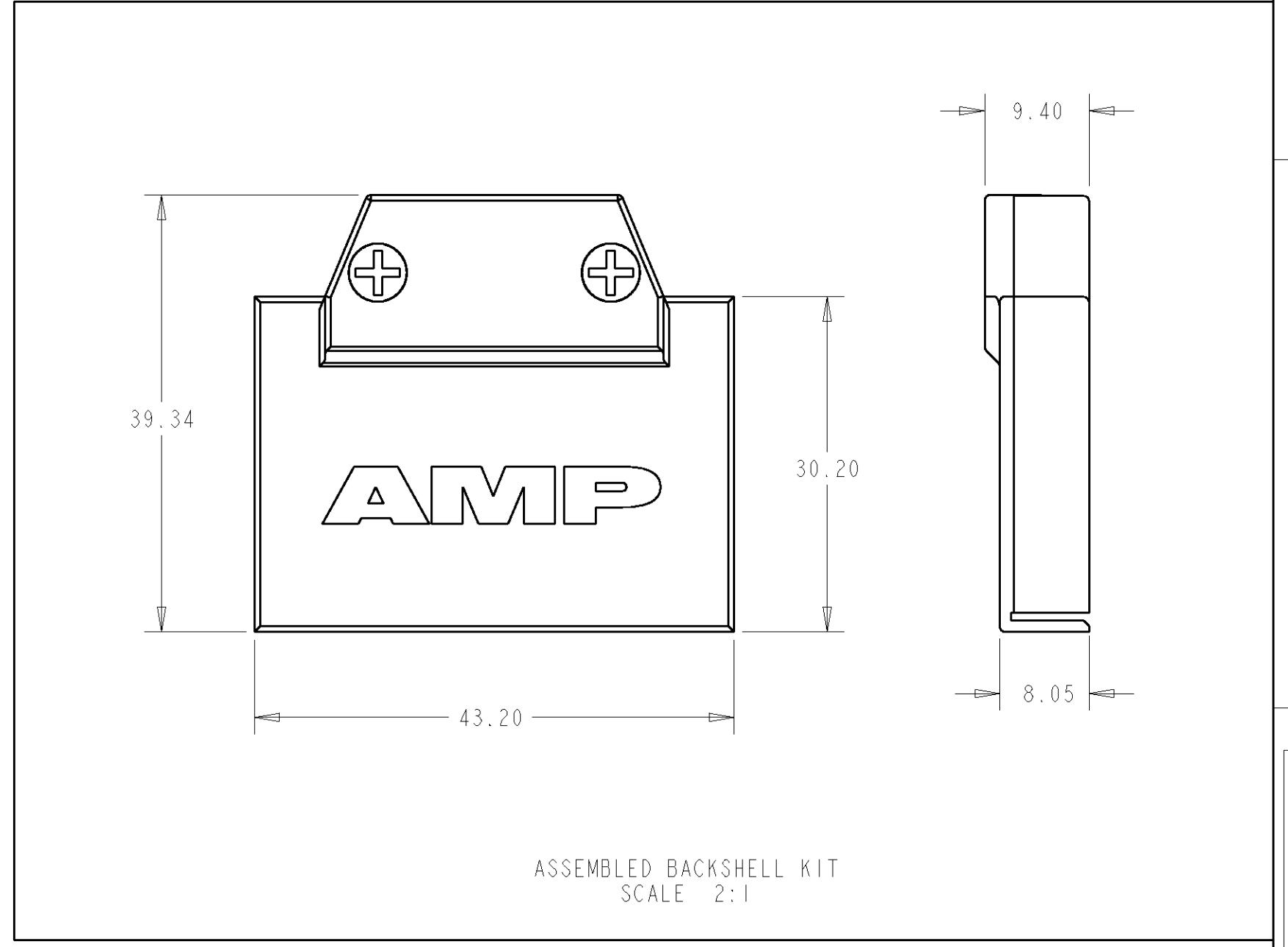
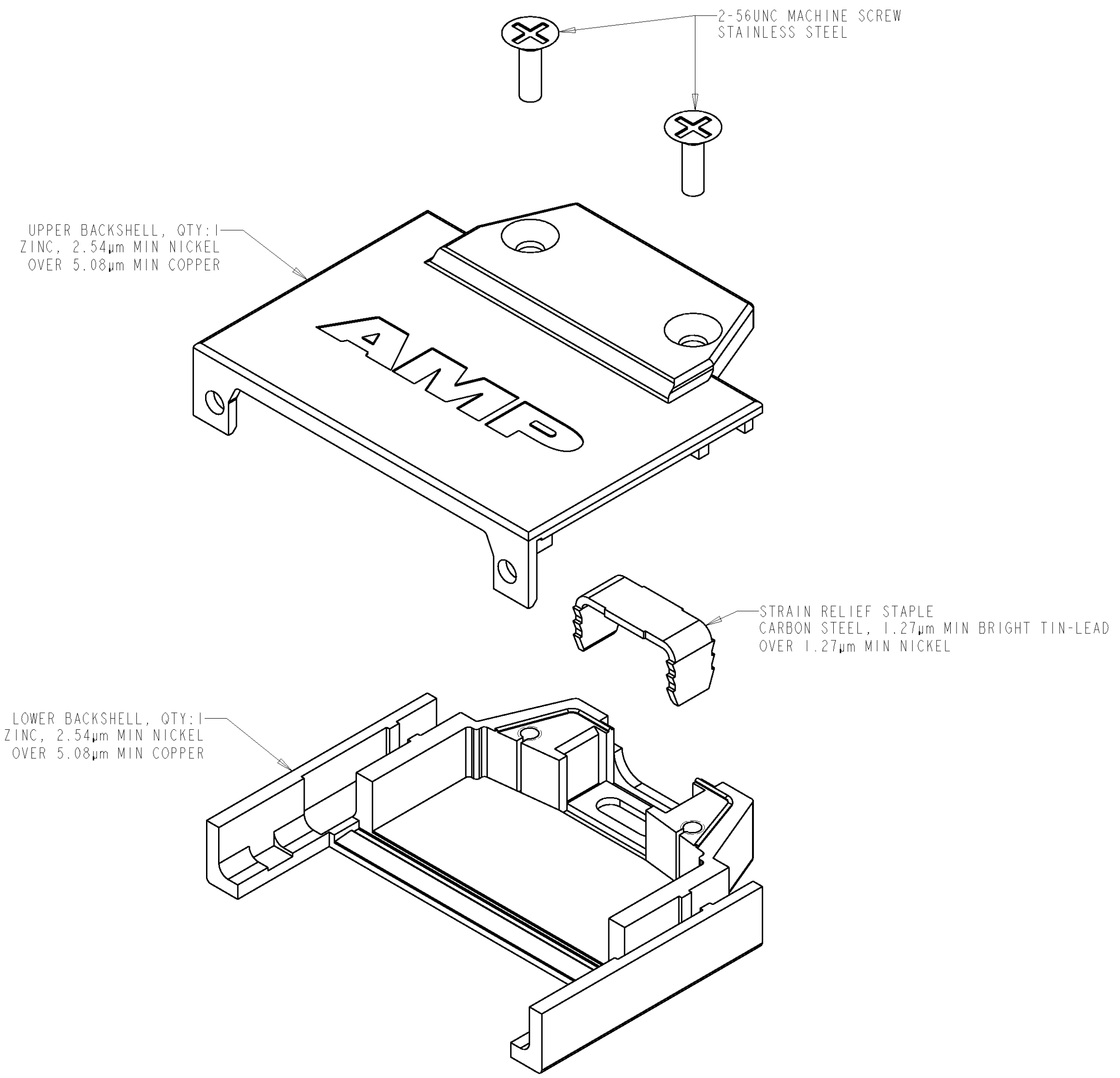

ASSEMBLY INSTRUCTIONS:

1. CABLE PREP LENGTH = 23.5mm
2. WIRE BRAID SHOULD BE ROLED BACK AND TRIMMED TO A MINIMUM OF 6.5mm
3. USE STRAIN RELIEF STAPLE TO ATTACH CABLE TO LOWER BACKSHELL
  - UPPER SURFACE OF STAPLE MUST BE BELOW THE MATING SURFACE OF THE TWO HALVES
  - INSERT STAPLE IN INCREMENTS, UNTIL THE WIRES BETWEEN THE TERMINATION POINT AND STAPLE DO NOT MOVE WHEN GENTLY TWISTING THE CABLE BUNDLE
4. PLACE JACKSCREWS IN PROPER LOCATION
5. ATTACH UPPER BACKSHELL USING THE TWO MACHINE SCREWS

788362-1  
 PART NUMBER

THIS DRAWING IS A CONTROLLED DOCUMENT FOR AMP INCORPORATED. IT IS SUBJECT TO CHANGE AND THE CONTROLLING ENGINEERING ORGANIZATION SHOULD BE CONTACTED FOR THE LATEST REVISION.		DWN S. WELDON 24APR98	AMP Incorporated Harrisburg, PA 17105-3608	
DIMENSIONS: mm		CHK R. STONE 24APR98	NAME BACKSHELL KIT, UNASSEMBLED, 68 POSN, CHAMP 0.8mm	
TOLERANCES UNLESS OTHERWISE SPECIFIED: 0 PLC ± 1 PLC ± 2 PLC ±0.13 3 PLC ± 4 PLC ± ANGLES ± FINISH		APVD T. BARR 24APR98		
MATERIAL SEE CALLOUTS		PRODUCT SPEC -	SIZE A2	CAGE CODE 00779
		APPLICATION SPEC -	DRAWING NO G-788362	RESTRICTED TO -
		WEIGHT -	SCALE 3:1	SHEET 1 OF 1
		CUSTOMER DRAWING	REV A	

788362