

# Automotive High-Side TMOS Driver

The MC33198 is a high-side TMOS driver, dedicated to automotive applications. It is used in conjunction with an external power MOSFET for high-side drive applications. The device can drive and protect a large variety of MOSFETs. The device has a CMOS compatible input control, charge pump to drive the MOSFET gate, and fault detection circuitry based on programmable  $V_{DS}$  monitoring to detect shorted loads. It also includes a programmable timer function to eliminate undesired switch off due to inrush currents, and a status pin which reports the output status of both on and off MOSFET states. The device uses few external components and offers an economical solution to large current high side switches. It also has PWM capability up to 1kHz.

## Features

- Designed for Automotive High Side Driver Application
- Works with a Wide Variety of N-Channel Power MOSFETs
- PWM Capability
- On Board Charge Pump Capable of Charging 25nF in less than 1ms with No External Components Required
- Drive Inductive Load with No External Clamp Circuitry Required
- CMOS Logic Compatible Input Control
- TMOS Over Current and Short Circuit Protection
- Fault Output to Report an MOSFET Overcurrent Condition
- Output Status Available when MOSFET is On or Off
- Extended Temperature Range from -40°C to 125°C
- Protected Against Automotive Transients with few External Components
- Overvoltage and Undervoltage Shutdown
- Pb-Free Packaging Designated by Suffix Code EF

33198

HIGH-SIDE TMOS DRIVER



D SUFFIX  
EF SUFFIX (PB-FREE)  
98ASB42564B  
8-PIN SOICN

ORDERING INFORMATION		
Device	Temperature Range ( $T_A$ )	Package
MC33198D	-40°C to 125°C	8 SOICN
MCZ33198EF/R2		

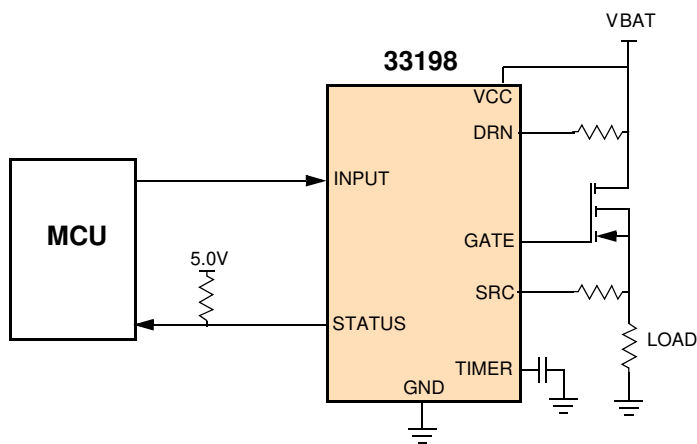

**Figure 1. 33198 Simplified Application Diagram**

Freescale Semiconductor, Inc. reserves the right to change the detail specifications, as may be required, to permit improvements in the design of its products.

© Freescale Semiconductor, Inc., 2007. All rights reserved.

### INTERNAL BLOCK DIAGRAM

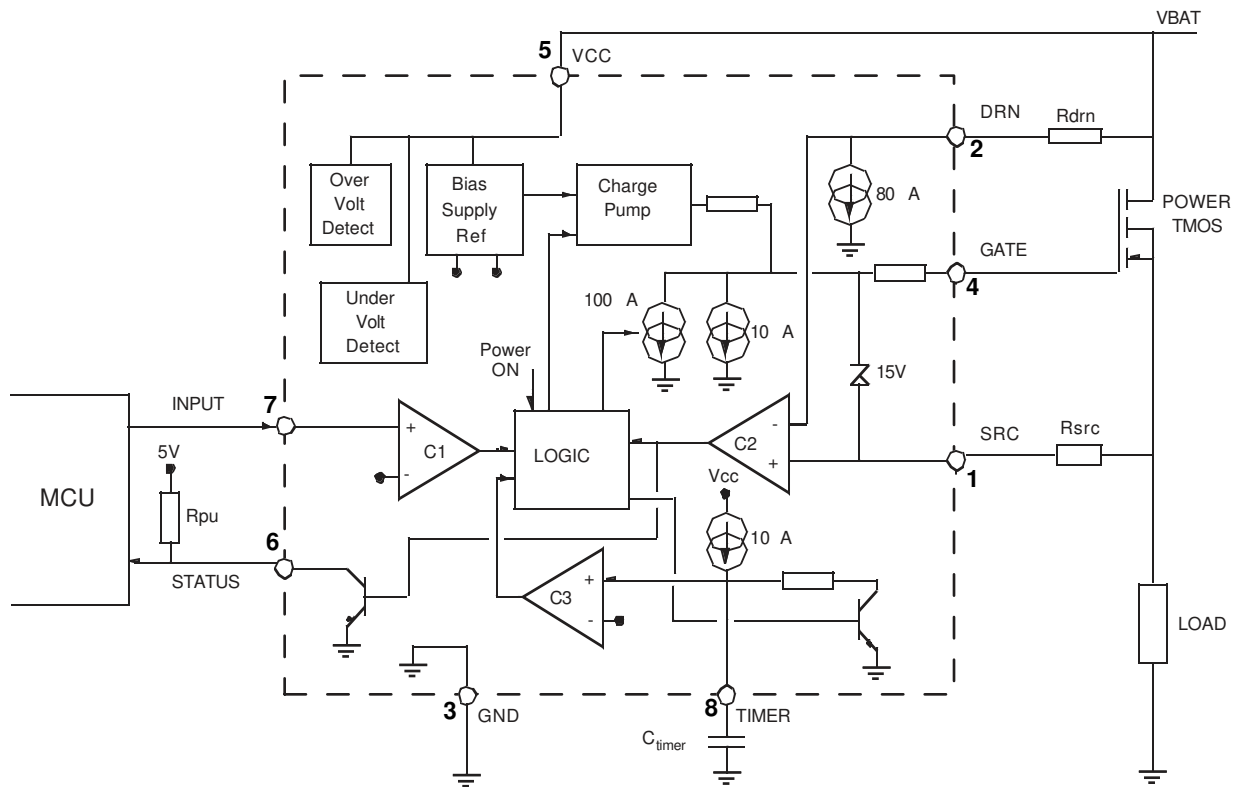

Figure 2. 33198 Simplified Internal Block Diagram and Typical Application

## PIN CONNECTIONS

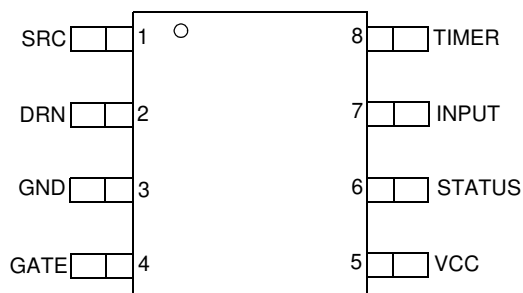

Figure 3. 33198 Pin Connections

Table 1. 33198 Pin Definitions

Pin Number	Pin Name	Formal Name	Definition
1	SRC	Source	Input to detect MOSFET/load status
2	DRN	Drain	Input to set overvoltage threshold
3	GND	Ground	Ground for the device
4	GATE	Gate	Output to control the gate of external MOSFET
5	VCC	VCC	Power for the device
6	STATUS	Status	Output signal for MOSFET status
7	INPUT	Input	Control input
8	TIMER	Timer	Inrush Current detection delay timer input

## ELECTRICAL CHARACTERISTICS

### MAXIMUM RATINGS

**Table 2. Maximum Ratings**

All voltages are with respect to ground unless otherwise noted. Exceeding these ratings may cause a malfunction or permanent damage to the device.

Ratings	Symbol	Value	Unit
<b>ELECTRICAL RATINGS</b>			
Power Supply Voltage	$V_{CC}$	- 0,6 to 60	V
TMOS Source Voltage	$V_{SRC}$	- 0,6 to 60	V
Comparator Threshold	$V_{DRN}$	- 0,6 to 60	V
Gate Output Voltage	$V_{GATE}$	- 0,6 to 25	V
Input Voltage	$V_{IN}$	- 0,6 to 25	V
Status	$V_{ST}$	- 0,6 to 10	V
ESD Voltage Capability <sup>(1)</sup>	$V_{ESD}$	+/-2000	V
<b>THERMAL RATINGS</b>			
Storage Temperature	$T_{STG}$	-55 to +150	°C
Operating Junction Temperature	$T_J$	-40 to +150	°C
<b>THERMAL RESISTANCE</b>			
Thermal Resistance J/A	$R_J$	145	°C
Peak Package Reflow Temperature During Reflow <sup>(2), (3)</sup>	$T_{PPRT}$	Note 3	°C

**Notes**

- ESD testing is performed in accordance with the Human Body Model (HBM) ( $C_{ZAP} = 100$  pF,  $R_{ZAP} = 1500$   $\Omega$ ), the Machine Model (MM) ( $C_{ZAP} = 200$  pF,  $R_{ZAP} = 0$   $\Omega$ ), and the Charge Device Model (CDM), Robotic ( $C_{ZAP} = 4.0$  pF).
- Pin soldering temperature limit is for 10 seconds maximum duration. Not designed for immersion soldering. Exceeding these limits may cause malfunction or permanent damage to the device.
- Freescale's Package Reflow capability meets Pb-free requirements for JEDEC standard J-STD-020C. For Peak Package Reflow Temperature and Moisture Sensitivity Levels (MSL), Go to [www.freescale.com](http://www.freescale.com), search by part number [e.g. remove prefixes/suffixes and enter the core ID to view all orderable parts. (i.e. MC33xxxD enter 33xxx)], and review parametrics.

### STATIC ELECTRICAL CHARACTERISTICS

**Table 3. Static Electrical Characteristics**

Characteristics noted under conditions  $7.0\text{ V} \leq V_{\text{SUP}} \leq 20\text{ V}$ ,  $-40^\circ\text{C} \leq T_A \leq 125^\circ\text{C}$ ,  $\text{GND} = 0\text{ V}$  unless otherwise noted. Typical values noted reflect the approximate parameter means at  $T_A = 25^\circ\text{C}$  under nominal conditions unless otherwise noted.

Characteristic	Symbol	Min	Typ	Max	Unit
<b>SRC PIN 1</b>					
Leakage Current	$I_{\text{L SRC}}$	-10	-	10	$\mu\text{A}$
<b>DRN PIN 2</b>					
Threshold Current	$I_{\text{THR}}$	54	81	102	$\mu\text{A}$
DRN Leakage, Input Off, VCC Pin Open	$I_{\text{LEAK}}$	-	-	10	$\mu\text{A}$
<b>GATE PIN 4</b>					
Output On Voltage at 1 ms (Charge Pump ON)	$V_{\text{ON}}$	$V_{\text{CC}} + 7.0$		$V_{\text{CC}} + 15$	V
Turn Off Current	$I_{\text{OUTN}}$	70	110	150	$\mu\text{A}$
with NO Over $V_{\text{DS}}$ condition and $V_{\text{OUT}} > 0.5\text{V}$	$I_{\text{OUTW}}$	5.0	10	15	$\mu\text{A}$
with Over $V_{\text{DS}}$ condition and $V_{\text{OUT}} > 0.5\text{V}$					
Output Off Voltage. (Charge Pump OFF and VCC Pin Open)	$V_{\text{OFF}}$	0.0	-	0.9	V
Gate Discharge Current. (VCC Pin Open)	$I_{\text{OFF}}$	-	5.0	-	$\mu\text{A}$
Turn On Time	$T_{\text{ON}}$				ms
CI = 25nF ; $7.0\text{V} < V_{\text{CC}} < 10\text{V}$ ; $V_{\text{OUT}} > V_{\text{CC}} + 7.0$		-	-	1.0	
CI = 25nF ; $10\text{V} < V_{\text{CC}} < 20\text{V}$ ; $V_{\text{OUT}} > V_{\text{CC}} + 10$		-	-	1.0	
<b>VCC PIN 5</b>					
Supply Voltage Range	$V_{\text{CC}}$	7.0	-	20	V
Quiescent Supply Current ; $I_{\text{N}} = 0\text{V}$	$I_{\text{CCQ}}$				mA
at $V_{\text{CC}} = 7.0\text{V}$		-	1.8	4.0	
at $V_{\text{CC}} = 20\text{V}$		-	2.8	6.0	
Supply Current ; $I_{\text{N}} = 5.0\text{V}$	$I_{\text{CC}}$	1.0	-	35	mA
Over Voltage Threshold	$V_{\text{OV}}$	22	28	34	V
Under Voltage Threshold	$V_{\text{UR}}$	-	6.0	7.0	V
<b>STATUS PIN 6</b>					
Output Voltage @ $I = 1\text{mA}$	$V_{\text{OL}}$	0.1	0.4	1.5	V
<b>INPUT Pin 7</b>					
Input Low Voltage	$V_{\text{IL}}$	-	-	1.5	V
Input High Voltage	$V_{\text{IH}}$	3.5	-	-	V
Input Hysteresis	$V_{\text{HYS}}$	0.8	-	-	V
Input Pull Down Resistor. $V_{\text{IN}} > 11\text{V}$	$R_{\text{IN}}$	20	36	100	$\text{k}\Omega$
Open Input Voltage	$V_{\text{IOP}}$	-	-	1.0	V

**Table 3. Static Electrical Characteristics (continued)**

Characteristics noted under conditions  $7.0\text{ V} \leq V_{\text{SUP}} \leq 20\text{ V}$ ,  $-40^\circ\text{C} \leq T_A \leq 125^\circ\text{C}$ ,  $\text{GND} = 0\text{ V}$  unless otherwise noted. Typical values noted reflect the approximate parameter means at  $T_A = 25^\circ\text{C}$  under nominal conditions unless otherwise noted.

Characteristic	Symbol	Min	Typ	Max	Unit
<b>TIMER PIN 8</b>					
Timer Current	$I_{\text{TIME}}$	7.0	10	14	$\mu\text{A}$
On Threshold	$V_{\text{HTH}}$	5.2	5.5	5.8	V
Discharge Current @ $V_{\text{PIN}8} = 5.0\text{V}$	$I_{\text{DISCH}}$	2.0	5.0	10	mA
Saturation Voltage @ $I_{\text{PIN}8} = 1\text{mA}$	$V_{\text{SAT}}$	-	0.15	0.4	V

### DYNAMIC ELECTRICAL CHARACTERISTICS

**Table 4. Dynamic Electrical Characteristics**

Characteristics noted under conditions  $7.0\text{ V} \leq V_{\text{SUP}} \leq 18\text{ V}$ ,  $-40^\circ\text{C} \leq T_A \leq 125^\circ\text{C}$ ,  $\text{GND} = 0\text{ V}$  unless otherwise noted. Typical values noted reflect the approximate parameter means at  $T_A = 25^\circ\text{C}$  under nominal conditions unless otherwise noted.

Parameter	Vcc = 7.0V	Vcc = 14V	Vcc = 21V	Unit
<b>TYPICAL RISE TIME (<math>t_R</math>) VERSUS GATE EXTERNAL CAPACITOR LOAD AND SUPPLY VOLTAGE (REFER TO Figure 4)</b>				
C = 1.0nF	15	7.0	10	$\mu\text{s}$
C = 3.0nF	60	25	40	$\mu\text{s}$
C = 10nF	140	80	90	$\mu\text{s}$
C = 30nF	730	270	340	$\mu\text{s}$
<b>TYPICAL FALL TIME (<math>t_F</math>) VERSUS GATE EXTERNAL CAPACITOR LOAD AND SUPPLY VOLTAGE (REFER TO Figure 4)</b>				
C = 1.0nF	150	230	280	$\mu\text{s}$
C = 3.0nF	430	800	950	$\mu\text{s}$
C = 10nF	1200	2300	2750	$\mu\text{s}$
C = 30nF	4800	8000	9200	$\mu\text{s}$

### TIMING DIAGRAMS

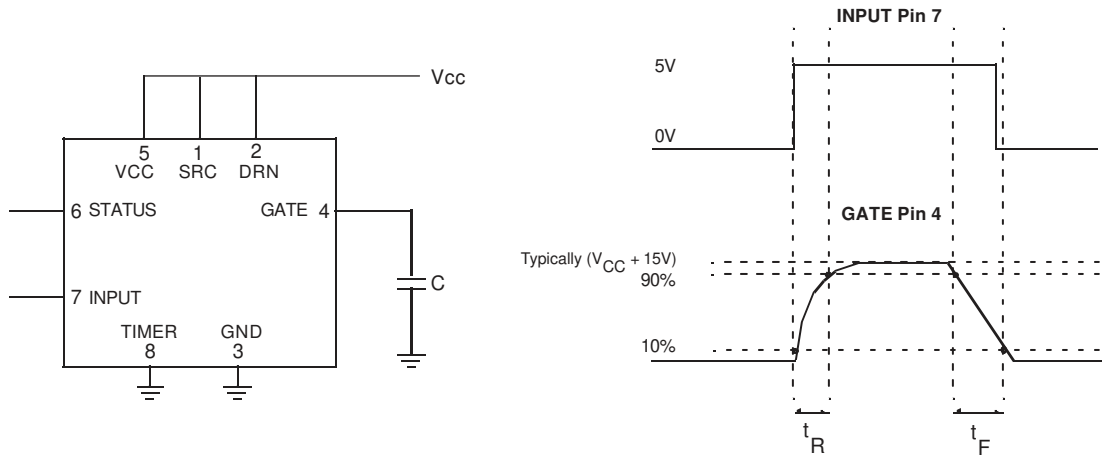

**Figure 4. Timing Measurements Test Schematic**

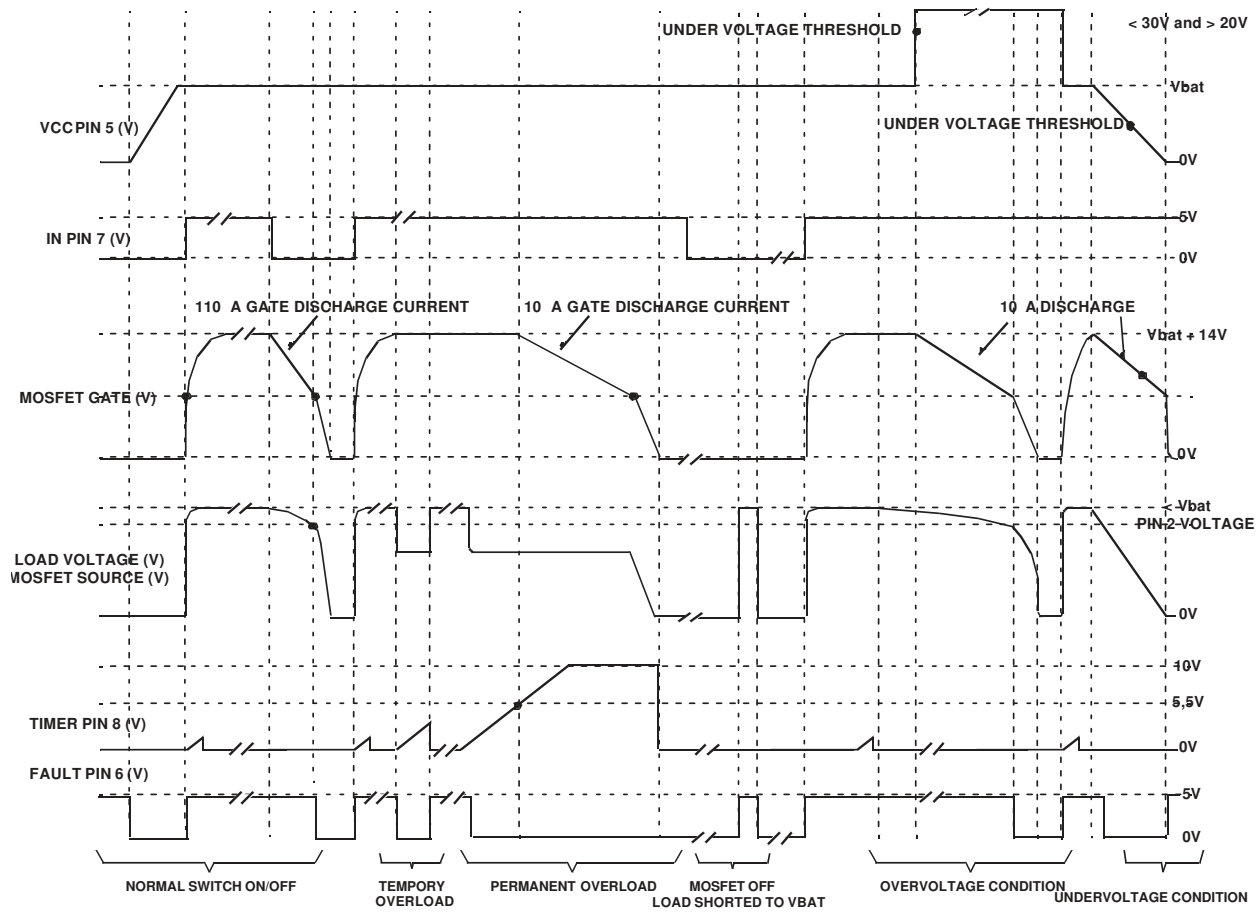
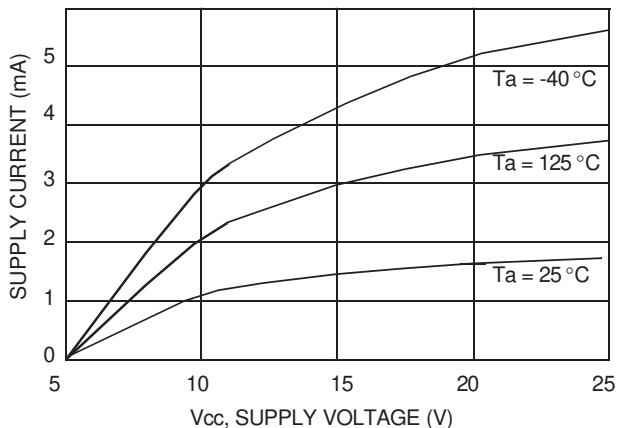

Figure 5. Descriptive Waveform Diagram



**ELECTRICAL PERFORMANCE CURVES**



**Figure 6. Supply Current versus Supply Voltage.  
Pin 7 = 0V**

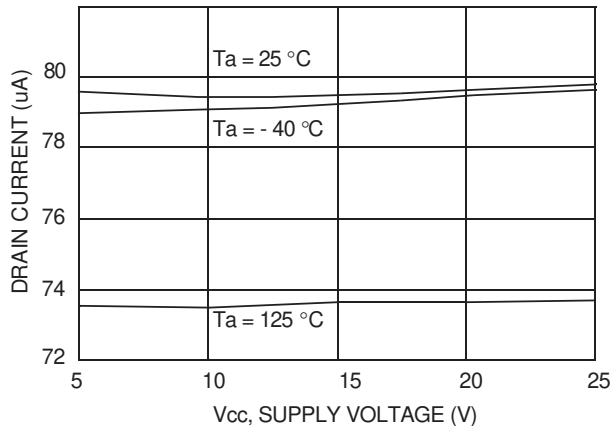

**Figure 9. Drain Current versus Supply Voltage**

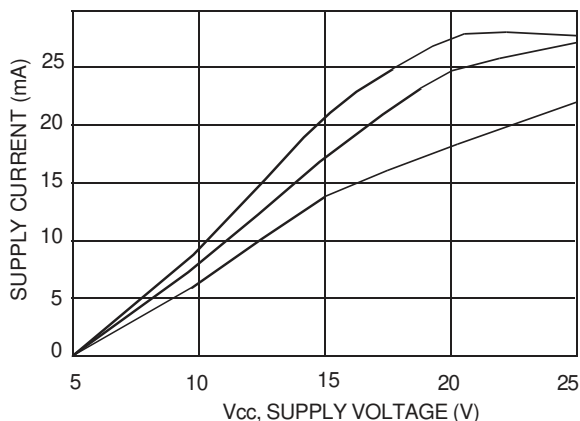

**Figure 7. Supply Current versus Supply Voltage.  
Pin 7 = 5.0V**

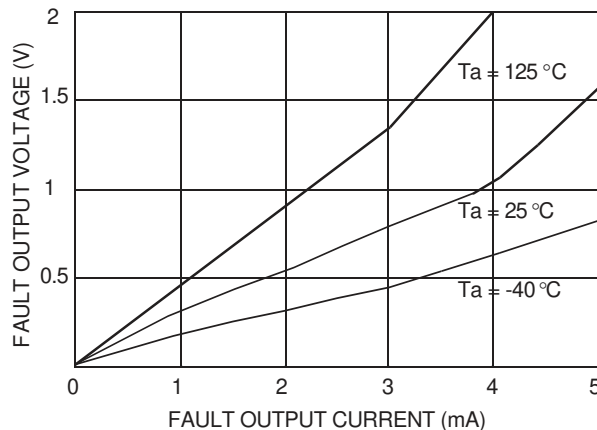

**Figure 10. Fault Output Voltage versus Current**

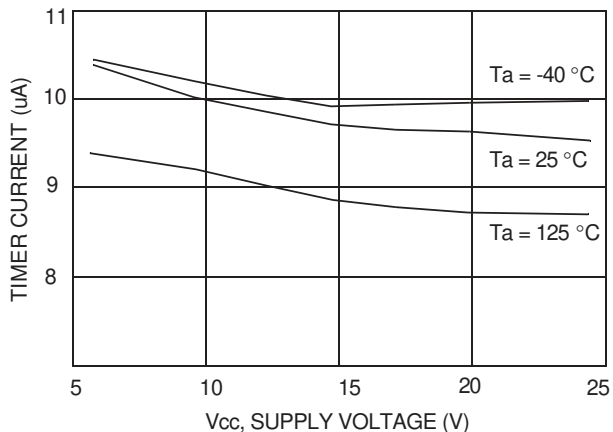

**Figure 8. Time Current versus Supply Voltage**

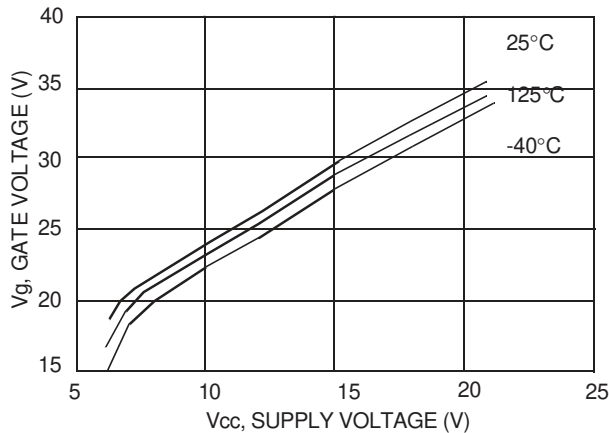

**Figure 11. Gate Voltage versus Voltage**

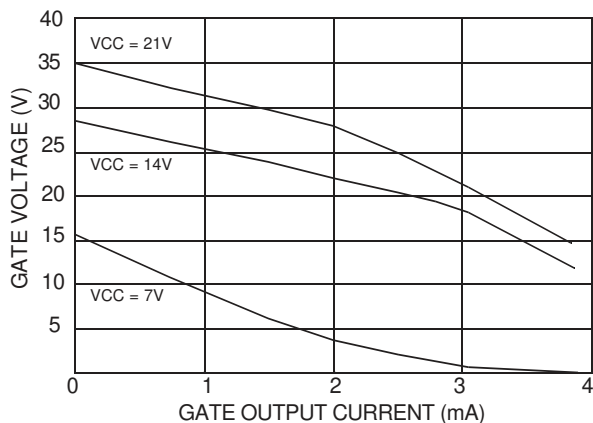

Figure 12. Gate Voltage versus Gate Output Current.  
 $T_A = 25^\circ\text{C}$ .

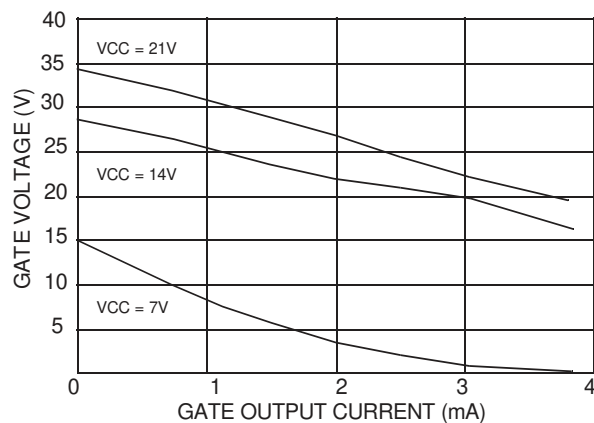

Figure 14. Gate Voltage versus Gate Output Current.  
 $T_A = 40^\circ\text{C}$ .

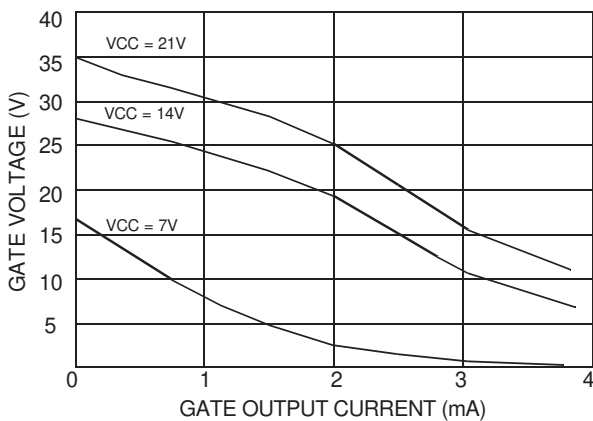

Figure 13. Gate Voltage versus Gate Output Current.  
 $T_A = 125^\circ\text{C}$ .

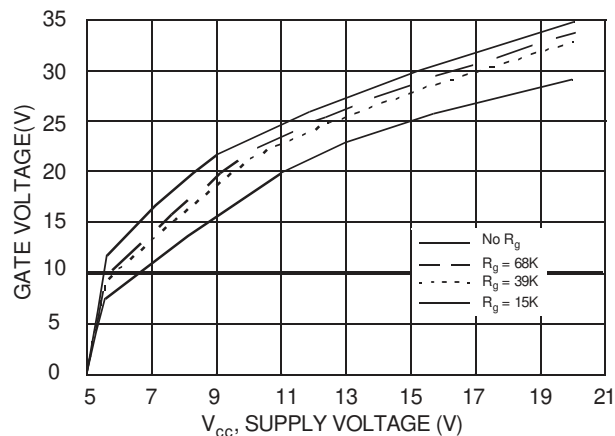

Figure 15. Gate Voltage versus  $V_{CC}$  and  $R_G$  at  
 $T_A = 25^\circ\text{C}$ .

## FUNCTIONAL DESCRIPTION

### INTRODUCTION

The MC33198 is a high side TMOS driver, dedicated to automotive applications. It is used in conjunction with an external power MOSFET for high side drive applications. The device can drive and protect a large variety of MOSFETs. The device has a CMOS compatible input control, charge pump to drive the MOSFET gate, and fault detection circuitry based on programmable  $V_{DS}$  monitoring to detect shorted loads. It also includes a programmable timer function to eliminate undesired switch off due to inrush currents, and a status pin which reports the output status of both on and off MOSFET states. The device uses few external components, and offers an economical solution to large current high side switches. It also has PWM capability up to 1kHz.

### POWER SUPPLY

The MC33198 can be supplied from the battery line. It is designed with a 60V technology, making it able to sustain up to 60V transient pulses. In the off state, with pin 7 low, the supply current can be up to 5.0mA, and in operation, pin 7 high, the current up to 25mA. The device has an undervoltage detection and shutdown near 7.0V. Below this value the MOSFET is turned off. There is also a 25V overvoltage detection which switches off the output pin 4 to protect both the MOSFET and the load when  $V_{CC}$  is higher than 25V.

### CHARGE PUMP

The device incorporates a self running charge pump with an internal capacitor and is connected at Gate pin 4. To prevent oscillation, a serial resistor can be added. The charge pump is able to charge a 25nF capacitor in less than 1ms. This allows the MC33198 to have a rapid response time and to drive the external TMOS gate very quickly, allowing fast switching on of the load. The device has an internal 15V zener diode between pin 4 and 1, to clamp the Gate-to-Source voltage and protect the MOSFET gate oxide from destruction. See [Dynamic Electrical Characteristics on page 7](#) for details.

### BAND GAP AND REFERENCE CURRENTS

The MC33198 has an internal band gap reference voltage which generates all the internal thresholds. This band gap is also used to generate internal reference currents necessary for proper operation of the device. These currents are :

Pin 2 : Drain current (typically 80mA).

Pin 4 : High and low gate discharge currents (typically 100mA and 10mA).

Pin 8 : Timer charge current (10mA typical).

All these currents are derived from the same reference voltage and internal resistor. Their accuracy and variability is approximately +25% over the full temperature and voltage range. In addition, a passive pull down current of 5.0mA

maintains the gate of the MOSFET below 0.9V when the device has no supply, ensuring that the MOSFET remains off. This passive pulldown current is operating even if device VCC (pin 5) is not powered up.

### INPUT CIRCUITRY

The Input pin (pin 7) of the device is CMOS compatible and can be directly connected to a microcontroller. The input current is determined by an internal pull down resistor, typically 36k $\Omega$ . A hysteresis of 0.8 V minimum is present at this input.

### OUTPUT STATUS

The device has a status output (pin 6) which has an open collector structure. This pin is used to report the MOSFET overload condition or the LOAD status when the MOSFET is off. The device Pin 1 (Source) is compared to a programmable threshold at Pin 2, in both the on and off state of the MOSFET. This allows the detection of the MOSFET over  $V_{DS}$  or over load conditions when the MOSFET is on and the load short to VBAT monitoring, when the MOSFET is in the off state. This status pin is normally connected to a pull-up resistor and a micro input, and can drive up to 1.0mA.

### TIMER

The Timer pin (pin 8) is used in conjunction with an external capacitor to create a delay between the overload detection and the shutdown of the MOSFET. In case of overload, the internal current source pin 8 will charge the capacitor. When the voltage at pin 8 reaches the 5.5V threshold, the internal C3 comparator will be triggered and switch off the output to protect the MOSFET. The fault and the MOSFET turn off condition are latched and are reset by switching the input off and on. The delay between the overload detection and actual MOSFET turn off is used to allow a temporary overload which will prevent the system from switching off during possible inrush currents or transients.

### MOSFET PROTECTION AND OUTPUT VOLTAGE MONITORING

The MC33198 has the ability to sense the output MOSFET source voltage and compare it to a predetermined threshold. This threshold is programmable, using the internal reference current of 80mA and an external resistor connected at pin 2 (DRN). The device can monitor the output load voltage, as well as protect the MOSFET in case of overload.

The overload detection threshold must be adapted to the MOSFET itself depending on the load to be driven and the thermal capability of the MOSFET. In practice, the maximum acceptable  $V_{DS}$  of the MOSFET should be determined and based upon the MOSFET maximum power dissipation.

In addition, the pin 8 capacitor value should be calculated to allow inrush current.

## SOURCE (PIN1) AND DRAIN (PIN2) FUNCTIONALITY

These two pins are used to sense the MOSFET and load conditions. Pin 2 is connected to the internal pull down current source of 80mA and to the C2 comparator. An external resistor connected between pin 2 and VBAT creates a voltage drop across this resistor. The voltage drop will be the MOSFET maximum acceptable drain to source voltage and the C2 comparator threshold.

Pin 1 is connected to the MOSFET source pin. Two different cases should be considered, MOSFET on or off :

When the MOSFET is on and working under normal conditions, the  $V_{DS}$  should be less than the voltage developed at pin 2. So, the C2 comparator output is low and the status is high. No current will flow through the pin 8 capacitor.

If the MOSFET encounters an overload or if the load is shorted to Gnd, the voltage at the source will cross the pin 2 voltage and go below this pin 2 voltage, thereby turning on the C2 comparator. The comparator will pull the status pin 6 low and will enable the charge of the pin 8 capacitor. When the voltage at the capacitor reaches 5.5V, the C3 comparator will switch off the MOSFET by disabling the charge pump and the 110mA current source. The MOSFET gate will be discharged only by the 10mA current source. The MOSFET is latched off and can be turned back on again by switching the input pin 7 to 0 and back to 1.

When the MOSFET is off, we have the same scheme. Under normal conditions, the load should pull the source voltage to Gnd, thus C2 comparator output is high and status pin pulled low. If the load is shorted to VBAT for instance, source pin will be higher than pin 2, The C2 output comparator is low and the status pin is high. This is summarized in [Table 5, Status Functionality](#).

**Table 5. Status Functionality**

INPUT PIN 7	CONDITION	LOAD SOURCE VOLTAGE	C2 OUTPUT COMP	STATUS PIN 6	TIMER PIN 8
Low	Normal	$<V_{PIN2}$	High	Low	Low
Low	Short Circuit to $V_{BAT}$	$>V_{PIN2}$	Low	High	Charge by 10 $\mu$ A source
High	Normal	$>V_{PIN2}$	Low	High	Low
High	Short to GND or Overload	$<V_{PIN2}$	High	Low	Charge by 10 $\mu$ A source

## OPERATION WITH INDUCTIVE LOADS

The device can drive the MOSFET during inductive loads switching applications. In this case, a 1.0kW resistor should be connected between source of the MOSFET and device pin 1. The resistor will limit the current flowing into pin 1 and prevent MC33198 from damage while switching the inductive load off. The gate voltage is internally clamped at  $-V_{be}$  (0.6V typical), and the  $V_{DS}$  is limited to  $V_{BAT} + V_{BE} + V_{GSON}$  to prevent excessive power dissipation in the MOSFET. The load voltage is limited to  $V_{BE} + V_{GSON}$  and allows a reasonable discharge current.

## SWITCHING ON

The MOSFET switching on is ensured by the internal charge pump. The charge pump response time versus the MOSFET gate capacitance is shown in [Table 4, Dynamic Electrical Characteristics](#).

## SWITCHING OFF

Here two cases have to be discussed: the MOSFET normally switching off, and the switching off under a fault condition. The normal switching off is done by internal pull down current sources. The value is 110mA and is in fact composed of two current sources in parallel: a 100mA and a 10mA source. The 10mA current is always connected to the gate pin 4 as shown in the [Internal Block Diagram on page 2](#).

The 100mA source can be disabled. This is the case when the MOSFET is switched off under fault conditions. The device will disable the 100mA current source and the MOSFET gate will be discharged only by a 10mA current. The time required to switch off the MOSFET will be much longer in this case, and will result in a lower overvoltage at the MOSFET, especially when the device drives high inductive loads.

## OFF STATE OPERATION WITHOUT VCC CONNECTION

When pin 7 is in the low state, the MOSFET is off. If  $V_{BAT}$  is present, the gate voltage is discharged by the 110mA current source. In the case of a  $V_{BAT}$  disconnection, a self sustaining 5.0mA pull down current source is incorporated in the device, to ensure that the MOSFET gate capacitor is discharged and tied below 0.9V. In case of a VCC disconnection, input pin 7 has no effect on the gate voltage, which is maintained below 0.9V. In this case, the status pin is high. Low leakage current at pin 2 (10mA max) allows the operation with the MOSFET and MC33198 pin 2 permanently connected to the battery.  $V_{CC}$  and other functions can be switched off from the main battery line. See [Figure 18](#).

## PWM OPERATION

Since the MC33198 charge pump can deliver a high current, the MOSFET gate can be charged fast enough to allow for PWM operations. The maximum PWM frequency is dependent on the MOSFET itself and mainly its gate to the source capacitor value. Depending on the PWM frequency,

the switch off time can be long, compared to the on-switching time response. This is due to the 110mA gate discharge current. To improve this parameter, a resistor can be added in parallel with the gate of the MOSFET. See [Figures 16](#) and [17](#).

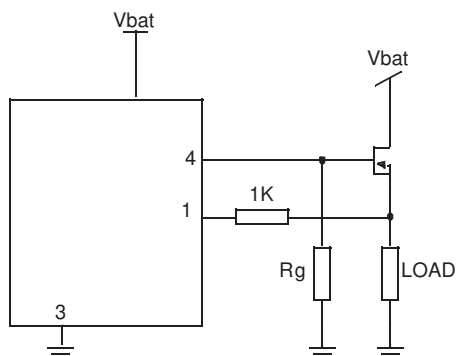

**Figure 16. Schematic with  $R_{GATE}$  Resistor**

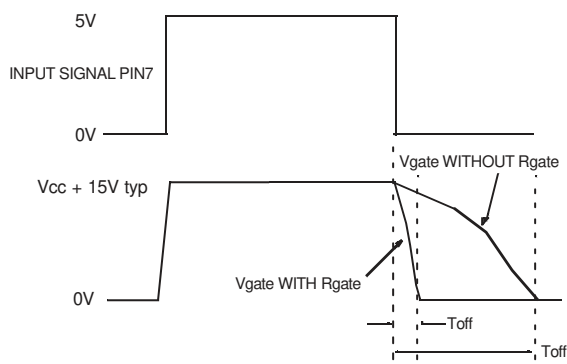

**Figure 17.  $R_{GATE}$  Signal Comparison**

This resistor will reduce (in some way) the charge pump output voltage available for the MOSFET, but the device will still provide enough Gate-to-Source voltage to maintain the MOSFET “on” in good conditions. The resistor will mainly act as an additional discharge current, which will reduce the switch off time of the overall application. See the [Table 6, Switching Off Characteristics with MOSFET Additional Gate Resistor](#) and [Figure 15](#), which show the pin 4 voltage depending on the additional gate resistor and the off switching time due to this resistor.

If a very low switching time is needed, the resistor has to be an extremely low value, resulting in low gate voltage not high enough to ensure proper MOSFET operation. In this case, a logic level MOSFET can be used. Logic levels will operate with  $V_{GS}$  of 5.0V, with the same performance as a standard MOSFET having a 12V  $V_{GS}$ . Care should be taken regarding the maximum gate to source voltage of a logic level MOSFET. An additional zener might be necessary to prevent gate oxide damage.

**Table 6. Switching Off Characteristics with MOSFET Additional Gate Resistor**

$R_{GATE}$ ( $R_G$ )	VCC (V)	$V_{GATE}$ (V)	$T_{OFF}$ ( $\mu$ sec)
No R	7.0	16	450
	10	23	700
	14	28	750
	20	34	780
68 k $\Omega$	7.0	14	160
	10	22	230
	14	27	230
	20	33	220
39 k $\Omega$	7.0	13	100
	10	21	160
	14	26	160
	20	32	150
15 k $\Omega$	7.0	11	30
	10	17.5	50
	14	24	50
	20	28.5	50

**Notes**

1. Time from negative edge of input signal (Pin 7) to negative edge of gate voltage (Pin 4) measured at 5V threshold.
2. Gate discharge time, not LOAD switching OFF time.L
3. TMOS used is Freescale MTP50N06, load 10 $\Omega$  resistor.

**REVERSE BATTERY**

The device does not sustain reverse battery operation for  $V_{CC}$  voltages greater than - 0.6V in magnitude. In application, pin 5 should be protected from reverse battery by connecting a diode in series with the VBAT line.

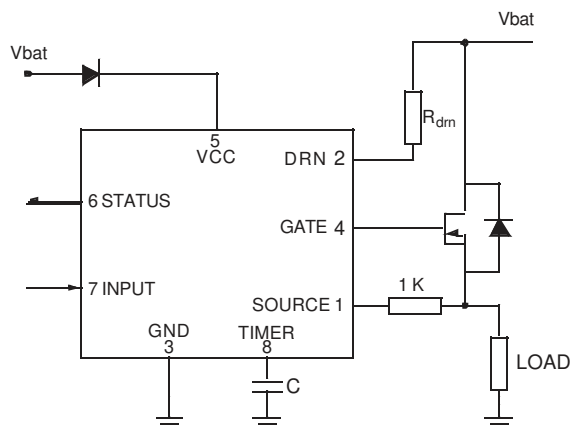
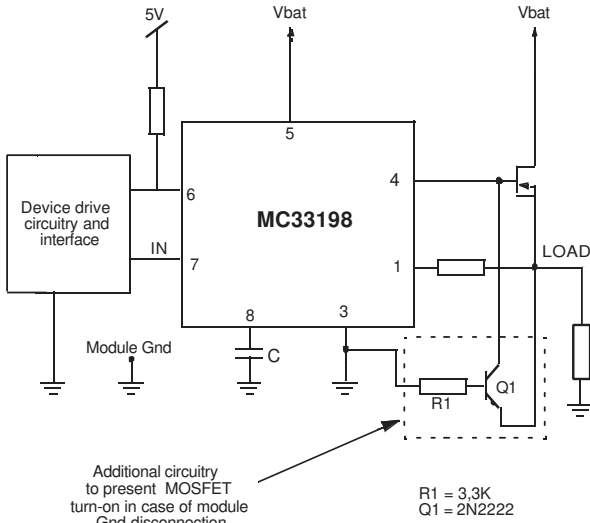

**Figure 18. 33198 Reverse Battery**

Pin 2, which is normally connected to a resistor, can sustain a reverse battery operation, providing that the DRN resistor is higher than 3.3K. A 1K resistor at pin 1 is also necessary to limit the reverse current flowing through the MOSFET body diode.

### OPERATION

When module GND is disconnected, and if the VBAT connection is still present, pin 3 of the MC33198 goes to about 2/3 of  $V_{BAT}$ , if additional circuitry is not inserted. With R1/Q1, the Gate/Source voltage of the MOSFET is shorted as soon as pin 3 voltage rises above GND level. See [Figure 19. 33198 GND Disconnection Circuitry](#)

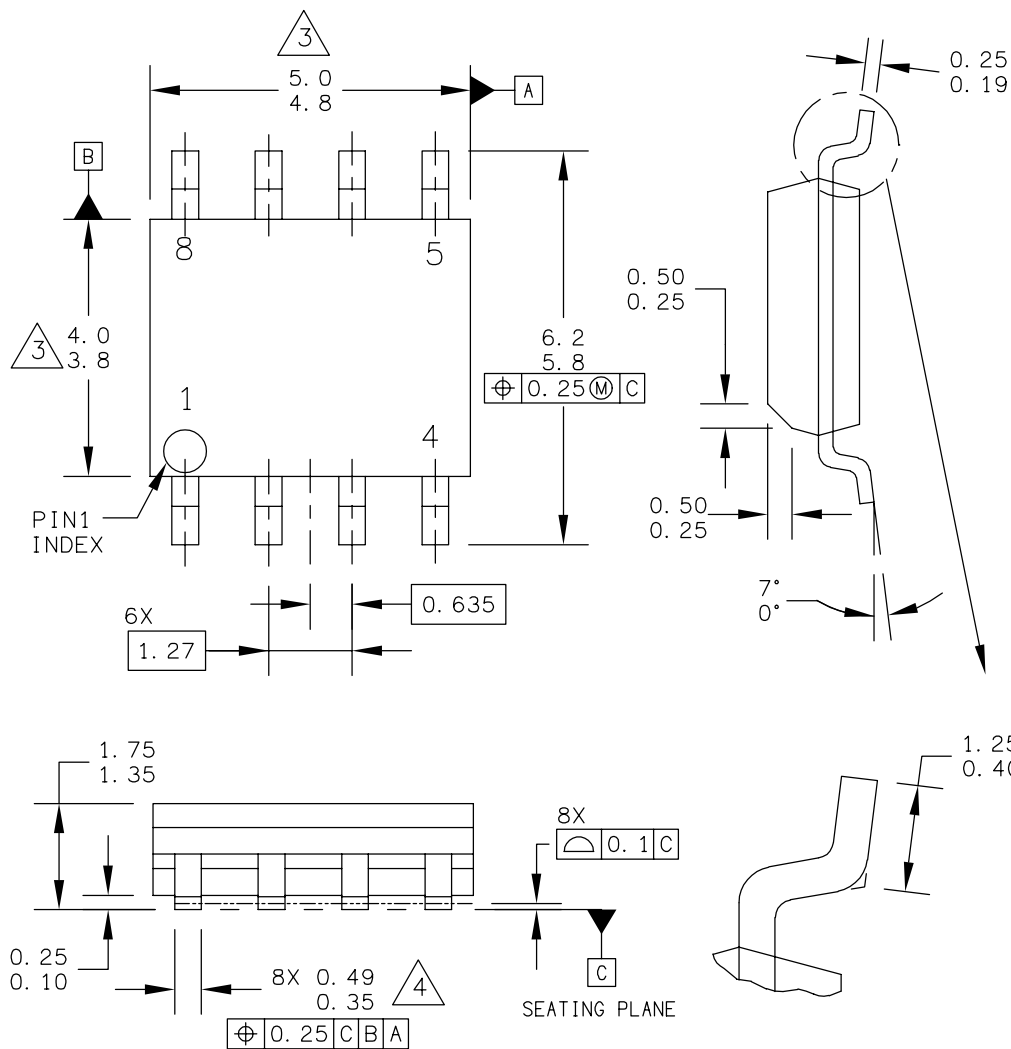

**Figure 19. 33198 GND Disconnection Circuitry**

# PACKAGING

## PACKAGE DIMENSIONS

For the most current package revision, visit [www.freescale.com](http://www.freescale.com) and perform a keyword search using the "98A" listed below.



© FREESCALE SEMICONDUCTOR, INC. ALL RIGHTS RESERVED.	<b>MECHANICAL OUTLINE</b>	PRINT VERSION NOT TO SCALE	
TITLE:  8LD SOIC NARROW BODY	DOCUMENT NO: 98ASB42564B	REV: U	
	CASE NUMBER: 751-07	07 APR 2005	
	STANDARD: JEDEC MS-012AA		

**D SUFFIX**  
**EF SUFFIX (PB-FREE)**  
8-PIN  
PLASTIC PACKAGE  
98ASB42564B  
ISSUE U

## REVISION HISTORY

REVISION	DATE	DESCRIPTION OF CHANGES
2.0	11/2006	<ul style="list-style-type: none"> <li>• Converted to Freescale format.</li> <li>• Implemented Revision History page.</li> <li>• Removed Comparison of the 33198 TO the 33091</li> <li>• Added part number MCZ33198EF (Pb-Free) to Ordering Information on page 1</li> <li>• Added <a href="#">Peak Package Reflow Temperature During Reflow <sup>(2)</sup>, <sup>(3)</sup></a> on page 4</li> </ul>



## How to Reach Us:

### Home Page:

[www.freescale.com](http://www.freescale.com)

### Web Support:

<http://www.freescale.com/support>

### USA/Europe or Locations Not Listed:

Freescale Semiconductor, Inc.  
 Technical Information Center, EL516  
 2100 East Elliot Road  
 Tempe, Arizona 85284  
 +1-800-521-6274 or +1-480-768-2130  
[www.freescale.com/support](http://www.freescale.com/support)

### Europe, Middle East, and Africa:

Freescale Halbleiter Deutschland GmbH  
 Technical Information Center  
 Schatzbogen 7  
 81829 Muenchen, Germany  
 +44 1296 380 456 (English)  
 +46 8 52200080 (English)  
 +49 89 92103 559 (German)  
 +33 1 69 35 48 48 (French)  
[www.freescale.com/support](http://www.freescale.com/support)

### Japan:

Freescale Semiconductor Japan Ltd.  
 Headquarters  
 ARCO Tower 15F  
 1-8-1, Shimo-Meguro, Meguro-ku,  
 Tokyo 153-0064  
 Japan  
 0120 191014 or +81 3 5437 9125  
[support.japan@freescale.com](mailto:support.japan@freescale.com)

### Asia/Pacific:

Freescale Semiconductor Hong Kong Ltd.  
 Technical Information Center  
 2 Dai King Street  
 Tai Po Industrial Estate  
 Tai Po, N.T., Hong Kong  
 +800 2666 8080  
[support.asia@freescale.com](mailto:support.asia@freescale.com)

### For Literature Requests Only:

Freescale Semiconductor Literature Distribution Center  
 P.O. Box 5405  
 Denver, Colorado 80217  
 1-800-441-2447 or 303-675-2140  
 Fax: 303-675-2150  
[LDCForFreescaleSemiconductor@hibbertgroup.com](mailto:LDCForFreescaleSemiconductor@hibbertgroup.com)

RoHS-compliant and/or Pb-free versions of Freescale products have the functionality and electrical characteristics of their non-RoHS-compliant and/or non-Pb-free counterparts. For further information, see <http://www.freescale.com> or contact your Freescale sales representative.

For information on Freescale's Environmental Products program, go to <http://www.freescale.com/epp>.

Information in this document is provided solely to enable system and software implementers to use Freescale Semiconductor products. There are no express or implied copyright licenses granted hereunder to design or fabricate any integrated circuits or integrated circuits based on the information in this document.

Freescale Semiconductor reserves the right to make changes without further notice to any products herein. Freescale Semiconductor makes no warranty, representation or guarantee regarding the suitability of its products for any particular purpose, nor does Freescale Semiconductor assume any liability arising out of the application or use of any product or circuit, and specifically disclaims any and all liability, including without limitation consequential or incidental damages. "Typical" parameters that may be provided in Freescale Semiconductor data sheets and/or specifications can and do vary in different applications and actual performance may vary over time. All operating parameters, including "Typicals", must be validated for each customer application by customer's technical experts. Freescale Semiconductor does not convey any license under its patent rights nor the rights of others. Freescale Semiconductor products are not designed, intended, or authorized for use as components in systems intended for surgical implant into the body, or other applications intended to support or sustain life, or for any other application in which the failure of the Freescale Semiconductor product could create a situation where personal injury or death may occur. Should Buyer purchase or use Freescale Semiconductor products for any such unintended or unauthorized application, Buyer shall indemnify and hold Freescale Semiconductor and its officers, employees, subsidiaries, affiliates, and distributors harmless against all claims, costs, damages, and expenses, and reasonable attorney fees arising out of, directly or indirectly, any claim of personal injury or death associated with such unintended or unauthorized use, even if such claim alleges that Freescale Semiconductor was negligent regarding the design or manufacture of the part.

Freescale™ and the Freescale logo are trademarks of Freescale Semiconductor, Inc. All other product or service names are the property of their respective owners.

© Freescale Semiconductor, Inc., 2007. All rights reserved.