

PRODUCT NUMBER

71979-YXXLF

RoHS COMPATIBLE, SEE NOTE 7

PLATING

2 = 0.76µm GOLD/GXT,
(PdNi WITH GOLD FLASH) ON CONTACT AREA
2µm MIN MATTE TIN

3 = 2µm TIN MIN FULL PLATED

UNDERPLATE : 1.27µm Ni MIN

| TOTAL NUMBER OF POSITIONS | |
|---------------------------|----|
| 06 | 26 |
| 08 | 34 |
| 10 | 40 |
| 14 | 44 |
| 16 | 50 |
| 18 | 60 |
| 20 | 64 |

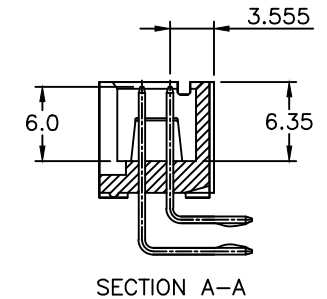
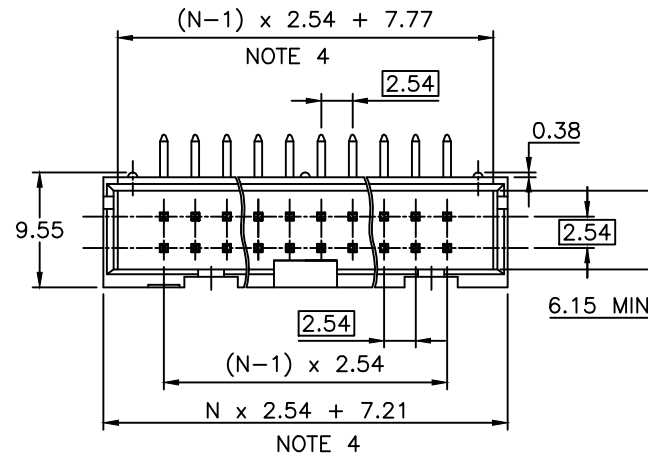

NOTES:

- HOUSING MAT'L : GLASS FILLED THERMOPLASTIC. UL94V-0 COLOR: BLUE
- PIN MATERIAL : PHOSPHOR BRONZE
- PRODUCT PACKAGED IN TUBES.
- TO DETERMINE DIMENSIONS :
N = NUMBER OF POSITIONS PER ROW
EXAMPLE : 8 POS N x 2.54 = 20.32mm
- NO LEFT POLARIZATION FOR POS 04, 06, 08, 14.
NO RIGHT POLARIZATION FOR POS 04, 06, 08.
- RETENTION LEGS IN THE CENTER OF THE CONNECTOR.
- RoHS COMPATIBLE PRODUCT SPECIFICATIONS

a - PLATING:

"LF" MEANS THE PRODUCT IS LEAD-FREE,
2µm MINIMUM MATTE TIN OVER 1.27µm
MINIMUM NICKEL UNDERPLATE.

b - MANUFACTURING PROCESS COMPATIBILITY

THE HOUSING WILL WITHSTAND EXPOSURE TO
260°C ±5°C SOLDER BATH TEMPERATURE FOR
5 SECONDS IN A WAVE SOLDER APPLICATION
WITH A 1.6mm MIN THICK CIRCUIT BOARD.

c - LABELLING:

MEETS PACKAGING SPECS AS PER GS-14-920

d - LEGAL STATEMENT: SEE GS-47-0004

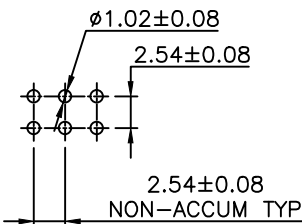
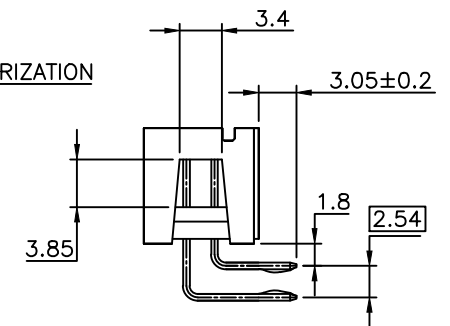
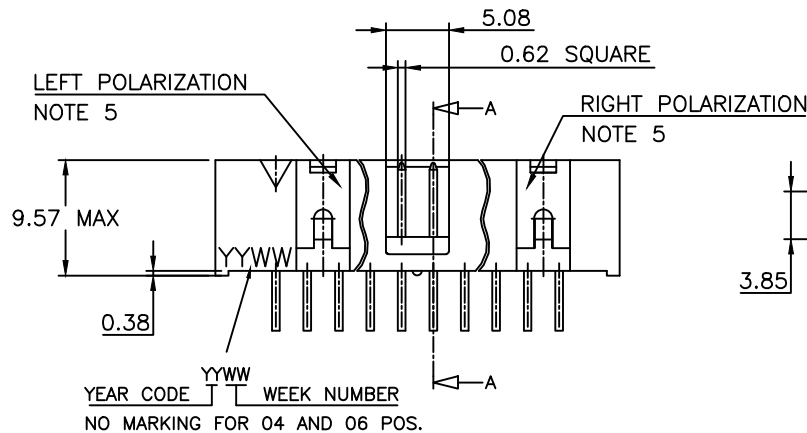

| mat'l. code | | surface | | tolerance | | projection | product family | |
|-------------|----------|----------|----------|---------------------------------------|-------------|------------|-------------------|--|
| SEE NOTES | | ISO 1302 | ISO 406 | ISO 1101 | ISO 1101 | mm | QUICKIE | |
| ltr | ecn no | dr | date | tolerances unless otherwise specified | | scale 1:1 | title | |
| J | F80621 | PNZ | 98.09.03 | angles | linear | | SHR.LP.HEADER | |
| K | F04-0388 | LMU | 04.12.22 | | | | RA.RETENTION LEGS | |
| L | F06-0229 | LMU | 06.07.18 | | | | dwg no | |
| M | F06-0314 | LMU | 06.11.02 | dr | L.MULIN | 04.12.20 | sheet 1 of 1 size | |
| N | F07-0198 | LMU | 07.05.30 | engr | J.COMPAGNON | 04.12.20 | 71979 A3 | |
| P | F08-0148 | YOV | 08.04.14 | chr | JCO | 04.12.22 | type | |
| R | B-19091 | LMU | 14.10.16 | appd | JCO | 04.12.22 | CUSTOMER Drawing | |
| sheet | revision | | | | | | | |
| index | sheet | | | | | | | |