

SPECIFICATION CONTROL DRAWING

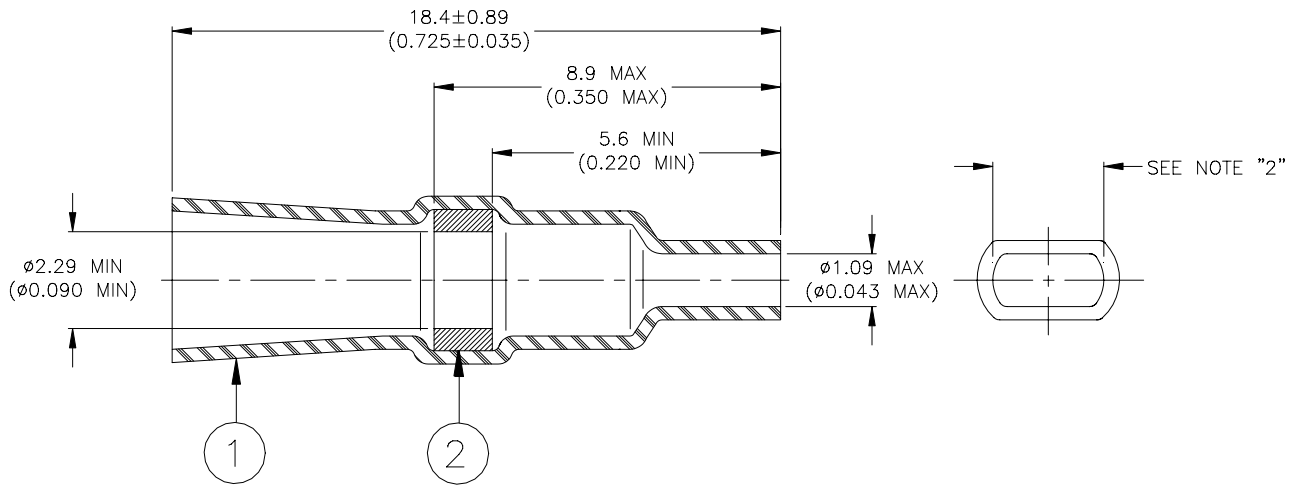

MATERIALS

1. INSULATION SLEEVE: Heat-shrinkable, transparent blue, radiation cross-linked modified polyvinylidene fluoride.
2. SOLDER PREFORM WITH FLUX:
 - SOLDER: TYPE Sn63 per ANSI J-STD-006.
 - FLUX: TYPE ROL 1 per ANSI-J-STD-004.
 - SOLDER WEIGHT: 8 milligrams minimum.

APPLICATION

1. This part is designed to connect a wire conforming to MIL-W-16878/1-B-22 to a pre-tinned 1.02 (0.040) diameter x 9.53 (0.375) high terminal pin.
2. Part will slip fit on an 1.02 (0.040) diameter pin.
3. Insulation will recover to an I.D. of 1.27 (0.050) maximum.

Raychem Interconnect <small>a division of tyco ELECTRONICS</small> 300 Constitution Drive Menlo Park, CA 94025, USA		THERMOFIT DEVICES	TITLE: SOLDERSLEEVE FOR 1.02 X 9.53 (.040 X .375) TERMINAL PIN – 22 AWG PVC INSULATED WIRE				
UNLESS OTHERWISE SPECIFIED DIMENSIONS ARE IN MILLIMETERS. INCHES DIMENSIONS ARE BETWEEN BRACKETS.			DOCUMENT NO.: D-129-15				
TOLERANCES: 0.00 N/A 0.0 N/A 0 N/A	ANGLES: N/A ROUGHNESS IN MICRON	Raychem reserves the right to amend this drawing at any time. Users should evaluate the suitability of the product for their application.	DCR NUMBER: D000579	REPLACES: D990741			
DRAWN BY: M. FORONDA	DATE: 27-Sept-00	PROD. REV. G	DOC ISSUE: 2	SCALE: None	SIZE: A	SHEET: 1 of 1	

If this document is printed it becomes uncontrolled. Check for the latest revision.