



Please note that Cypress is an Infineon Technologies Company.

The document following this cover page is marked as “Cypress” document as this is the company that originally developed the product. Please note that Infineon will continue to offer the product to new and existing customers as part of the Infineon product portfolio.

Continuity of document content

The fact that Infineon offers the following product as part of the Infineon product portfolio does not lead to any changes to this document. Future revisions will occur when appropriate, and any changes will be set out on the document history page.

Continuity of ordering part numbers

Infineon continues to support existing part numbers. Please continue to use the ordering part numbers listed in the datasheet for ordering.

Features

- Very high speed: 45 ns
- Wide voltage range: 2.20 V to 3.60 V
- Pin compatible with CY62136CV30
- Ultra low standby power
 - Typical standby current: 1 μ A
 - Maximum standby current: 7 μ A
- Ultra low active power
 - Typical active current: 2 mA at f = 1 MHz
- Easy memory expansion with \overline{CE} and \overline{OE} features
- Automatic power down when deselected
- Complementary metal oxide semiconductor (CMOS) for optimum speed/power
- Offered in a Pb-free 48-ball very fine ball grid array (VFBGA) and 44-pin thin small outline package (TSOP II) packages

Functional Description

The CY62136EV30 is a high performance CMOS static RAM organized as 128K words by 16 bits. This device features advanced circuit design to provide ultra low active current. This is ideal for providing More Battery Life™ (MoBL®) in portable applications such as cellular telephones. The device also has an automatic power down feature that significantly reduces power consumption when addresses are not toggling. The device can also be put into standby mode reducing power consumption by more than 99% when deselected (\overline{CE} HIGH). The input/output pins (I/O_0 through I/O_{15}) are placed in a high impedance state when: deselected (\overline{CE} HIGH), outputs are disabled (\overline{OE} HIGH), both Byte High Enable and Byte Low Enable are disabled (\overline{BHE} , BLE HIGH), or during a write operation (\overline{CE} LOW and WE LOW).

Writing to the device is accomplished by taking Chip Enable (\overline{CE}) and Write Enable (WE) inputs LOW. If Byte Low Enable (BLE) is LOW, then data from I/O pins (I/O_0 through I/O_7), is written into the location specified on the address pins (A_0 through A_{16}). If Byte High Enable (\overline{BHE}) is LOW, then data from I/O pins (I/O_8 through I/O_{15}) is written into the location specified on the address pins (A_0 through A_{16}).

Reading from the device is accomplished by taking Chip Enable (\overline{CE}) and Output Enable (\overline{OE}) LOW while forcing the Write Enable (WE) HIGH. If Byte Low Enable (BLE) is LOW, then data from the memory location specified by the address pins appear on I/O_0 to I/O_7 . If Byte High Enable (\overline{BHE}) is LOW, then data from memory appear on I/O_8 to I/O_{15} . See the Truth Table on page 11 for a complete description of read and write modes.

For a complete list of related documentation, [click here](#).

Logic Block Diagram

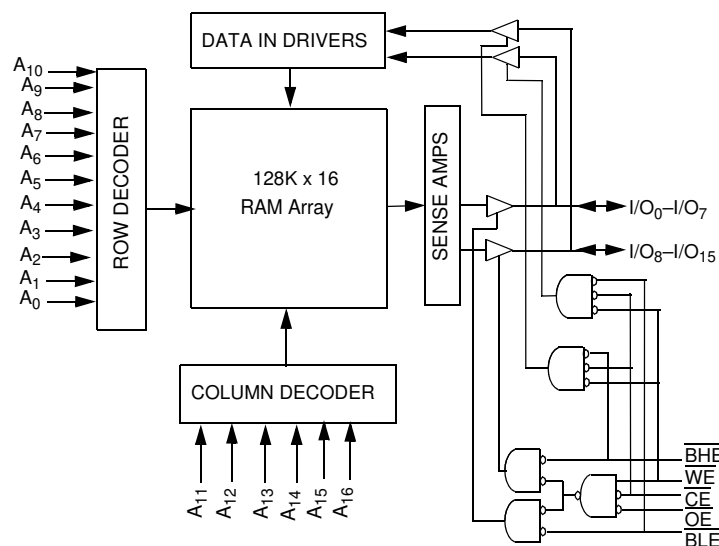

Contents

Pin Configurations	3	Ordering Information	12
Product Portfolio	3	Ordering Code Definitions	12
Maximum Ratings	4	Package Diagrams	13
Operating Range	4	Acronyms	15
Electrical Characteristics	4	Document Conventions	15
Capacitance	5	Units of Measure	15
Thermal Resistance	5	Document History Page	16
AC Test Loads and Waveforms	5	Sales, Solutions, and Legal Information	18
Data Retention Characteristics	6	Worldwide Sales and Design Support	18
Data Retention Waveform	6	Products	18
Switching Characteristics	7	PSoC® Solutions	18
Switching Waveforms	8	Cypress Developer Community	18
Truth Table	11	Technical Support	18

Pin Configurations

Figure 1. 48-ball VFBGA pinout (Top View) [1, 2]

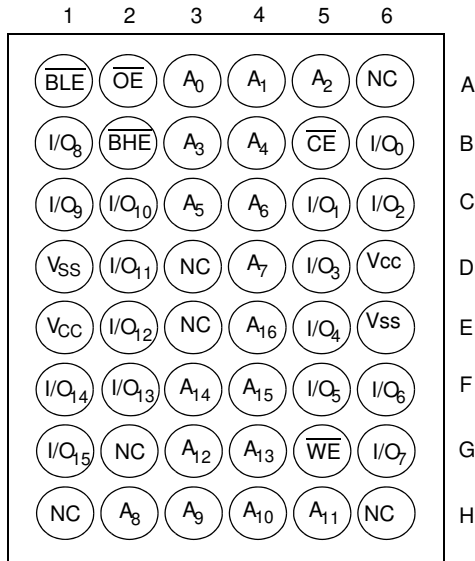
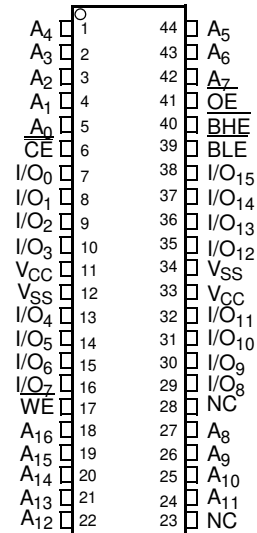

Figure 2. 44-pin TSOP II pinout (Top View) [1]



Product Portfolio

Product [3]	V _{CC} Range (V)			Speed (ns)	Power Dissipation					
					Operating ICC (mA)				Standby I _{SB2} (μA)	
	f = 1 MHz		f = f _{max}							
	Min	Typ [3]	Max		Typ [3]	Max	Typ [3]	Max	Typ [3]	Max
CY62136EV30LL	2.2	3.0	3.6	45	2	2.5	15	20	1	7

Notes

1. NC pins are not connected on the die.
2. Pins D3, H1, G2, H6 and H3 in the VFBGA package are address expansion pins for 4 Mb, 8 Mb, 16 Mb, and 32 Mb and 64 Mb respectively.
3. Typical values are included for reference only and are not guaranteed or tested. Typical values are measured at V_{CC} = V_{CC(typ)}, T_A = 25 °C.

Maximum Ratings

Exceeding the maximum ratings may impair the useful life of the device. These user guidelines are not tested.

Storage temperature -65 °C to + 150 °C

Ambient temperature with power applied -55 °C to + 125 °C

Supply voltage to ground potential [4, 5] ... -0.3 V to 3.9 V ($V_{CC\ MAX} + 0.3\ V$)

DC voltage applied to outputs in High Z state [4, 5] -0.3 V to 3.9 V ($V_{CC\ MAX} + 0.3\ V$)

DC input voltage [4, 5] -0.3 V to 3.9 V ($V_{CC\ MAX} + 0.3\ V$)

Output current into outputs (LOW) 20 mA

Static discharge voltage (per MIL-STD-883, Method 3015) > 2001 V

Latch-up current > 200 mA

Operating Range

Device	Range	Ambient Temperature	V_{CC} [6]
CY62136EV30LL	Industrial	-40 °C to +85 °C	2.2 V–3.6 V

Electrical Characteristics

Over the Operating Range

Parameter	Description	Test Conditions	45 ns			Unit
			Min	Typ [7]	Max	
V_{OH}	Output HIGH voltage	$I_{OH} = -0.1\ mA$, $V_{CC} = 2.20\ V$	2.0	–	–	V
		$I_{OH} = -1.0\ mA$, $V_{CC} = 2.70\ V$	2.4	–	–	V
V_{OL}	Output LOW voltage	$I_{OL} = 0.1\ mA$, $V_{CC} = 2.20\ V$	–	–	0.4	V
		$I_{OL} = 2.1\ mA$, $V_{CC} = 2.70\ V$	–	–	0.4	V
V_{IH}	Input HIGH voltage	$V_{CC} = 2.2\ V$ to $2.7\ V$	1.8	–	$V_{CC} + 0.3$	V
		$V_{CC} = 2.7\ V$ to $3.6\ V$	2.2	–	$V_{CC} + 0.3$	V
V_{IL}	Input LOW voltage	$V_{CC} = 2.2\ V$ to $2.7\ V$	-0.3	–	0.6	V
		$V_{CC} = 2.7\ V$ to $3.6\ V$	-0.3	–	0.8	V
I_{IX}	Input leakage current	$GND \leq V_I \leq V_{CC}$	-1	–	+1	μA
I_{OZ}	Output leakage current	$GND \leq V_O \leq V_{CC}$, output disabled	-1	–	+1	μA
I_{CC}	V_{CC} operating supply current	$f = f_{max} = 1/t_{RC}$, $V_{CC} = V_{CCmax}$, $I_{OUT} = 0\ mA$, CMOS levels	–	15	20	mA
		$f = 1\ MHz$	–	2	2.5	
I_{SB1} [8]	Automatic CE power-down current – CMOS inputs	$\overline{CE} \geq V_{CC} - 0.2\ V$, $V_{IN} \geq V_{CC} - 0.2\ V$, $V_{IN} \leq 0.2\ V$, $f = f_{max}$ (address and data only), $f = 0$ (\overline{OE} , and \overline{WE}), $V_{CC} = 3.60\ V$	–	1	7	μA
I_{SB2} [8]	Automatic CE power-down current – CMOS inputs	$\overline{CE} \geq V_{CC} - 0.2\ V$, $V_{IN} \geq V_{CC} - 0.2\ V$ or $V_{IN} \leq 0.2\ V$, $f = 0$, $V_{CC} = 3.60\ V$	–	1	7	μA

Notes

- $V_{L(min)}$ = -2.0 V for pulse durations less than 20 ns.
- $V_{H(max)}$ = $V_{CC} + 0.75\ V$ for pulse durations less than 20 ns.
- Full Device AC operation assumes a 100 μs ramp time from 0 to $V_{CC(min)}$ and 200 μs wait time after V_{CC} stabilization.
- Typical values are included for reference only and are not guaranteed or tested. Typical values are measured at $V_{CC} = V_{CC(typ)}$, $T_A = 25\ ^\circ C$.
- Chip enable (\overline{CE}) and byte enables (BHE and BLE) need to be tied to CMOS levels to meet the $I_{SB1}/I_{SB2}/I_{CCDR}$ specification. Other inputs can be left floating.

Capacitance

Parameter ^[9]	Description	Test Conditions	Max	Unit
C _{IN}	Input capacitance	T _A = 25 °C, f = 1 MHz, V _{CC} = V _{CC(typ)}	10	pF
C _{OUT}	Output capacitance		10	pF

Thermal Resistance

Parameter ^[9]	Description	Test Conditions	48-ball VFBGA	44-pin TSOP II	Unit
Θ _{JA}	Thermal resistance (junction to ambient)	Still air, soldered on a 3 × 4.5 inch, four-layer printed circuit board	54	57	°C/W
Θ _{JC}	Thermal resistance (junction to case)		12	17	°C/W

AC Test Loads and Waveforms

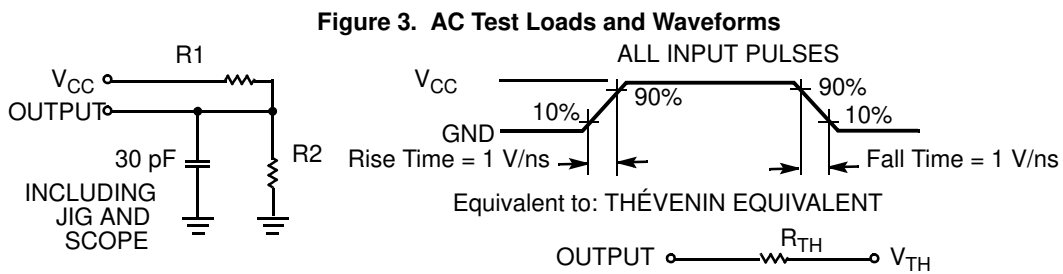

Parameters	2.50 V	3.0 V	Unit
R1	16667	1103	Ω
R2	15385	1554	Ω
R _{TH}	8000	645	Ω
V _{TH}	1.20	1.75	V

Note

9. Tested initially and after any design or process changes that may affect these parameters.

Data Retention Characteristics

Over the Operating Range

Parameter	Description	Conditions	Min	Typ ^[10]	Max	Unit
V_{DR}	V_{CC} for data retention		1.0	–	–	V
$I_{CCDR}^{[11]}$	Data retention current	$V_{CC} = 1.0\text{ V}$, $\overline{CE} \geq V_{CC} - 0.2\text{ V}$, $V_{IN} \geq V_{CC} - 0.2\text{ V}$ or $V_{IN} \leq 0.2\text{ V}$	–	0.8	3	μA
$t_{CDR}^{[12]}$	Chip deselect to data retention time		0	–	–	ns
$t_R^{[13]}$	Operation recovery time		45	–	–	ns

Data Retention Waveform

Figure 4. Data Retention Waveform^[14]

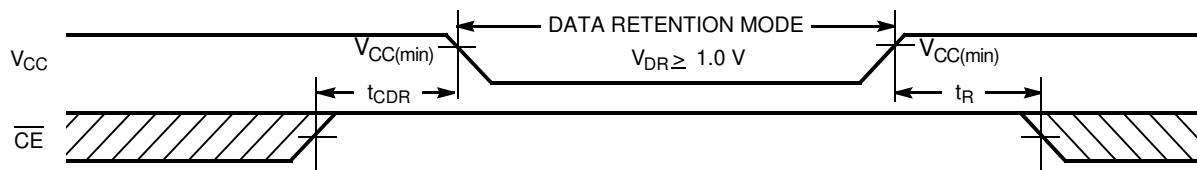

Notes

10. Typical values are included for reference only and are not guaranteed or tested. Typical values are measured at $V_{CC} = V_{CC(typ)}$, $T_A = 25\text{ }^\circ\text{C}$.

11. Chip enable (\overline{CE}) and byte enables (\overline{BHE} and \overline{BLE}) need to be tied to CMOS levels to meet the I_{SB1} / I_{SB2} / I_{CCDR} specification. Other inputs can be left floating.

12. Tested initially and after any design or process changes that may affect these parameters.

13. Full device operation requires linear V_{CC} ramp from V_{DR} to $V_{CC(min.)} \geq 100\text{ }\mu\text{s}$ or stable at $V_{CC(min.)} \geq 100\text{ }\mu\text{s}$.

14. $\overline{BHE}.\overline{BLE}$ is the AND of both \overline{BHE} and \overline{BLE} . The chip can be deselected by either disabling the chip enable signals or by disabling both \overline{BHE} and \overline{BLE} .

Switching Characteristics

Over the Operating Range

Parameter [15, 16]	Description	45 ns		Unit
		Min	Max	
Read Cycle				
t_{RC}	Read cycle time	45	–	ns
t_{AA}	Address to data valid	–	45	ns
t_{OHA}	Data hold from address change	10	–	ns
t_{ACE}	\overline{CE} LOW to data valid	–	45	ns
t_{DOE}	\overline{OE} LOW to data valid	–	22	ns
t_{LZOE}	\overline{OE} LOW to Low Z [17]	5	–	ns
t_{HZOE}	\overline{OE} HIGH to High Z [17, 18]	–	18	ns
t_{LZCE}	\overline{CE} LOW to Low Z [17]	10	–	ns
t_{HZCE}	\overline{CE} HIGH to High Z [17, 18]	–	18	ns
t_{PU}	\overline{CE} LOW to power-up	0	–	ns
t_{PD}	\overline{CE} HIGH to power-down	–	45	ns
t_{DBE}	$\overline{BLE}/\overline{BHE}$ LOW to data valid	–	22	ns
t_{LZBE}	$\overline{BLE}/\overline{BHE}$ LOW to Low Z [17]	5	–	ns
t_{HZBE}	$\overline{BLE}/\overline{BHE}$ HIGH to High Z [17, 18]	–	18	ns
Write Cycle [19, 20]				
t_{WC}	Write cycle time	45	–	ns
t_{SCE}	\overline{CE} LOW to write end	35	–	ns
t_{AW}	Address setup to write end	35	–	ns
t_{HA}	Address hold from write end	0	–	ns
t_{SA}	Address setup to write start	0	–	ns
t_{PWE}	\overline{WE} pulse width	35	–	ns
t_{BW}	$\overline{BLE}/\overline{BHE}$ LOW to write end	35	–	ns
t_{SD}	Data setup to write end	25	–	ns
t_{HD}	Data hold from write end	0	–	ns
t_{HZWE}	\overline{WE} LOW to High Z [17, 18]	–	18	ns
t_{LZWE}	\overline{WE} HIGH to Low Z [17]	10	–	ns

Notes

- Test conditions for all parameters other than tri-state parameters assume signal transition time of 3 ns (1 V/ns) or less, timing reference levels of $V_{CC(typ)}/2$, input pulse levels of 0 to $V_{CC(typ)}$, and output loading of the specified I_{OL}/I_{OH} as shown in Figure 3 on page 5.
- In an earlier revision of this device, under a specific application condition, READ and WRITE operations were limited to switching of the byte enable and/or chip enable signals as described in the Application Notes AN13842 and AN66311. However, the issue has been fixed and in production now, and hence, these Application Notes are no longer applicable. They are available for download on our website as they contain information on the date code of the parts, beyond which the fix has been in production.
- At any given temperature and voltage condition, t_{HZCE} is less than t_{LZCE} , t_{HZBE} is less than t_{LZBE} , t_{HZOE} is less than t_{LZOE} , and t_{HZWE} is less than t_{LZWE} for any given device.
- t_{HZOE} , t_{HZCE} , t_{HZBE} , and t_{HZWE} transitions are measured when the outputs enter a high impedance state.
- The internal write time of the memory is defined by the overlap of \overline{WE} , $\overline{CE} = V_{IL}$, \overline{BHE} and $\overline{BLE} = V_{IL}$. All signals must be ACTIVE to initiate a write and any of these signals can terminate a write by going INACTIVE. The data input setup and hold timing should be referenced to the edge of the signal that terminates the write.
- The minimum write pulse for Write Cycle No. 3 (\overline{WE} Controlled and \overline{OE} LOW) should be sum of t_{HZWE} and t_{SD} .

Switching Waveforms

Figure 5. Read Cycle 1: Address Transition Controlled [21, 22]

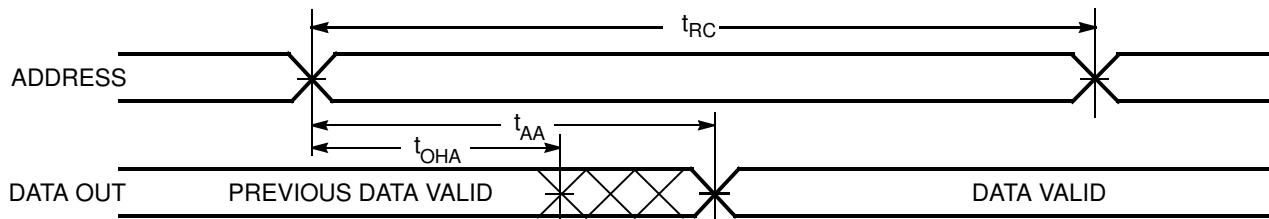
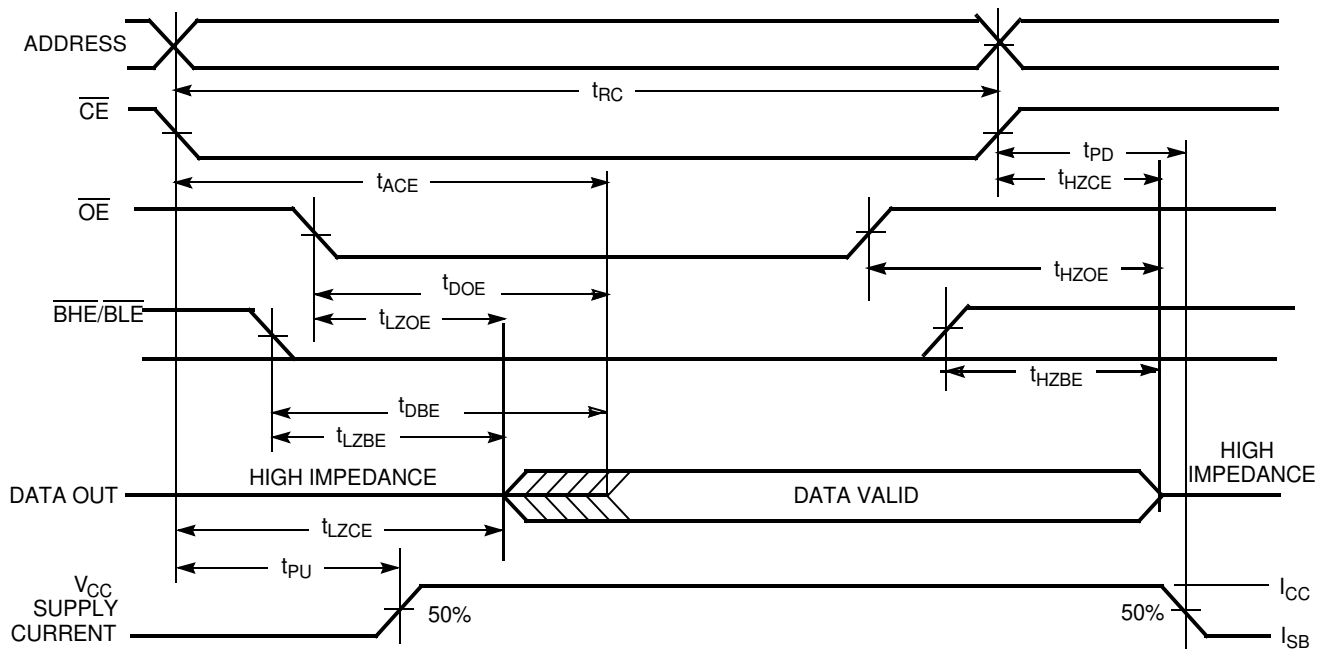

Figure 6. Read Cycle No. 2: \overline{OE} Controlled [22, 23]



Notes

21. The device is continuously selected. \overline{OE} , $\overline{CE} = V_{IL}$, \overline{BHE} and/or $\overline{BLE} = V_{IL}$.

22. \overline{WE} is HIGH for read cycle.

23. Address valid prior to or coincident with \overline{CE} and \overline{BHE} , \overline{BLE} transition LOW.

Switching Waveforms (continued)

Figure 7. Write Cycle No. 1: \overline{WE} Controlled [24, 25, 26]

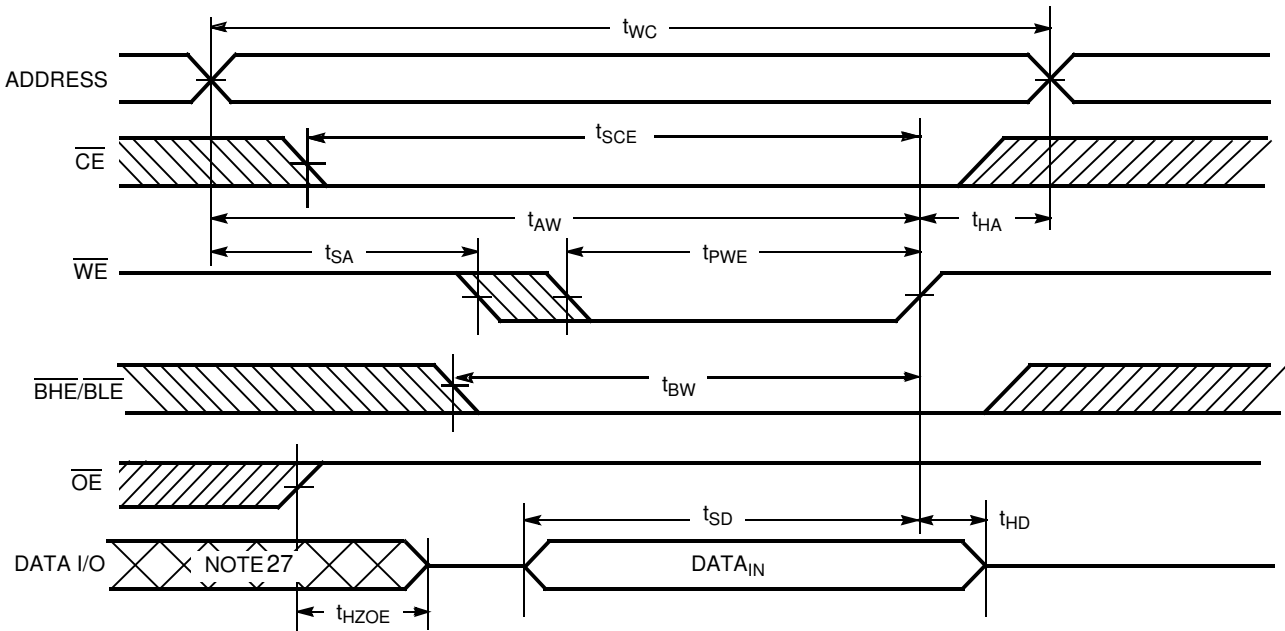
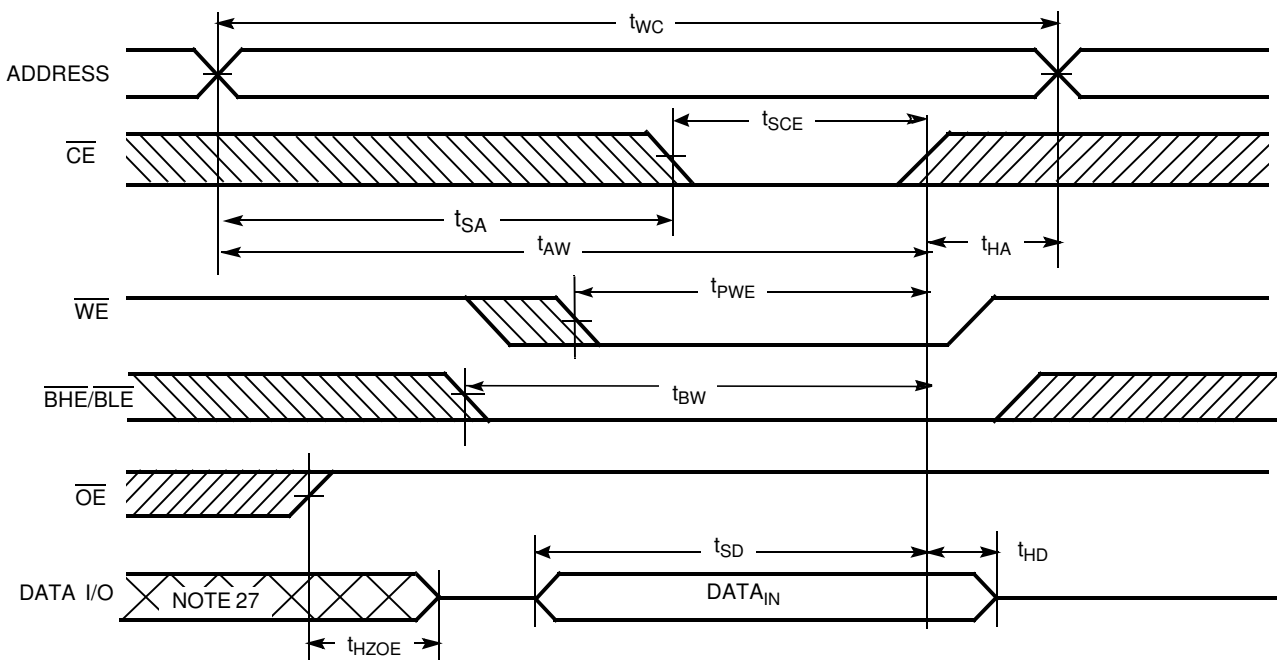

Figure 8. Write Cycle No. 2: \overline{CE} Controlled [24, 25, 26]



Notes

24. The internal write time of the memory is defined by the overlap of \overline{WE} , $\overline{CE} = V_{IL}$, \overline{BHE} and $\overline{BLE} = V_{IL}$. All signals must be ACTIVE to initiate a write and any of these signals can terminate a write by going INACTIVE. The data input setup and hold timing should be referenced to the edge of the signal that terminates the write.

25. Data I/O is high impedance if $\overline{OE} = V_{IH}$.

26. If \overline{CE} goes HIGH simultaneously with $\overline{WE} = V_{IH}$, the output remains in a high impedance state.

27. During this period, the I/Os are in output state and input signals should not be applied.

Switching Waveforms (continued)

Figure 9. Write Cycle No. 3: \overline{WE} Controlled, \overline{OE} LOW [28, 29]

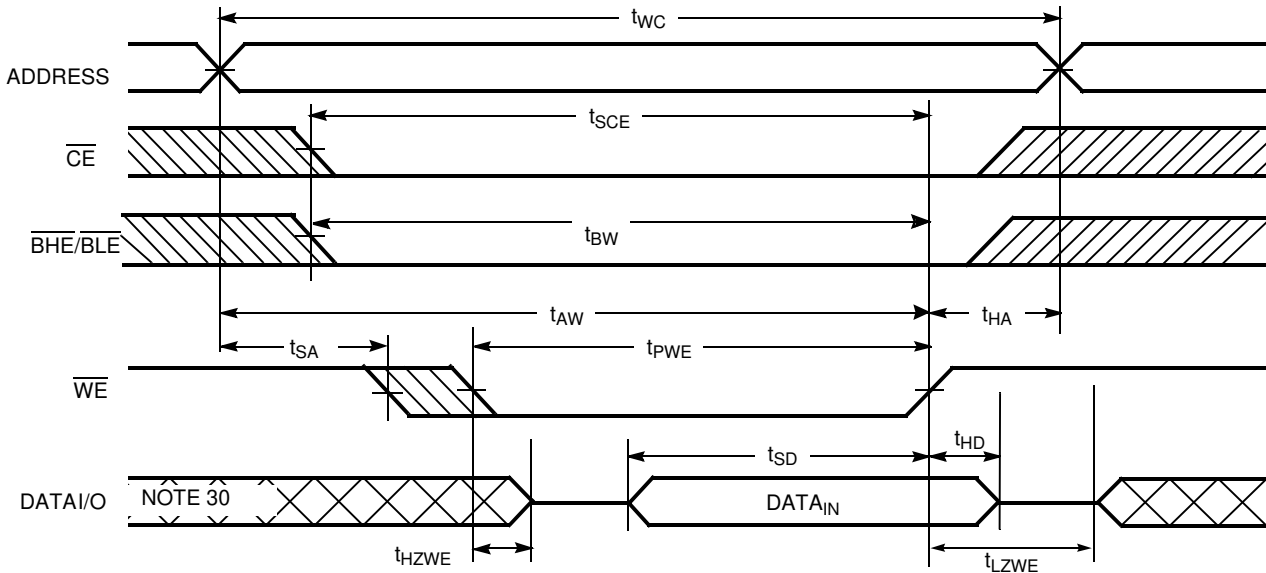
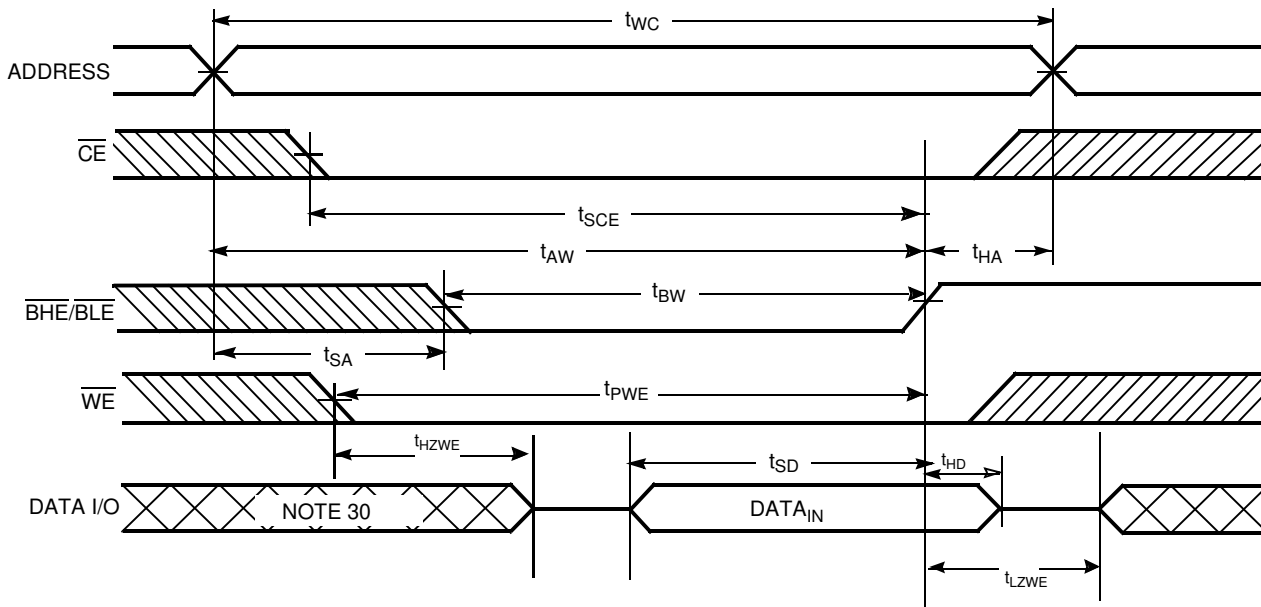

Figure 10. Write Cycle No. 4: $\overline{BHE}/\overline{BLE}$ Controlled, \overline{OE} LOW [28]



Notes

- 28. If \overline{CE} goes HIGH simultaneously with $\overline{WE} = V_{IH}$, the output remains in a high impedance state.
- 29. The minimum write cycle pulse width should be equal to the sum of t_{HZWE} and t_{SD} .
- 30. During this period, the I/Os are in output state and input signals should not be applied.

Truth Table

\overline{CE}	\overline{WE}	\overline{OE}	\overline{BHE}	\overline{BLE}	Inputs/Outputs	Mode	Power
H ^[31]	X	X	X ^[31]	X ^[31]	High Z	Deselect/power-down	Standby (I_{SB})
L	X	X	H	H	High Z	Output disabled	Active (I_{CC})
L	H	L	L	L	Data out (I/O_0 – I/O_{15})	Read	Active (I_{CC})
L	H	L	H	L	Data out (I/O_0 – I/O_7); I/O_8 – I/O_{15} in High Z	Read	Active (I_{CC})
L	H	L	L	H	Data Out (I/O_8 – I/O_{15}); I/O_0 – I/O_7 in High Z	Read	Active (I_{CC})
L	H	H	L	L	High Z	Output disabled	Active (I_{CC})
L	H	H	H	L	High Z	Output disabled	Active (I_{CC})
L	H	H	L	H	High Z	Output disabled	Active (I_{CC})
L	L	X	L	L	Data in (I/O_0 – I/O_{15})	Write	Active (I_{CC})
L	L	X	H	L	Data in (I/O_0 – I/O_7); I/O_8 – I/O_{15} in High Z	Write	Active (I_{CC})
L	L	X	L	H	Data in (I/O_8 – I/O_{15}); I/O_0 – I/O_7 in High Z	Write	Active (I_{CC})

Note

31. Chip enable (\overline{CE}) and Byte enables (\overline{BHE} and \overline{BLE}) must be at fixed CMOS levels (not floating). Intermediate voltage levels on these pins is not permitted.

Ordering Information

Speed (ns)	Ordering Code	Package Diagram	Package Type	Operating Range
45	CY62136EV30LL-45BVXI	51-85150	48-ball VFBGA (Pb-free)	Industrial
	CY62136EV30LL-45ZSXI	51-85087	44-pin TSOP II (Pb-free)	

Contact your local Cypress sales representative for availability of other parts

Ordering Code Definitions

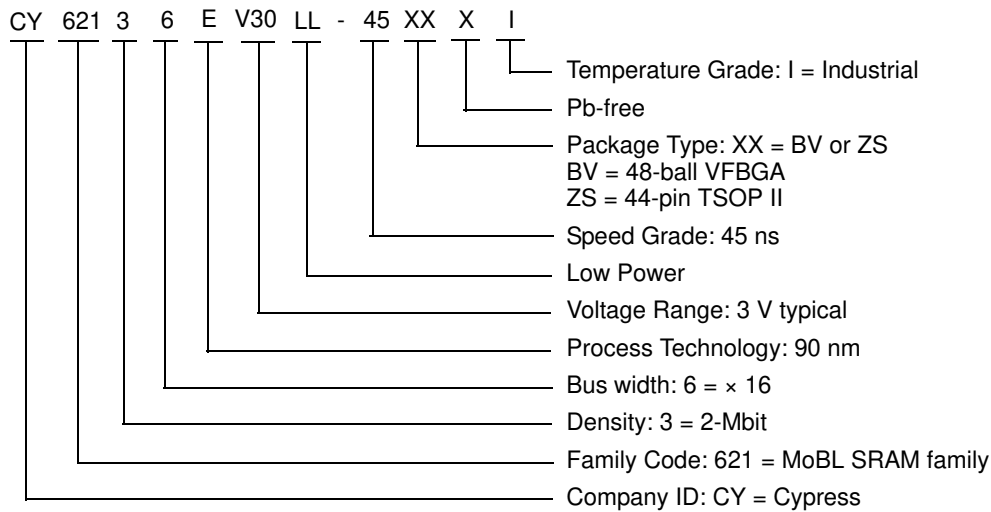

Package Diagrams

Figure 11. 48-ball VFBGA (6 × 8 × 1 mm) BV48/BZ48 Package Outline, 51-85150

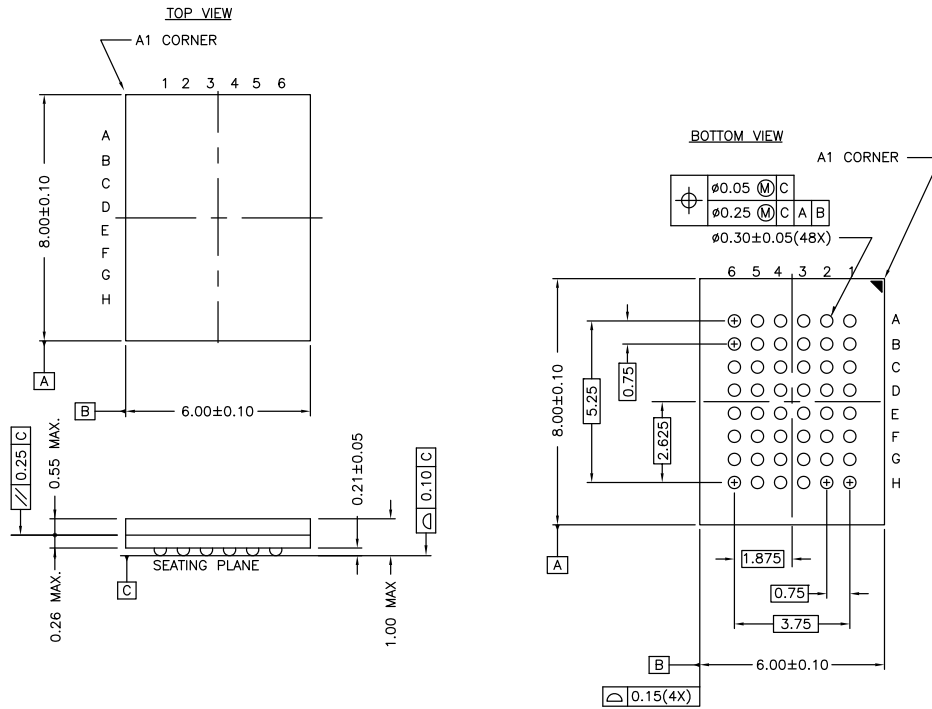

NOTE:
 PACKAGE WEIGHT: See Cypress Package Material Declaration Datasheet (PMDD)
 posted on the Cypress web.

51-85150 *H

Package Diagrams (continued)

Figure 12. 44-pin TSOP Z44-II Package Outline, 51-85087

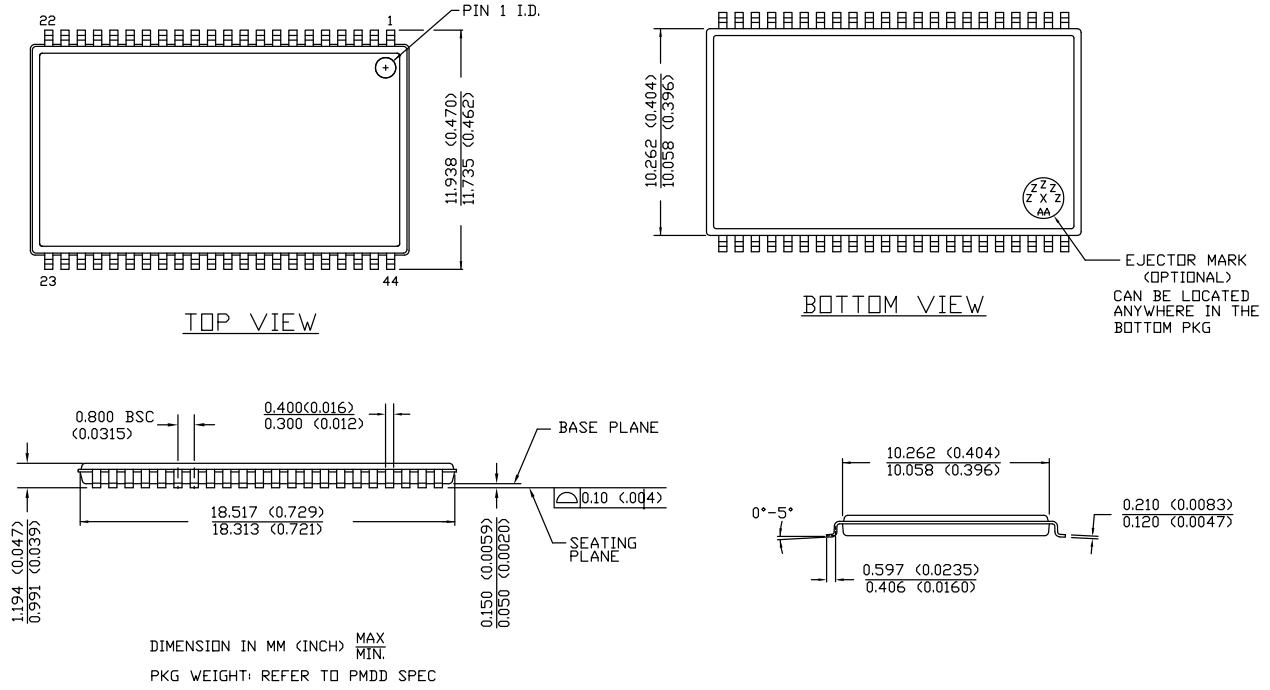

51-85087 *E

Acronyms

Acronym	Description
$\overline{\text{BLE}}$	Byte Low enable
$\overline{\text{BHE}}$	Byte High Enable
$\overline{\text{CE}}$	Chip Enable
CMOS	Complementary Metal Oxide Semiconductor
I/O	Input/Output
$\overline{\text{OE}}$	Output Enable
SRAM	Static Random Access Memory
TSOP	Thin Small Outline Package
VFBGA	Very Fine-Pitch Ball Grid Array
$\overline{\text{WE}}$	Write Enable

Document Conventions

Units of Measure

Symbol	Unit of Measure
°C	degree Celsius
MHz	megahertz
μA	microampere
μs	microsecond
mA	milliampere
mm	millimeter
ns	nanosecond
Ω	ohm
%	percent
pF	picofarad
V	volt
W	watt

Document History Page

Document Title: CY62136EV30 MoBL®, 2-Mbit (128K × 16) Static RAM Document Number: 38-05569				
Rev.	ECN No.	Orig. of Change	Submission Date	Description of Change
**	237432	AJU	See ECN	New data sheet.
*A	419988	R XU	See ECN	<p>Changed status from Advanced Information to Final.</p> <p>Changed the address of Cypress Semiconductor Corporation on Page #1 from "3901 North First Street" to "198 Champion Court"</p> <p>Removed 35ns Speed Bin</p> <p>Removed "L" version of CY62136EV30</p> <p>Changed I_{CC} (Max) value from 2 mA to 2.5 mA and I_{CC} (Typ) value from 1.5 mA to 2 mA at f=1 MHz</p> <p>Changed I_{CC} (Typ) value from 12 mA to 15 mA at f = f_{max}</p> <p>Changed I_{SB1} and I_{SB2} Typ. values from 0.7 μA to 1 μA and Max. values from 2.5 μA to 7 μA.</p> <p>Changed the AC test load capacitance from 50pF to 30pF on Page# 4</p> <p>Changed V_{DR} from 1.5V to 1V on Page# 4.</p> <p>Changed I_{CCDR} from 2.5 μA to 3 μA.</p> <p>Added I_{CCDR} typical value.</p> <p>Changed t_{OHA}, t_{LZCE} and t_{LZWE} from 6 ns to 10 ns</p> <p>Changed t_{LZBE} from 6 ns to 5 ns</p> <p>Changed t_{LZOE} from 3 ns to 5 ns</p> <p>Changed t_{HZOE}, t_{HZCE}, t_{HZBE} and t_{HZWE} from 15 ns to 18 ns</p> <p>Changed t_{SCE}, t_{AW} and t_{BW} from 40 ns to 35 ns</p> <p>Changed t_{PWE} from 30 ns to 35 ns</p> <p>Changed t_{SD} from 20 ns to 25 ns</p> <p>Corrected typo in the Truth Table on Page# 9</p> <p>Updated the package diagram 48-pin VFBGA from *B to *D</p> <p>Updated the ordering Information table and replaced the Package Name column with Package Diagram.</p>
*B	427817	NXR	See ECN	Minor change: Moved datasheet to external web
*C	2604685	VKN / PYRS	11/12/08	<p>Added footnote 8 related to I_{SB2} and I_{CCDR}</p> <p>Added footnote 12 related to AC timing parameters</p>
*D	3144174	RAME	01/17/2011	<p>Added TOC</p> <p>Added Ordering Code Definitions under Ordering Information.</p> <p>Updated Package Diagrams: spec 51-85150 – Changed revision from *D to *F.</p> <p>Added Acronyms and Units of Measure.</p> <p>Converted all tablenotes into footnotes.</p> <p>Updated to new template.</p>
*E	3284728	AJU	06/16/2011	<p>Removed the Note "For best practice recommendations, refer to the Cypress application note "SRAM System Design Guidelines" on http://www.cypress.com." in page 1 and its reference in Functional Description.</p> <p>Updated to new template.</p>
*F	4102185	VINI	08/22/2013	<p>Updated Switching Characteristics:</p> <p>Updated Note 16.</p> <p>Updated Package Diagrams: spec 51-85150 – Changed revision from *F to *H. spec 51-85087 – Changed revision from *C to *E.</p> <p>Updated to new template.</p>
*G	4354908	VINI	04/23/2014	<p>Updated Switching Characteristics:</p> <p>Added Note 20 and referred the same note in "Write Cycle".</p> <p>Updated Switching Waveforms:</p> <p>Added Note 29 and referred the same note in Figure 9.</p> <p>Completing Sunset Review.</p>

Document History Page (continued)

Document Title: CY62136EV30 MoBL [®] , 2-Mbit (128K × 16) Static RAM Document Number: 38-05569				
Rev.	ECN No.	Orig. of Change	Submission Date	Description of Change
*H	4540616	VINI	10/16/2014	Updated Maximum Ratings : Referred Notes 4, 5 in "Supply voltage to ground potential". Updated Switching Waveforms : Updated Note 29.
*I	4576475	VINI	11/21/2014	Updated Functional Description : Added "For a complete list of related documentation, click here. " at the end.
*J	5734096	VINI	05/11/2017	Updated Thermal Resistance : Updated details in "Test Conditions" column and updated all values in "48-ball BGA" and "44-pin TSOP II" columns. Updated to new template. Completing Sunset Review.

Sales, Solutions, and Legal Information

Worldwide Sales and Design Support

Cypress maintains a worldwide network of offices, solution centers, manufacturer's representatives, and distributors. To find the office closest to you, visit us at [Cypress Locations](#).

Products

ARM® Cortex® Microcontrollers	cypress.com/arm
Automotive	cypress.com/automotive
Clocks & Buffers	cypress.com/clocks
Interface	cypress.com/interface
Internet of Things	cypress.com/iot
Memory	cypress.com/memory
Microcontrollers	cypress.com/mcu
PSoC	cypress.com/psoc
Power Management ICs	cypress.com/pmic
Touch Sensing	cypress.com/touch
USB Controllers	cypress.com/usb
Wireless Connectivity	cypress.com/wireless

PSoC® Solutions

[PSoC 1](#) | [PSoC 3](#) | [PSoC 4](#) | [PSoC 5LP](#)

Cypress Developer Community

[Forums](#) | [WICED IOT Forums](#) | [Projects](#) | [Video](#) | [Blogs](#) | [Training](#) | [Components](#)

Technical Support

cypress.com/support

© Cypress Semiconductor Corporation, 2004–2017. This document is the property of Cypress Semiconductor Corporation and its subsidiaries, including Spansion LLC ("Cypress"). This document, including any software or firmware included or referenced in this document ("Software"), is owned by Cypress under the intellectual property laws and treaties of the United States and other countries worldwide. Cypress reserves all rights under such laws and treaties and does not, except as specifically stated in this paragraph, grant any license under its patents, copyrights, trademarks, or other intellectual property rights. If the Software is not accompanied by a license agreement and you do not otherwise have a written agreement with Cypress governing the use of the Software, then Cypress hereby grants you a personal, non-exclusive, nontransferable license (without the right to sublicense) (1) under its copyright rights in the Software (a) for Software provided in source code form, to modify and reproduce the Software solely for use with Cypress hardware products, only internally within your organization, and (b) to distribute the Software in binary code form externally to end users (either directly or indirectly through resellers and distributors), solely for use on Cypress hardware product units, and (2) under those claims of Cypress's patents that are infringed by the Software (as provided by Cypress, unmodified) to make, use, distribute, and import the Software solely for use with Cypress hardware products. Any other use, reproduction, modification, translation, or compilation of the Software is prohibited.

TO THE EXTENT PERMITTED BY APPLICABLE LAW, CYPRESS MAKES NO WARRANTY OF ANY KIND, EXPRESS OR IMPLIED, WITH REGARD TO THIS DOCUMENT OR ANY SOFTWARE OR ACCOMPANYING HARDWARE, INCLUDING, BUT NOT LIMITED TO, THE IMPLIED WARRANTIES OF MERCHANTABILITY AND FITNESS FOR A PARTICULAR PURPOSE. To the extent permitted by applicable law, Cypress reserves the right to make changes to this document without further notice. Cypress does not assume any liability arising out of the application or use of any product or circuit described in this document. Any information provided in this document, including any sample design information or programming code, is provided only for reference purposes. It is the responsibility of the user of this document to properly design, program, and test the functionality and safety of any application made of this information and any resulting product. Cypress products are not designed, intended, or authorized for use as critical components in systems designed or intended for the operation of weapons, weapons systems, nuclear installations, life-support devices or systems, other medical devices or systems (including resuscitation equipment and surgical implants), pollution control or hazardous substances management, or other uses where the failure of the device or system could cause personal injury, death, or property damage ("Unintended Uses"). A critical component is any component of a device or system whose failure to perform can be reasonably expected to cause the failure of the device or system, or to affect its safety or effectiveness. Cypress is not liable, in whole or in part, and you shall and hereby do release Cypress from any claim, damage, or other liability arising from or related to all Unintended Uses of Cypress products. You shall indemnify and hold Cypress harmless from and against all claims, costs, damages, and other liabilities, including claims for personal injury or death, arising from or related to any Unintended Uses of Cypress products.

Cypress, the Cypress logo, Spansion, the Spansion logo, and combinations thereof, WICED, PSoC, CapSense, EZ-USB, F-RAM, and Traveo are trademarks or registered trademarks of Cypress in the United States and other countries. For a more complete list of Cypress trademarks, visit cypress.com. Other names and brands may be claimed as property of their respective owners.