

## LGA C Series

15 - 100 Watts

### Data Sheet

**Total Power:** 15 - 100 W  
**# of Outputs:** Single

#### SPECIAL FEATURES

- 3, 6, 10 and 20 A output current rating
- Wide input voltage range; up to 14 V
- Adjustable output voltage; 0.59-5.1 V
- Excellent transient response
- High efficiency
- Output margining
- Power enable
- Minimal airflow requirement
- Termination voltage capability
- Ultra compact profile and footprint
- RoHS compliant
- Remote sense
- Termination voltage capability

#### SAFETY

- Designed to meet EN60950
- International Standards for Solderability: J-STD-002B IEC-60068-2-58



#### Electrical Specifications

Output		3/6/10 A Models	20 A Model
Output voltage	See Page 3	0.59 - 5.1 V	
Output setpoint accuracy	0.1% trim resistors	±1.0%	
Line regulation		±0.2%	
Load regulation		±0.5%	
Max Current Max Power		15/30/50 W	100 W
Overshoot	At turn-on	0%	
Undershoot	At turn-off	0 mV	
Ripple and noise 5 Hz to 20 MHz	See Note 1 $V_{in} = 5\text{ V}, V_{out} = 2.5\text{ V}$	20/25/30 mV	30 mV
Transient response	See Notes 1 and 2 $V_{in} = 5\text{ V}, V_{out} = 2.5\text{ V}$	100/160/160 mV 15 $\mu\text{s}$ recovery to within regulation band	1175 mV 15 $\mu\text{s}$ recovery to within regulation band
Input			
Input voltage range <sup>3</sup>		3 - 14 Vdc	4.5 - 14 Vdc
Input current	Enable On at (0 A) Enable Off	50 mA 5 mA	
Start-up time	Power up Enable On/Off	3 ms 2 ms	
General			
Efficiency	$V_{in} = 5\text{ V}, V_{out} = 2.5\text{ V}, I_{out} = 50\% I_{max}$	92% typ.	92% typ.
Switching frequency		1 MHz	800 kHz
Material flammability		UL94V-0	
MTBF	12 V @ 40 °C 100% load Bellcore 332	> 20,000,000 hours	
Coplanarity		150 $\mu\text{m}$	
Thermal performance See Technical Reference Note	Operating ambient Non-operating ambient	-40 °C to +85 °C -40 °C to +125 °C	

## Electrical Specifications

Protection		
Short circuit	Hiccup, non-latching	
Overvoltage	Hiccup, non-latching	
Minimum Recommended System Capacitance	3/6/10 A Model	20 A Model
Short circuit	1 $\mu$ F	10 $\mu$ F
Overvoltage	10 $\mu$ F	50 $\mu$ F

## Ordering Information

Standard Model Numbers	Output Power (Max.)	Input Voltage	Output Voltage	Output Current		Efficiency (Typical)	Regulation	
				Min	Max		Min	Max
LGA03C-00SADJJ	15 W	3 - 14.0 Vdc	0.59 - 5.1 Vdc	0 A	3 A	92%	$\pm$ 0.2%	$\pm$ 0.5%
LGA06C-00SADJJ	30 W	3 - 14.0 Vdc	0.59 - 5.1 Vdc	0 A	6 A	92%	$\pm$ 0.2%	$\pm$ 0.5%
LGA10C-00SADJJ	50 W	3 - 14.0 Vdc	0.59 - 5.1 Vdc	0 A	10 A	92%	$\pm$ 0.2%	$\pm$ 0.5%
LGA20C-01SADJJ	100 W	4.5 - 14.0 Vdc	0.59 - 5.1 Vdc	0 A	20 A	91%	$\pm$ 0.2%	$\pm$ 0.5%

## Model Number System with Options



Product Family	Rated Output Current	Performance	Input Voltage	Type of Output	Options	RoHS Compliance
<b>LGA</b>	<b>XX</b>	<b>C</b>	<b>00</b>	<b>SADJ</b>	<b>X</b>	<b>J</b>
Land Grid Array	<b>Rated Output Current</b> 03 = 3 Amp 06 = 6 Amp 10 = 10 Amp 20 = 20 Amp	<b>Performance</b> C = Cost Optimized	<b>Input Voltage</b> 00 = 3 - 14.0 V 01 = 4.5 - 14.0 V	<b>Type of Output</b> Single Adjustable Output	<b>Options</b> X = Various Options (see Sales Rep)	<b>RoHS Compliance</b> J = Pb free (RoHS 6/6 compliant)

## Heatsink Number System with Options



Product Family	Product	Purpose	Height*
<b>LGA</b>	<b>HTSK</b>	<b>KIT</b>	<b>XXX</b>
Land Grid Array	Heatsink	Heatsink and Adhesive	<b>Total Height</b> (LGA20 + Heatsink) 045 = 0.45" 048 = 0.48" 050 = 0.50"

\* Height is the total height of the LGA20C-00SADJJ with heatsink attached.

## Application Equations

### Setting Output Voltage

Default output voltage: 0.591 V

The output voltage may be adjusted with a resistor placed between the "Trim" and "-Sense" pin.

The formula for calculating the value of this resistor is:

$$R_{\text{trim}} \text{ (k}\Omega\text{)} = \frac{1.182}{V_{\text{out}} - 0.591}$$

See Technical Reference Note for other trimming methods.

### Setting Margin Control

To margin the output up, pull the margin control pin high. To margin down, pull the margin control pin low. If the pin is left floating, the feature is disabled. The maximum margining range is  $\pm 33\%$  of the output default voltage setting, with maximum output at 5.5 V

$$V_{\text{margin\_up}} = 0.1182 * \frac{R_{\text{margin}}}{R_{\text{ofs+}}} * \frac{R_{\text{trim}} + 2k}{R_{\text{trim}}}$$

$$V_{\text{margin\_down}} = 0.1182 * \frac{R_{\text{margin}}}{R_{\text{ofs-}}} * \frac{R_{\text{trim}} + 2k}{R_{\text{trim}}}$$

### Setting Under Voltage Lock Out – 3, 6, 10 A Models

Default Turn-on voltage: 2.9 V (300 mV Hysteresis)

The Turn-on voltage may be adjusted with a resistor placed between the "Enable" and "Ground" pins.

The formula for calculating the value of this resistor is:

$$R_{\text{UVLO}} \text{ (k}\Omega\text{)} = \frac{14.81 * 6.81}{(6.81 * V_{\text{Turn\_on}}) - 18.16}$$

**\*ONLY USE WITH OPEN COLLECTOR DEVICE**  
**\*DO NOT DRIVE PIN WITH A VOLTAGE**

### Setting Under Voltage Lock Out – 20 A Models

Default Turn-on voltage: 4.3 V (300 mV Hysteresis)

The Turn-on voltage may be adjusted with a resistor placed between the "Enable" and "Ground" pins.

The formula for calculating the value of this resistor is:

$$R_{\text{UVLO}} \text{ (k}\Omega\text{)} = \frac{30.1 * 4.22}{(8.577 * V_{\text{Turn\_on}}) - 34.32}$$

**\*ONLY USE WITH OPEN COLLECTOR DEVICE**  
**\*DO NOT DRIVE PIN WITH A VOLTAGE**

**Notes:**

1. Measured as per recommended minimum system capacitance.
2.  $di/dt = 10 \text{ A}/\mu\text{s}$ ,  $12 \text{ V}_{\text{in}} = \text{Norm}$ ,  $T_c = 25 \text{ }^\circ\text{C}$ , load change = 50% to 100%  $I_{\text{max}}$ .
3. Internal input capacitance is rated 16 Vdc maximum.

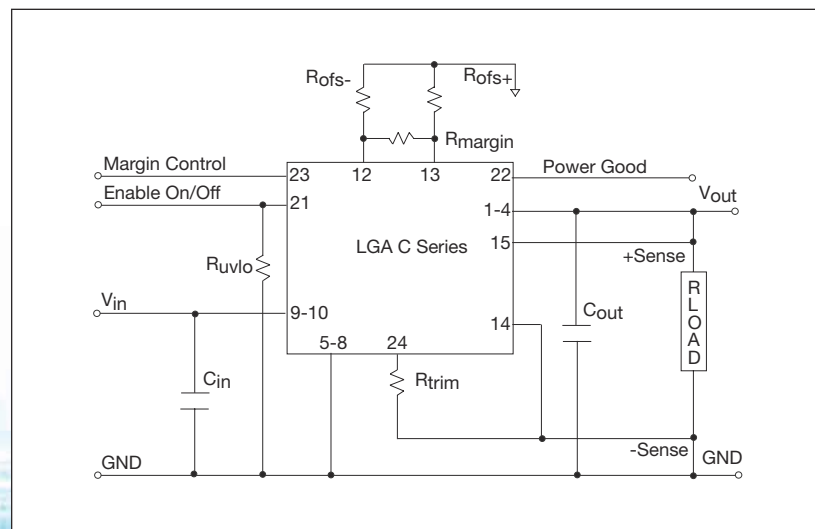

External input fusing is recommended.

## Mechanical Drawing and Footprint

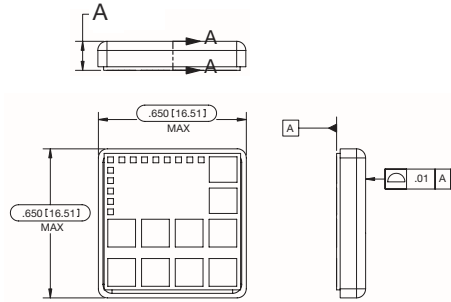

Component Height	
Model #	DIM A in (mm)
LGA03 LGA06 LGA10	0.129 (3.27)
LGA20	0.210 (5.33)

### Recommended System Board Footprint

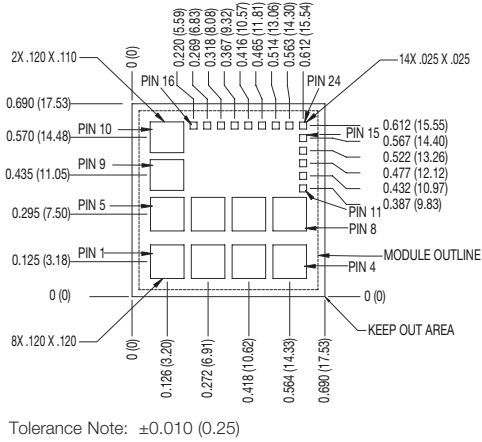

### Pin Assignments

Single Output	
1	Vout
2	Vout
3	Vout
4	Vout
5	GND
6	GND
7	GND
8	GND
9	Vin
10	Vin
11	NC
12	- Offset
13	+ Offset
14	- Sense
15	+ Sense
16	NC
17	NC
18	NC
19	NC
20	NC
21	Enable
22	Power Good
23	Margin Control
23	Trim

### Recommended Solder Paste Stencil

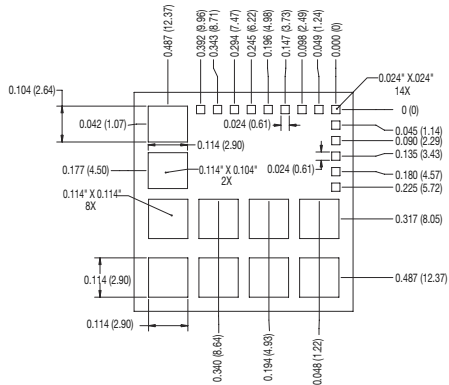

## WORLDWIDE OFFICES

### Americas

2900 S.Diablo Way  
Tempe, AZ 85282  
USA  
+1 888 412 7832

### Europe (UK)

Waterfront Business Park  
Merry Hill, Dudley  
West Midlands, DY5 1LX  
United Kingdom  
+44 (0) 1384 842 211

### Asia (HK)

14/F, Lu Plaza  
2 Wing Yip Street  
Kwun Tong, Kowloon  
Hong Kong  
+852 2176 3333



[www.artesyn.com](http://www.artesyn.com)

Artesyn Embedded Technologies, Artesyn and the Artesyn Embedded Technologies logo are trademarks and service marks of Artesyn Embedded Technologies, Inc. All other names and logos referred to are trade names, trademarks, or registered trademarks of their respective owners. © 2018 Artesyn Embedded Technologies, Inc. All rights reserved. For full legal terms and conditions, please visit [www.artesyn.com/legal](http://www.artesyn.com/legal).

For more information: [www.artesyn.com/power](http://www.artesyn.com/power)  
For support: [productsupport.ep@artesyn.com](mailto:productsupport.ep@artesyn.com)