

## Low voltage fast-switching PNP power transistor

Datasheet - production data

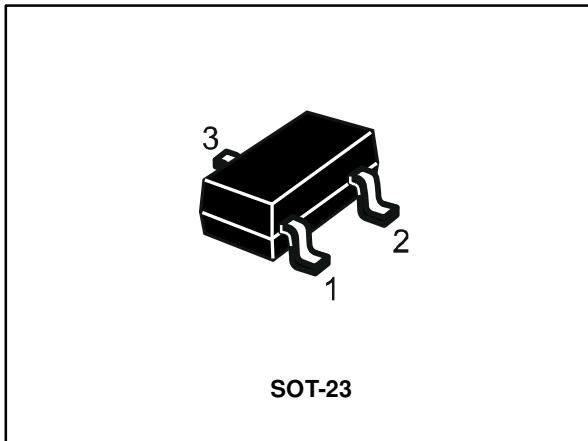
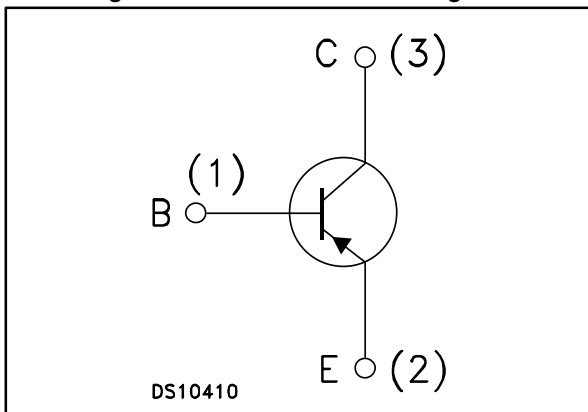

Figure 1: Internal schematic diagram



### Features

- Very low collector-emitter saturation voltage
- High current gain characteristic
- Fast switching speed
- Miniature SOT-23 plastic package for surface mounting circuits

### Applications

- LED
- Battery charger
- Motor and relay driver
- Voltage regulation

### Description

The device is a PNP transistor manufactured using new "PB-HCD" (power bipolar high current density) technology. The resulting transistor shows exceptional high gain performances coupled with very low saturation voltage.

The complementary NPN is the 2STR1160.

Table 1: Device summary

Order code	Marking	Package	Packing
2STR2160	2160	SOT-23	Tape and reel

---

## Contents

<b>1</b>	<b>Electrical ratings .....</b>	<b>3</b>
<b>2</b>	<b>Electrical characteristics .....</b>	<b>4</b>
<b>3</b>	<b>Package mechanical data .....</b>	<b>5</b>
	3.1 SOT-23 mechanical data .....	5
<b>4</b>	<b>Revision history .....</b>	<b>7</b>

# 1 Electrical ratings

**Table 2: Absolute maximum rating**

Symbol	Parameter	Value	Unit
V <sub>CB0</sub>	Collector-base voltage (I <sub>E</sub> = 0)	-60	V
V <sub>CE0</sub>	Collector-emitter voltage (I <sub>B</sub> = 0)	-60	V
V <sub>EB0</sub>	Emitter-base voltage (I <sub>C</sub> = 0)	-5	V
I <sub>C</sub>	Collector current	-1	A
I <sub>CM</sub>	Collector peak current (t <sub>P</sub> < 5ms)	-2	A
P <sub>tot</sub>	Total dissipation at T <sub>amb</sub> = 25°C	0.5	W
T <sub>stg</sub>	Storage temperature	-65 to 150	°C
T <sub>J</sub>	Max. operating junction temperature	150	°C

**Table 3: Thermal data**

Symbol	Parameter	Value	Unit
R <sub>thj-amb</sub> <sup>(1)</sup>	Thermal resistance junction-amb max	250	°C/W

**Notes:**

<sup>(1)</sup>Device mounted on PCB area of 1 cm<sup>2</sup>

## 2 Electrical characteristics

( $T_{\text{case}} = 25^{\circ}\text{C}$  unless otherwise specified)

**Table 4: Electrical characteristics**

Symbol	Parameter	Test conditions	Min.	Typ.	Max.	Unit
$I_{\text{CBO}}$	Collector cut-off current ( $I_{\text{E}} = 0$ )	$V_{\text{CB}} = -60 \text{ V}$			-0.1	$\mu\text{A}$
$I_{\text{EBO}}$	Emitter cut-off current ( $I_{\text{C}} = 0$ )	$V_{\text{EB}} = -5 \text{ V}$			-0.1	$\mu\text{A}$
$V_{(\text{BR})\text{CBO}}$	Collector-base breakdown voltage ( $I_{\text{E}} = 0$ )	$I_{\text{C}} = -100 \mu\text{A}$	-60			V
$V_{(\text{BR})\text{CEO}}^{(1)}$	Collector-emitter breakdown voltage ( $I_{\text{B}} = 0$ )	$I_{\text{C}} = -10 \text{ mA}$	-60			V
$V_{(\text{BR})\text{EBO}}$	Emitter-base breakdown voltage ( $I_{\text{C}} = 0$ )	$I_{\text{E}} = -100 \mu\text{A}$	-5			V
$V_{\text{CE(sat)}}$	Collector-emitter saturation voltage	$I_{\text{C}} = -0.5 \text{ A } I_{\text{B}} = -50 \text{ mA}$			260	mV
		$I_{\text{C}} = -1 \text{ A } I_{\text{B}} = -100 \text{ mA}$			480	mV
$V_{\text{BE(sat)}}$	Base-emitter saturation voltage	$I_{\text{C}} = -1 \text{ A } I_{\text{B}} = -100 \text{ mA}$			1.3	V
$h_{\text{FE}}$	DC current gain	$I_{\text{C}} = -0.5 \text{ A } V_{\text{CE}} = -2 \text{ V}$	180		560	
		$I_{\text{C}} = -1 \text{ A } V_{\text{CE}} = -2 \text{ V}$	45			
		$I_{\text{C}} = -2 \text{ A } V_{\text{CE}} = -2 \text{ V}$		30		
	Resistive load					
$t_{\text{on}}$	Turn-on time	$I_{\text{C}} = -1.5 \text{ A } V_{\text{CC}} = -10 \text{ V}$		220		ns
$t_{\text{off}}$	Turn-off time	$I_{\text{B}1} = -I_{\text{B}2} = -150 \text{ mA}$ $V_{\text{BB(off)}} = 5 \text{ V}$		500		ns

**Notes:**

<sup>(1)</sup>Pulse test: pulse duration = 300  $\mu\text{s}$ , duty cycle  $\leq 1.5 \%$

### 3 Package mechanical data

In order to meet environmental requirements, ST offers these devices in different grades of ECOPACK® packages, depending on their level of environmental compliance. ECOPACK® specifications, grade definitions and product status are available at: [www.st.com](http://www.st.com). ECOPACK® is an ST trademark.

#### 3.1 SOT-23 mechanical data

Figure 2: SOT-23 mechanical drawing

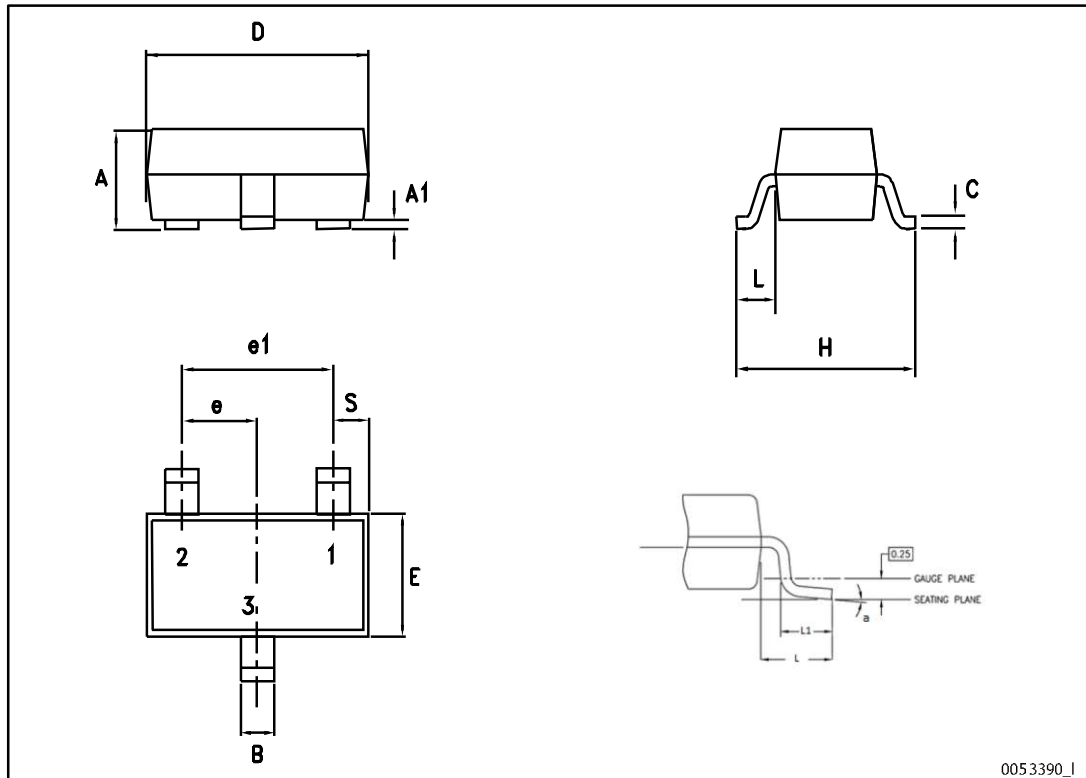
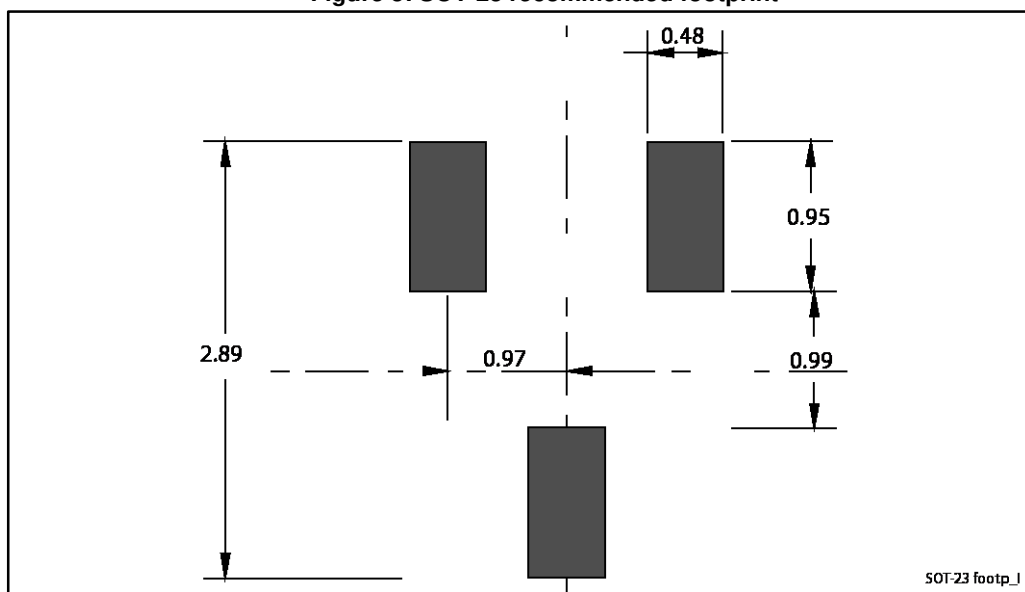

Table 5: SOT-23 mechanical data

Dim.	mm		
	Min.	Typ.	Max.
A	0.89		1.40
A1	0		0.10
B	0.30		0.51
C	0.085		0.18
D	2.75		3.04
e	0.85		1.05
e1	1.70		2.10
E	1.20		1.75
H	2.10		3.00
L		0.60	
S	0.35		0.65
L1	0.25		0.55
a	0°		8°

Figure 3: SOT-23 recommended footprint



Dimensions are in mm.

## 4 Revision history

**Table 6: Document revision history**

Date	Revision	Changes
18-Jun-2008	1	Initial release
08-May-2014	2	Updated <a href="#">Section 3: "Package mechanical data"</a> .
13-Mar-2015	3	Updated marking in <a href="#">Table 1: "Device summary"</a>

**IMPORTANT NOTICE – PLEASE READ CAREFULLY**

STMicroelectronics NV and its subsidiaries ("ST") reserve the right to make changes, corrections, enhancements, modifications, and improvements to ST products and/or to this document at any time without notice. Purchasers should obtain the latest relevant information on ST products before placing orders. ST products are sold pursuant to ST's terms and conditions of sale in place at the time of order acknowledgement.

Purchasers are solely responsible for the choice, selection, and use of ST products and ST assumes no liability for application assistance or the design of Purchasers' products.

No license, express or implied, to any intellectual property right is granted by ST herein.

Resale of ST products with provisions different from the information set forth herein shall void any warranty granted by ST for such product.

ST and the ST logo are trademarks of ST. All other product or service names are the property of their respective owners.

Information in this document supersedes and replaces information previously supplied in any prior versions of this document.

© 2015 STMicroelectronics – All rights reserved