

PART NUMBER	REVISION	DESCRIPTION	FEED TYPE
2150288-1	B	FINE CRIMP HEIGHT ADJUST	MECHANICAL
2150288-2	B	FINE CRIMP HEIGHT ADJUST	PNEUMATIC
7-2150288-1	B	MECHANICAL AND CRIMP TOOLING KIT	MECHANICAL
7-2150288-2	B	PNEUMATIC AND CRIMP TOOLING KIT	PNEUMATIC
7-2150288-7	A	CRIMP TOOLING KIT	-

ATLANTIC VERSION TERMINATOR INTERFACE ADAPTER

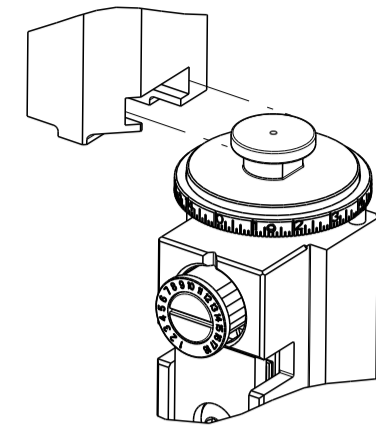

APPLICATOR DATA		
CRIMP	SIZE	TYPE
WIRE	1.14 mm [.045]	F
INSUL	2.29 mm [.090]	F
APPL INSTRUCTIONS 408-35043		

TERMINAL DATA: TE TERMINAL		TE CRIMP SPECIFICATION	
TERMINAL NAME: 110 FLG FAST RCPT 26-22 PTPBR			
WIRE STRIP LENGTH		INSULATION DIAMETER RANGE	
4.24-5.00 mm [.167-.197 IN]		∅1.78-2.54 mm [.070-.100 IN]	
TERMINAL APPLICATION SPECIFICATION	114-2028		
TERMINALS APPLIED			
TE TERMINAL	TE TERMINAL	TE TERMINAL	TE TERMINAL
1742968-1			

WIRE SIZE	CRIMP HEIGHT mm [INCH]	CRIMP HEIGHT REFERENCE SETTING
24 AWG	0.787+/-0.050 [.031+/- .002]	9.5
26 AWG	0.737+/-0.050 [.029+/- .002]	10.0



- △ RECOMMENDED SPARE PARTS
- △ REFER TO SUPPLIED INSTRUCTION SHEET FOR CLEANING, LUBRICATION AND STORAGE OF APPLICATOR.
- △ APPLY PART NUMBER 2-23419-6 LOCTITE TO THREADS OF ITEM 242.
- △ CRIMP HEIGHT REFERENCE SETTING WAS THE SETTING USED WHEN THE APPLICATOR WAS QUALIFIED AT THE FACTORY. ADJUSTMENT MAY BE NECESSARY WHEN RUNNING APPLICATOR IN THE FIELD.
- △ LOCATE FEED FINGER BIASED TOWARDS FRONT STRIP GUIDE TO AVOID BODY OF THE TERMINAL.
- 6. UNLESS SPECIFIED OTHERWISE TORQUE VALUES SHALL BE USED PER DOCUMENT, 101-35000.

***WARNING**
ON INSTALLATION, SET WIRE DISC TO CRIMP HEIGHT REFERENCE SETTING FOR LARGEST WIRE SIZE. CRIMP HEIGHT REFERENCE SETTINGS GREATER THAN THE VALUE SHOWN MAY CAUSE DAMAGE TO THE CRIMP TOOLING. REFER TO THE INSTRUCTION SHEET FOR PROPER SETUP AND ADJUSTMENTS.

LOC	DIST	REVISIONS					
		P	LTN	DESCRIPTION	DATE	DWN	APVD
A	66			RELEASED	06MAR2013	RK	GB
		B		ECR-19-018033	19NOV2019	TB	RK
		B1		ECR-19-018265	21NOV2019	TB	RK

-	1	-	1	-	2119641-1	FEED CAM, AIR FEED	248	
-	1	1	1	1	2119082-7	CAM, SNAIL, INSULATION ADJUSTMENT	244	
-	1	1	1	1	2079764-1	WASHER, WAVE SPRING, CREST-TO-CREST	243	
△	1	1	1	1	2119083-1	RETAINER, INSULATION DIAL	242	
-	-	1	-	1	2119580-1	MECHANICAL FEED ASSEMBLY	239	
-	1	-	1	-	2844940-3	AIR FEED MODULE	238	
-	1	1	1	1	1-18028-0	WASHER, FLAT, REG M8	192	
-	REF	REF	REF	REF	994970-2	COUNTER, MAGNETIC	164	
-	1	1	1	1	455888-6	SPACER, CRIMPER	82	
-	1	1	1	1	2119791-9	DEPRESSOR, WIRE	73	
-	1	1	1	1	1803607-4	DOCUMENTATION PACKAGE	71	
-	2	2	2	2	2-18032-2	SCR, SET, FLT PNT, M3 X 10.0	70	
-	1	1	1	1	2119740-1	TAG, IDENTIFICATION	67	
-	2	2	2	2	2168078-1	SCREW, DRIVE, RH, RoHS, 2 x .188	66	
-	1	1	1	1	2168083-2	SCR, SKT HD CAP, RoHS, M4 X 8.0	60	
-	1	1	1	1	5-18022-5	SCR, HEX HD CAP, M4 X 6.0	59	
△	-	1	-	1	2063961-1	FEED FINGER	58	
-	4	4	4	4	2168400-1	SHCS, LOW HEAD, RoHS, M4 X 12	57	
-	2	2	2	2	2168083-5	SCR, SKT HD CAP, RoHS, M4 X 6.0	56	
-	2	2	2	2	5018030-1	NUT, HEX, REG, RoHS, M3	54	
-	2	2	2	2	986965-8	NUT, LOCK, HEX, TORQUE (M4)	53	
△	1	-	1	-	1-2063961-0	FEED FINGER	51	
-	1	2	1	2	18023-9	SCR, SKT HD CAP M4 X 6.0	49	
-	-	1	-	1	2119652-1	FEED CAM, PRE FEED	48	
-	-	1	-	1	2119653-1	FEED CAM, POST FEED	47	
-	1	1	1	1	2119655-5	APPLICATOR BASIC ASSEMBLY, EF	46	
-	1	1	1	1	1803517-1	RAM ASSEMBLY, EF ATLANTIC	44	
-	1	1	1	1	1803602-1	SCR, BHSC, RoHS (M8 X 25)	41	
-	8	8	8	8	1-18028-2	WASHER, FLAT, REG M4	33	
-	2	2	2	2	2168083-9	SCR, SKT HD CAP, RoHS, M4 X 20	31	
-	2	2	2	2	2168083-2	SCR, SKT HD CAP, RoHS, M4 X 8.0	29	
-	1	1	1	1	690455-2	STRIPPER, FRONT CASTING	27	
-	2	2	2	2	1-2168083-5	SCR, SKT HD CAP, RoHS, M4 X 30	25	
-	1	1	1	1	1752371-5	PLATE, STRIP GUIDE	24	
-	2	2	2	2	22281-7	SPRING, COMPRESSION	22	
-	1	1	1	1	1803292-4	DRAG	20	
-	1	1	1	1	1803086-1	GUIDE, REAR STRIP	19	
-	1	1	1	1	1803100-1	GUIDE, FRONT STRIP	18	
-	4	4	4	4	1-2079383-1	SCR, BHSC, RoHS (M6 X 12)	17	
△	1	1	1	1	240644-1	PLATE, REAR SHEAR	11	
-	-	-	-	-	-	-	10	
△	1	1	1	1	2-690482-4	PLATE, FRONT SHEAR	9	
△	1	2	2	1	1-1803001-2	ANVIL, COMBINATION, END FEED	8	
△	1	1	1	1	1803088-1	BLADE, SLUG	7	
-	1	1	1	1	3-240641-8	SPACER	5	
-	1	1	1	1	238011-9	BLOCK, CRIMPER SPACER	4	
△	1	2	2	1	7-2119582-3	CRIMPER, INSULATION F PREMIUM	3	
-	-	-	-	-	-	-	2	
△	1	2	2	1	5-1633664-0	CRIMPER, WIRE	1	
-	77	72	71	2	-1	PART NO	DESCRIPTION	ITEM NO

ATLANTIC VERSION
Shown on sheets 1 of 4 & 2 of 4
(Pacific version shown on sheets 3 of 4 & 4 of 4)

DIMENSIONS:		TOLERANCES UNLESS OTHERWISE SPECIFIED:		MATERIAL:		FINISH:	
mm	0 PLC ±	1 PLC ±	2 PLC ±	3 PLC ±	4 PLC ±	ANGLES	
MATERIAL:				FINISH:			

DWN	R. KNEPPER	13DEC2012	
CHK	T. ELBIN	13DEC2012	
APVD	M. CLIFFORD	13DEC2012	
NAME	Ocean End Feed Applicator		
SIZE	CAGE CODE	DRAWING NO	RESTRICTED TO
A1	00779	2150288	
Customer Accessible Production Drawing			
SCALE	1:1	SHEET	1 of 4
REV	B1		

LOC		DIST		REVISIONS			
A	66	P	LTM	DESCRIPTION	DATE	OWN	APVD
		-		SEE SHEET 1			

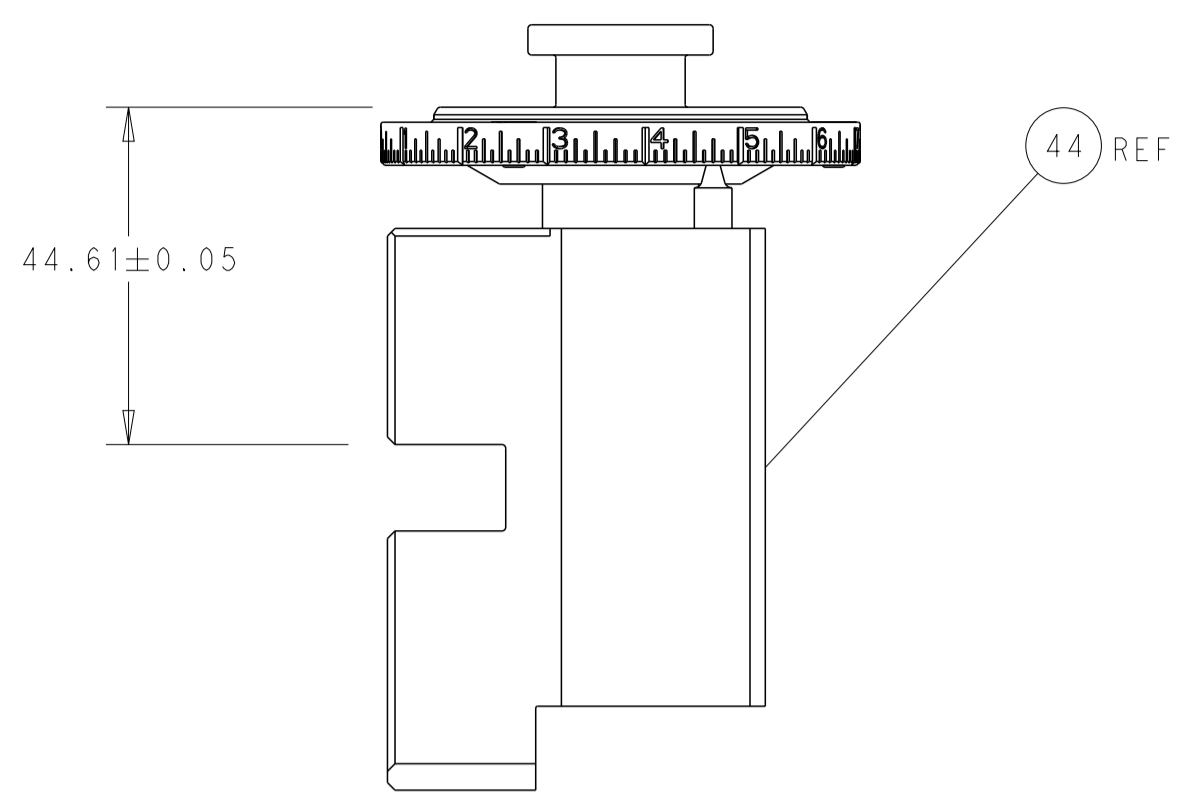

RAM SET-UP

FEED TYPE MECHANICAL

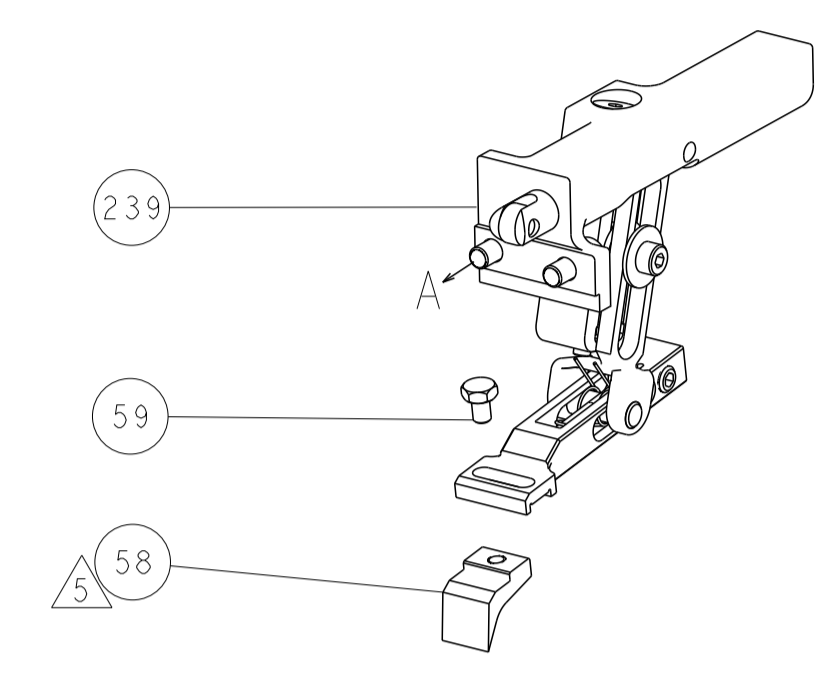

PNEUMATIC

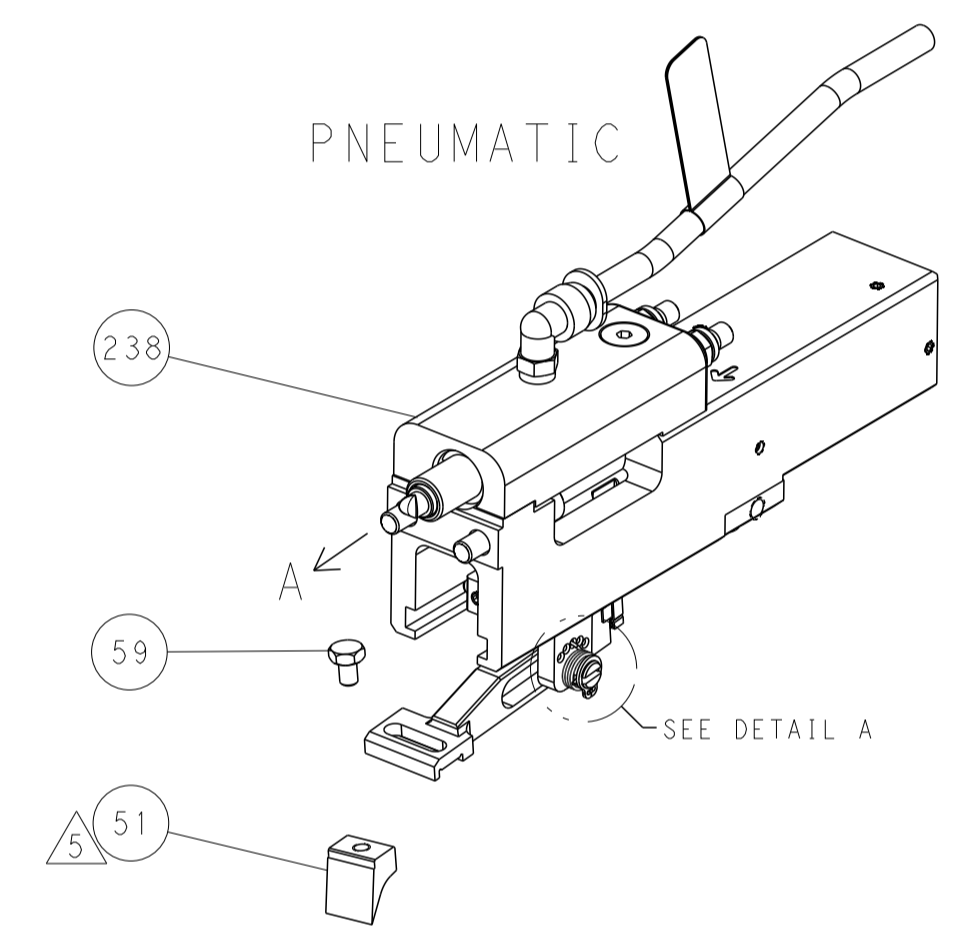

FEED SPRING SETTING POSITION

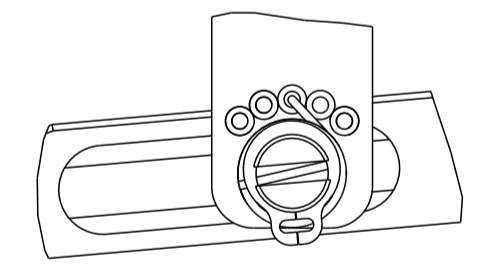

DETAIL A

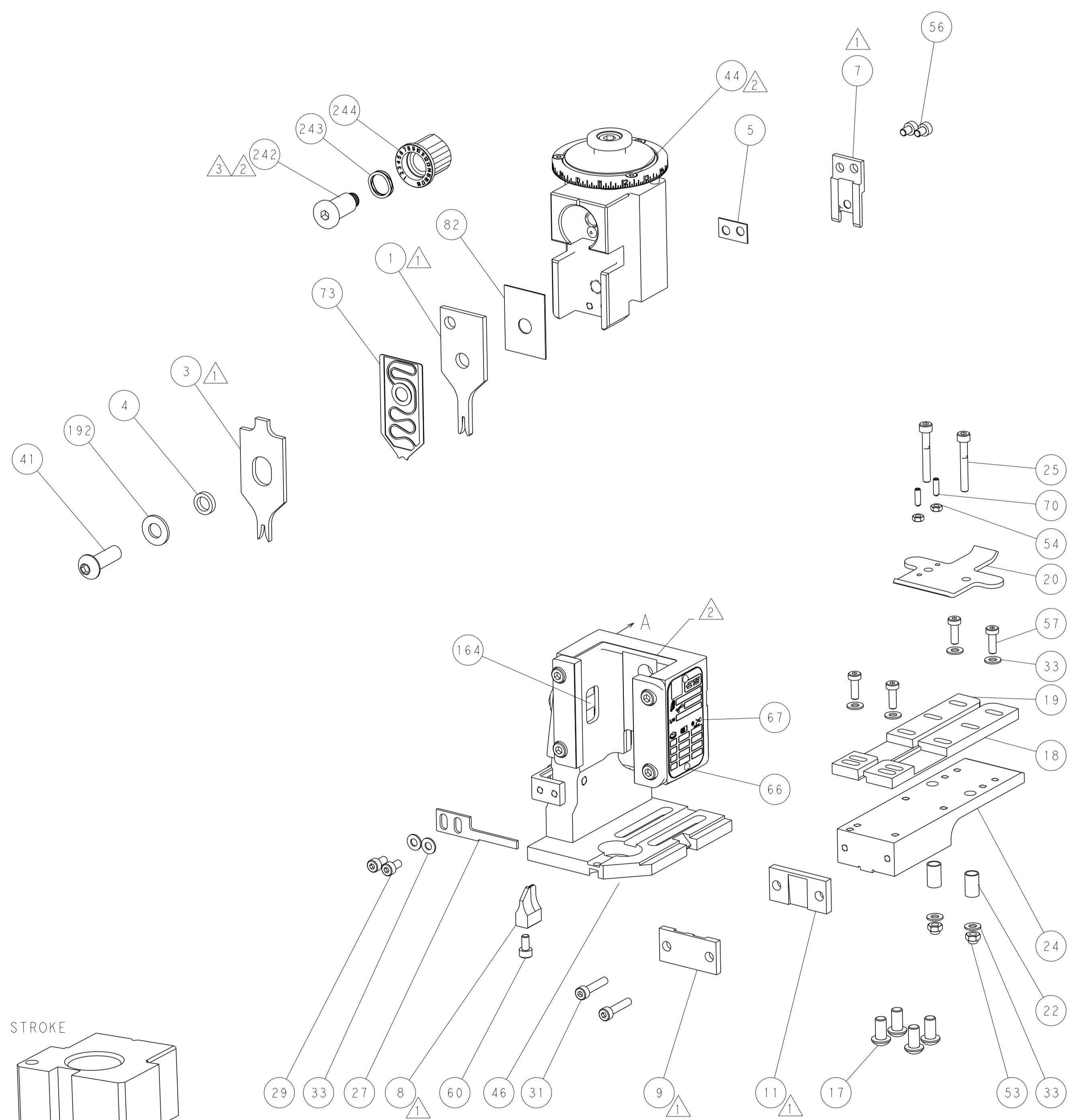

CAM POSITIONS

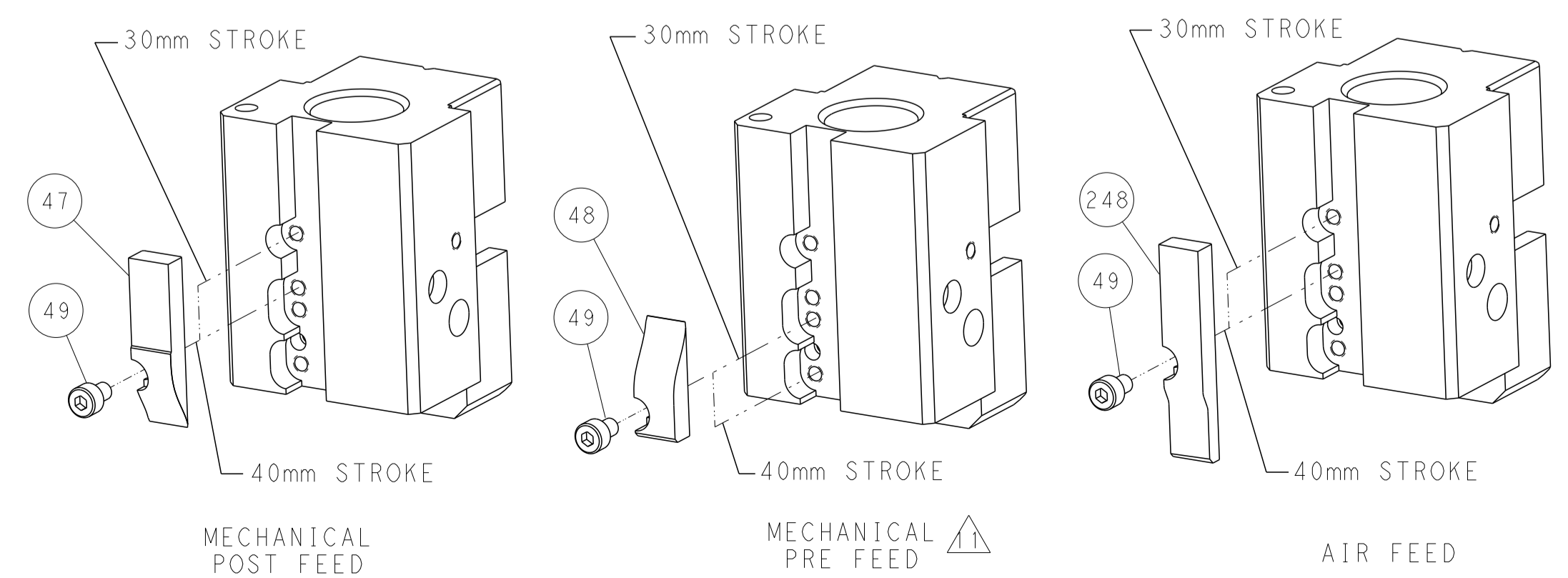

ATLANTIC VERSION
 Shown on sheets 1 of 4 & 2 of 4
 (Pacific version shown on sheets 3 of 4 & 4 of 4)

DIMENSIONS:		TOLERANCES UNLESS OTHERWISE SPECIFIED:		OWN: R. KNEPPER 13DEC2012		TE Connectivity	
mm		0 PLC ±		CHK: T. ELBIN 13DEC2012		Harrisburg, PA 17105-3608	
Ø		1 PLC ±		APVD: M. CLIFFORD 13DEC2012		NAME: Ocean End Feed Applicator	
H		2 PLC ±		PRODUCT SPEC		SIZE: CAGE CODE: DRAWING NO:	
D		3 PLC ±		APPLICATION SPEC		RESTRICTED TO:	
R		4 PLC ±		WEIGHT		A1 00779 ©=2150288	
ANGLES		FINISH		Customer Accessible Production Drawing		SCALE: 1:1 SHEET 2 OF 4 REV: B1	

PART NUMBER	REVISION	DESCRIPTION	FEED TYPE
2-2150288-1	B	FINE CRIMP HEIGHT ADJUST	MECHANICAL
2-2150288-2	B	FINE CRIMP HEIGHT ADJUST	PNEUMATIC
7-2150288-7	A	CRIMP TOOLING KIT	-

PACIFIC VERSION TERMINATOR
 INTERFACE ADAPTER

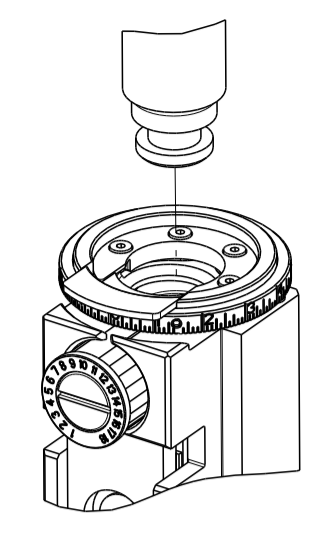

APPLICATOR DATA		
CRIMP	SIZE	TYPE
WIRE	1.14 mm [.045]	F
INSUL	2.29 mm [.090]	F
APPL INSTRUCTIONS 408-35043		

TERMINAL DATA: TE TERMINAL		TE CRIMP SPECIFICATION	
TERMINAL NAME: 110 FLG FAST RCPT 26-22 PTPBR			
WIRE STRIP LENGTH 4.24-5.00 mm [.167-.197 IN]		INSULATION DIAMETER RANGE Ø1.78-2.54 mm [.070-.100 IN]	
TERMINAL APPLICATION SPECIFICATION	114-2028	-	-
TERMINALS APPLIED			
TE TERMINAL	TE TERMINAL	TE TERMINAL	TE TERMINAL
1742968-1			

WIRE SIZE	CRIMP HEIGHT mm [INCH]	CRIMP HEIGHT REFERENCE SETTING
24 AWG	0.787+/-0.050 [.031+/- .002]	9.5
26 AWG	0.737+/-0.050 [.029+/- .002]	10.0

- RECOMMENDED SPARE PARTS
- REFER TO SUPPLIED INSTRUCTION SHEET FOR CLEANING, LUBRICATION AND STORAGE OF APPLICATOR.
- APPLY PART NUMBER 2-23419-6 LOCTITE TO THREADS OF ITEM 242.
- CRIMP HEIGHT REFERENCE SETTING WAS THE SETTING USED WHEN THE APPLICATOR WAS QUALIFIED AT THE FACTORY. ADJUSTMENT MAY BE NECESSARY WHEN RUNNING APPLICATOR IN THE FIELD.
- LOCATE FEED FINGER BIASED TOWARDS FRONT STRIP GUIDE TO AVOID BODY OF THE TERMINAL.
- 6. UNLESS SPECIFIED OTHERWISE TORQUE VALUES SHALL BE USED PER DOCUMENT, 101-35000.

***WARNING**
 ON INSTALLATION, SET WIRE DISC TO CRIMP HEIGHT REFERENCE SETTING FOR LARGEST WIRE SIZE. CRIMP HEIGHT REFERENCE SETTINGS GREATER THAN THE VALUE SHOWN MAY CAUSE DAMAGE TO THE CRIMP TOOLING. REFER TO THE INSTRUCTION SHEET FOR PROPER SETUP AND ADJUSTMENTS.

LOC	DIST	REVISIONS					
		P	LTN	DESCRIPTION	DATE	OWN	APVD
A	66	-	-	SEE SHEET 1	-	-	-

-	1	1	2119082-7	CAM, SNAIL, INSULATION ADJUSTMENT	244	
-	1	1	2079764-1	WASHER, WAVE SPRING, CREST-TO-CREST	243	
-	1	1	2119083-1	RETAINER, INSULATION DIAL	242	
-	-	1	2119580-1	MECHANICAL FEED ASSEMBLY	239	
-	1	-	2844940-3	AIR FEED MODULE	238	
-	1	1	1-18028-0	WASHER, FLAT, REG M8	192	
-	4	4	2079383-9	SCR, BHSC, RoHS (M6 X 20)	186	
-	REF	REF	994970-2	COUNTER, MAGNETIC	164	
-	1	-	2119641-2	FEED CAM, AIR FEED	152	
-	1	1	2168083-8	SCR, SKT HD CAP, RoHS, M4 X 16	144	
-	-	1	2119653-2	FEED CAM, POST FEED	142	
-	1	1	2119655-6	APPLICATOR BASIC ASSEMBLY, EF	141	
-	1	1	1803518-1	RAM ASSEMBLY, EF PACIFIC	140	
-	1	1	455888-6	SPACER, CRIMPER	82	
-	1	1	2119791-9	DEPRESSOR, WIRE	73	
-	1	1	1803607-4	DOCUMENTATION PACKAGE	71	
-	2	2	2-18032-2	SCR, SET, FLT PNT, M3 X 10.0	70	
-	1	1	2119740-1	TAG, IDENTIFICATION	67	
-	2	2	2168078-1	SCREW, DRIVE, RH, RoHS, 2 x .188	66	
-	1	1	5-18022-5	SCR, HEX HD CAP, M4 X 6.0	59	
-	-	1	2063961-1	FEED FINGER	58	
-	4	4	2168400-1	SHCS, LOW HEAD, RoHS, M4 X 12	57	
-	2	2	2168083-5	SCR, SKT HD CAP, RoHS, M4 X 6.0	56	
-	2	2	5018030-1	NUT, HEX, REG, RoHS, M3	54	
-	2	2	986965-8	NUT, LOCK, HEX, TORQUE (M4)	53	
-	1	-	1-2063961-0	FEED FINGER	51	
-	1	2	18023-9	SCR, SKT HD CAP M4 X 6.0	49	
-	-	1	2119652-1	FEED CAM, PRE FEED	48	
-	1	1	1803602-1	SCR, BHSC, RoHS (M8 X 25)	41	
-	8	8	1-18028-2	WASHER, FLAT, REG M4	33	
-	2	2	2168083-9	SCR, SKT HD CAP, RoHS, M4 X 20	31	
-	2	2	2168083-2	SCR, SKT HD CAP, RoHS, M4 X 8.0	29	
-	1	1	690455-2	STRIPPER, FRONT CASTING	27	
-	2	2	1-2168083-5	SCR, SKT HD CAP, RoHS, M4 X 30	25	
-	1	1	1752371-5	PLATE, STRIP GUIDE	24	
-	2	2	22281-7	SPRING, COMPRESSION	22	
-	1	1	1803292-4	DRAG	20	
-	1	1	1803086-1	GUIDE, REAR STRIP	19	
-	1	1	1803100-1	GUIDE, FRONT STRIP	18	
-	1	1	240644-1	PLATE, REAR SHEAR	11	
-	-	-	-	-	10	
-	1	1	2-690482-4	PLATE, FRONT SHEAR	9	
-	1	1	1-1803001-2	ANVIL, COMBINATION, END FEED	8	
-	1	1	1803088-1	BLADE, SLUG	7	
-	1	1	3-240641-8	SPACER	5	
-	1	1	238011-9	BLOCK, CRIMPER SPACER	4	
-	1	1	7-2119582-3	CRIMPER, INSULATION F PREMIUM	3	
-	-	-	-	-	2	
-	1	1	5-1633664-0	CRIMPER, WIRE	1	
-	77	22	21	PART NO	DESCRIPTION	ITEM NO

PACIFIC VERSION
 Shown on sheets 3 of 4 & 4 of 4
 (Atlantic version shown on sheets 1 of 4 & 2 of 4)

DIMENSIONS: mm 		TOLERANCES UNLESS OTHERWISE SPECIFIED: 0 PLC ± 1 PLC ± 2 PLC ± 3 PLC ± 4 PLC ± ANGLES ± FINISH		DWN R. KNEPPER 13DEC2012 CHK T. ELBIN 13DEC2012 APVD M. CLIFFORD 13DEC2012 PRODUCT SPEC APPLICATION SPEC WEIGHT SCALE 1:1 SHEET 3 OF 4 REV B1		NAME Ocean End Feed Applicator SIZE CAGE CODE DRAWING NO RESTRICTED TO A1 00779 C=2150288	
MATERIAL:				Customer Accessible Production Drawing			

LOC	DIST	REVISIONS			
P	LTN	DESCRIPTION	DATE	DMN	APVD
A	66	SEE SHEET 1	-	-	-

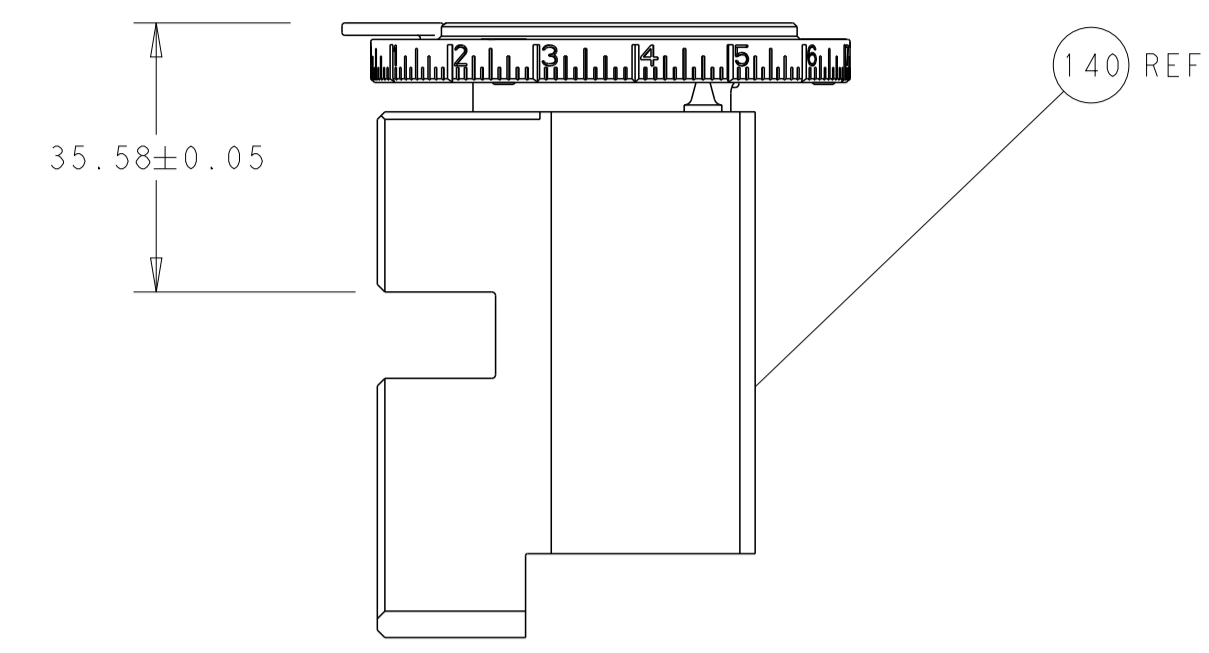

RAM SET-UP

FEED TYPE MECHANICAL

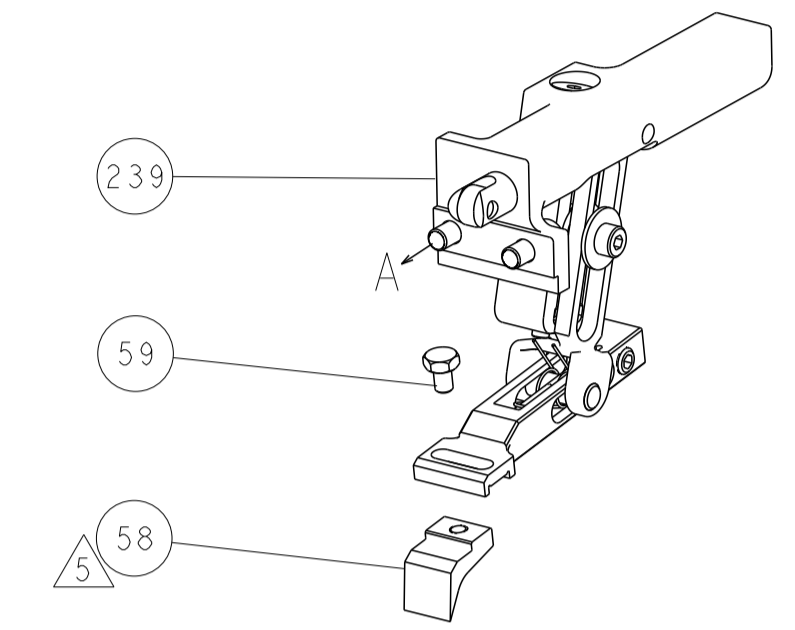

PNEUMATIC

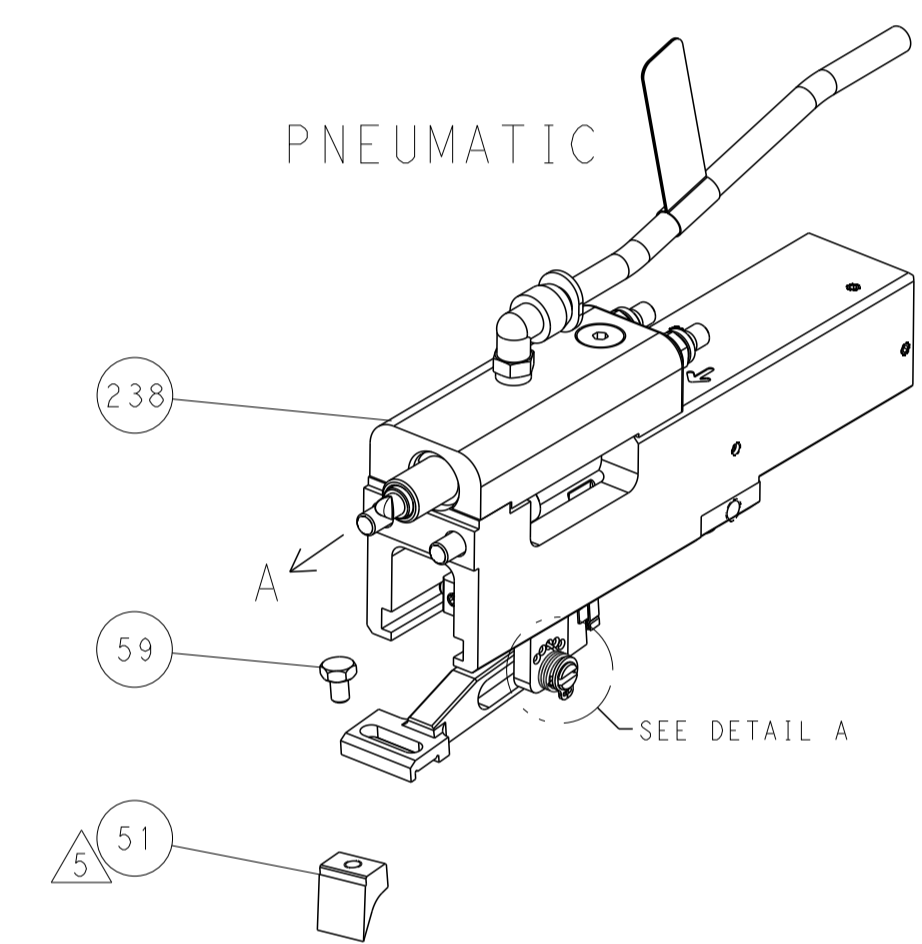

FEED SPRING SETTING POSITION

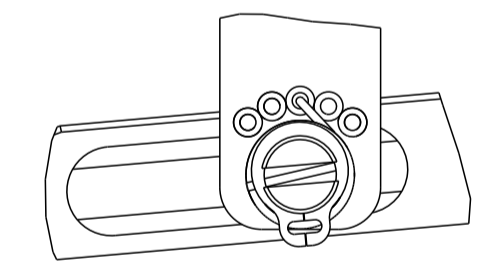

DETAIL A

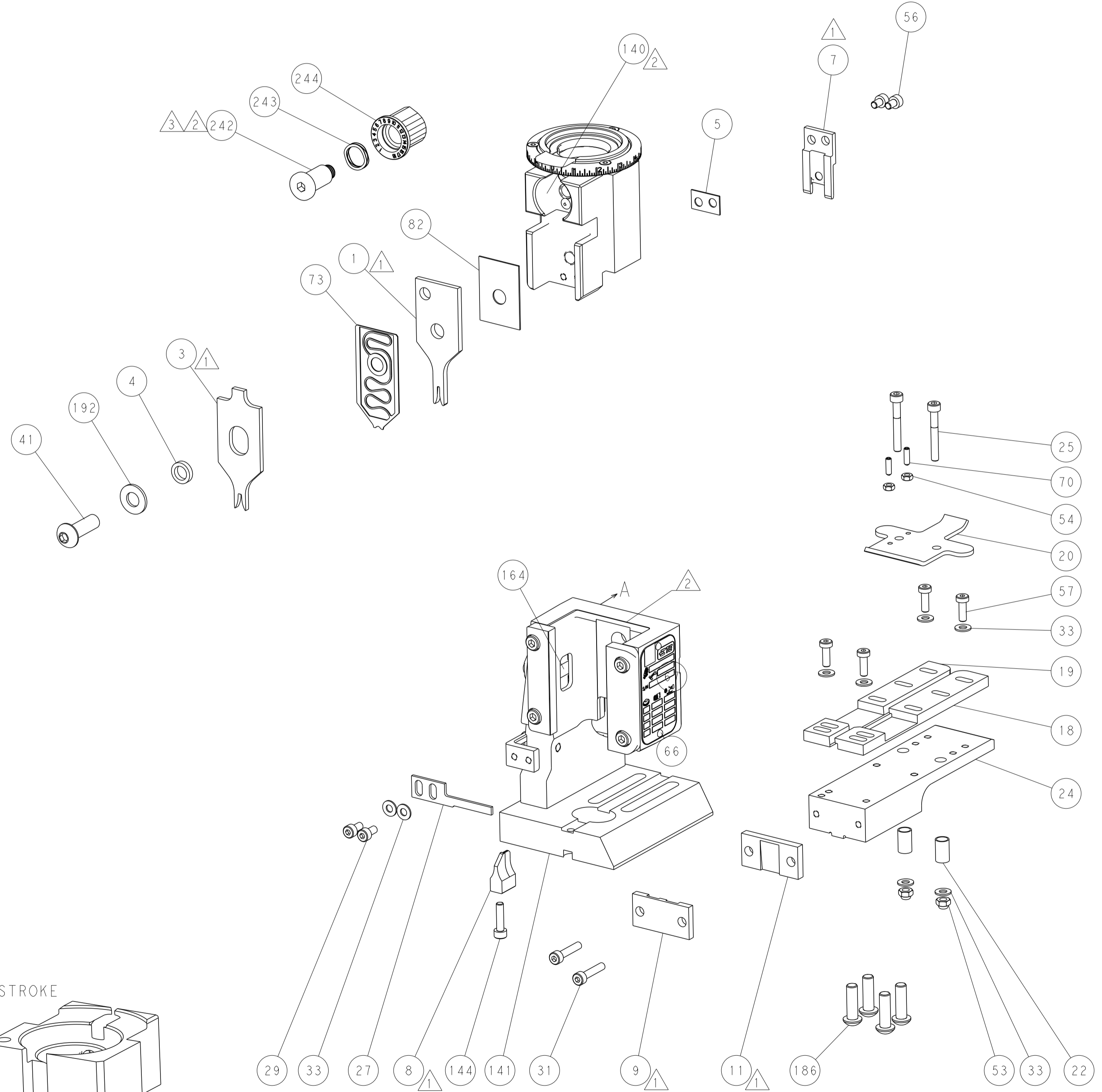

CAM POSITIONS

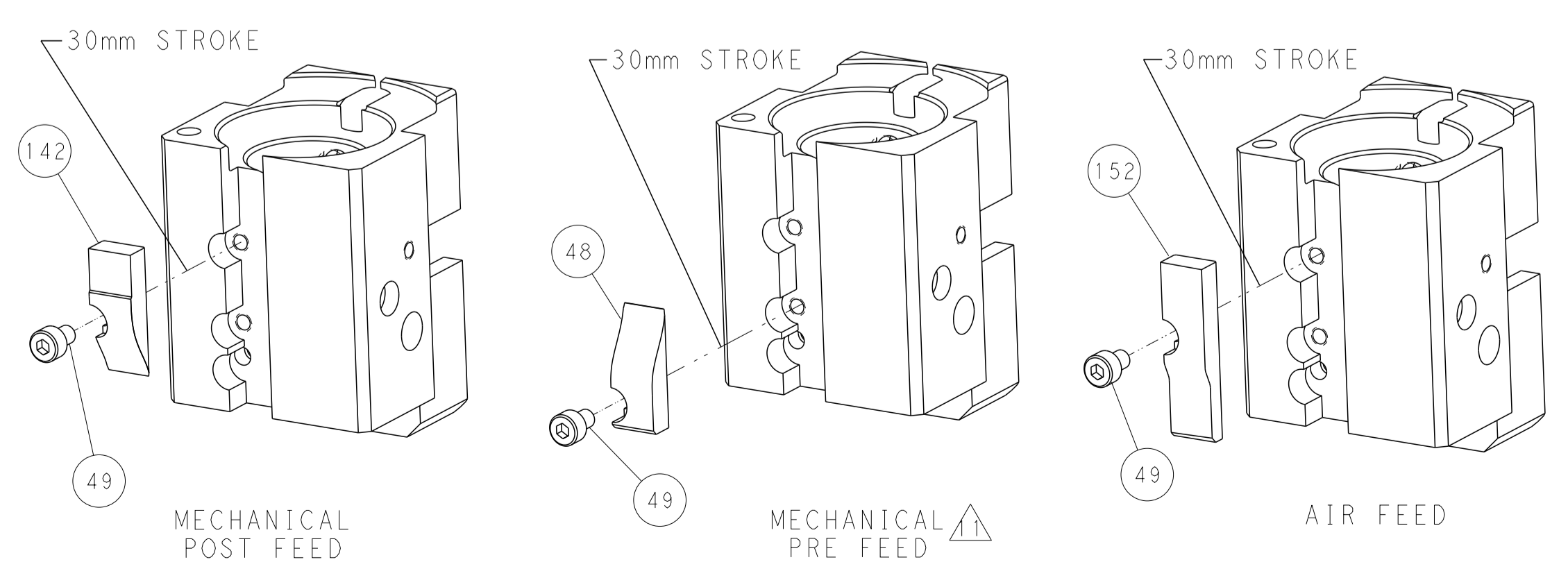

PACIFIC VERSION
 Shown on sheets 3 of 4 & 4 of 4
 (Atlantic version shown on sheets 1 of 4 & 2 of 4)

<small>THIS DRAWING IS UNPUBLISHED. RELEASED FOR PUBLICATION BY TYCO ELECTRONICS CORPORATION. ALL RIGHTS RESERVED.</small>		DWN: R. KNEPPER 13DEC2012 CHK: T. ELBIN 13DEC2012 APVD: M. CLIFFORD 13DEC2012	NAME: STE TE Connectivity Harrisburg, PA 17105-3608
DIMENSIONS: mm TOLERANCES UNLESS OTHERWISE SPECIFIED: 0 PLC ± 1 PLC ± 2 PLC ± 3 PLC ± 4 PLC ± ANGLES ± MATERIAL: - FINISH: -	PRODUCT SPEC: - APPLICATION SPEC: - WEIGHT: - SCALE: 1:1	SIZE: A1 CAGE CODE: 00779 DRAWING NO: C-2150288 SHEET 4 OF 4	RESTRICTED TO: - REV: B1