

- 1 HOUSING: BLACK NYLON OR POLYESTER, FLAME RETARDANT, UL 94V-0 RATED, GLASS FILLED  
 CONTACTS: BRASS  
 SHELLS: CARBON STEEL  
 EYELETS: BRASS
- 2 GOLD FLASH ON THE MATING SURFACES, 2.54µm[.000100] MIN TIN OR TIN-LEAD PLATE ON THE SOLDER END, 1.27µm[.000050] MIN NICKEL UNDERPLATE ON THE ENTIRE CONTACT.
- 3 0.76µm[.000030] MIN GOLD PLATE ON THE MATING SURFACES, 2.54µm[.000100] MIN TIN OR TIN-LEAD PLATE ON THE SOLDER END, 1.27µm[.000050] MIN NICKEL UNDERPLATE ON THE ENTIRE CONTACT  
 -OR-  
 GOLD FLASH OVER PALLADIUM-NICKEL PLATE, 0.76µm[.000030] MIN TOTAL ON THE MATING SURFACES, 2.54µm[.000100] MIN TIN OR TIN-LEAD PLATE ON THE SOLDER END, 1.27µm[.000050] MIN NICKEL UNDERPLATE ON THE ENTIRE CONTACT.
- 4 SHELLS: 2.54µm[.000100] MIN TIN OVER 1.27µm[.000050] MIN COPPER.  
 EYELETS: 5.08µm[.000200] MIN TIN OVER COPPER FLASH.  
 CONTACTS: SEE TABLE.  
 SCREWLOCKS AND INSERTS: CLEAR CHROMATE.
- 5 SCREWLOCKS FOR 1-747238-3 ASSEMBLY WILL BE BULK PACKED AND SHIPPED WITH ASSEMBLIES.
- 6 OBSOLETE PART NUMBER.
- 7 SUPERSEDED BY 1-747238-2.
- 8 SUPERSEDED BY 747238-6.
- 9 SUPERSEDED BY 747238-3.

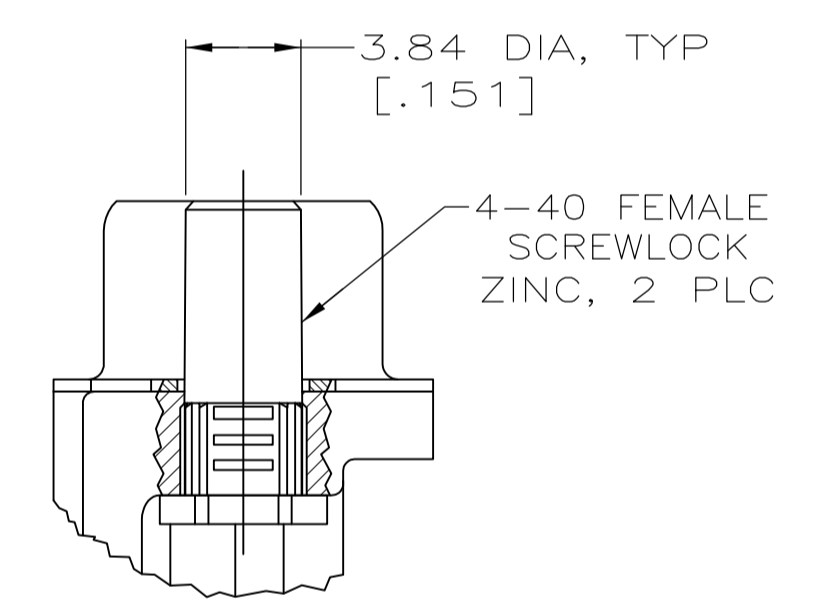

DETAIL D

DETAIL E

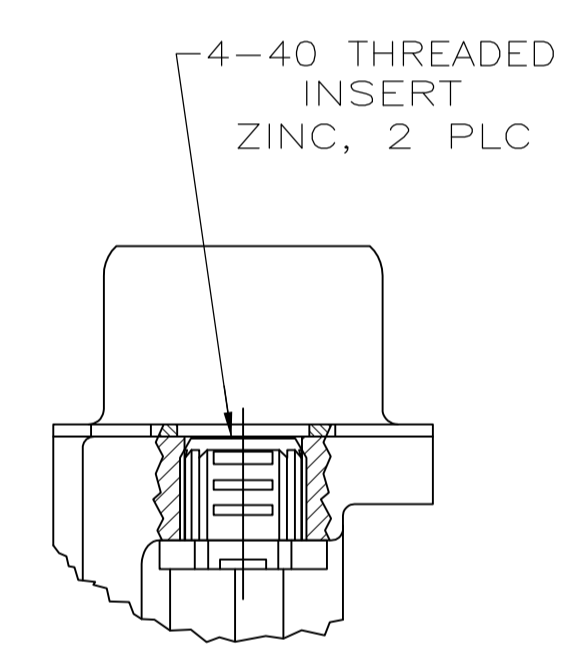
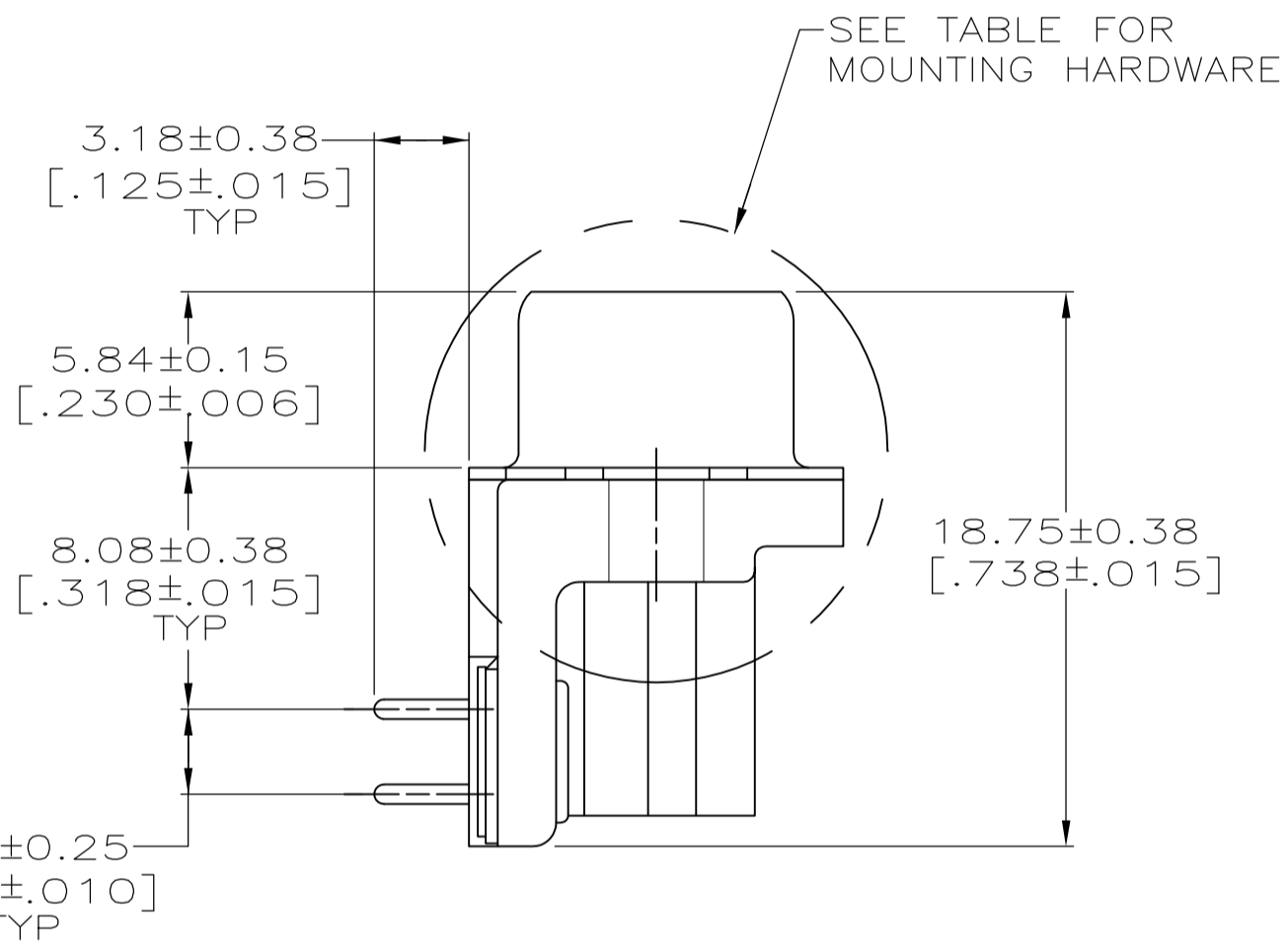
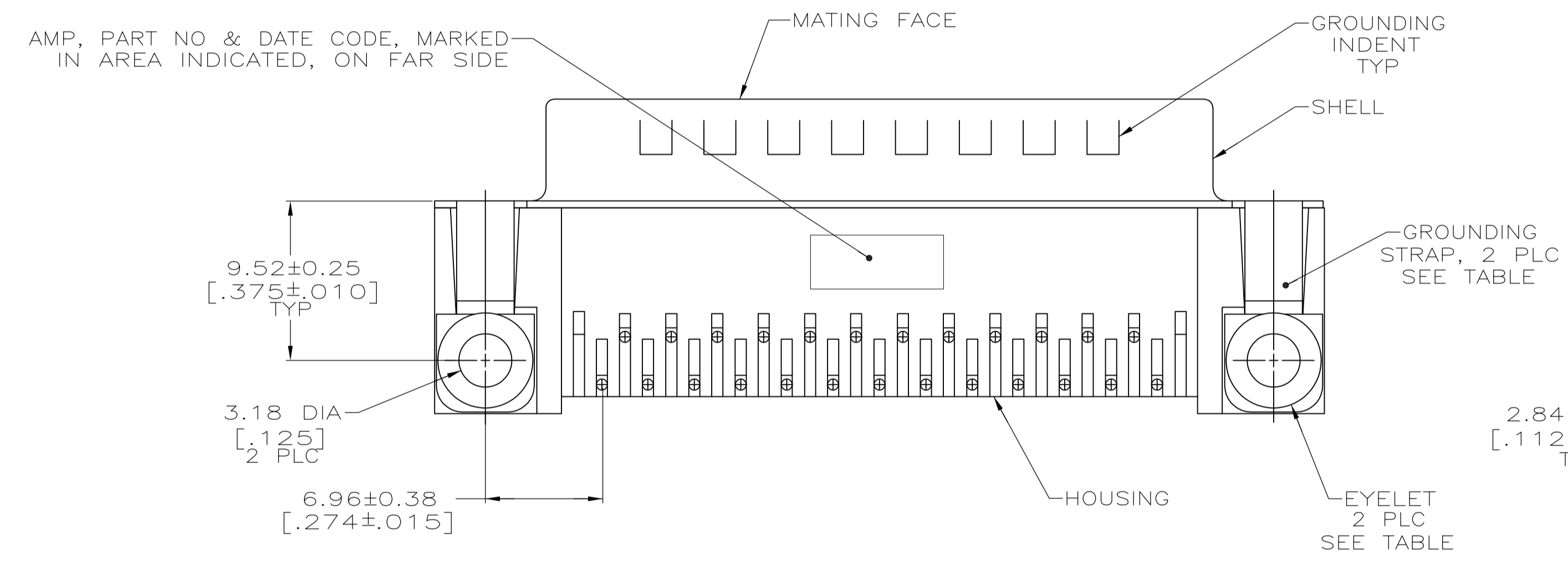
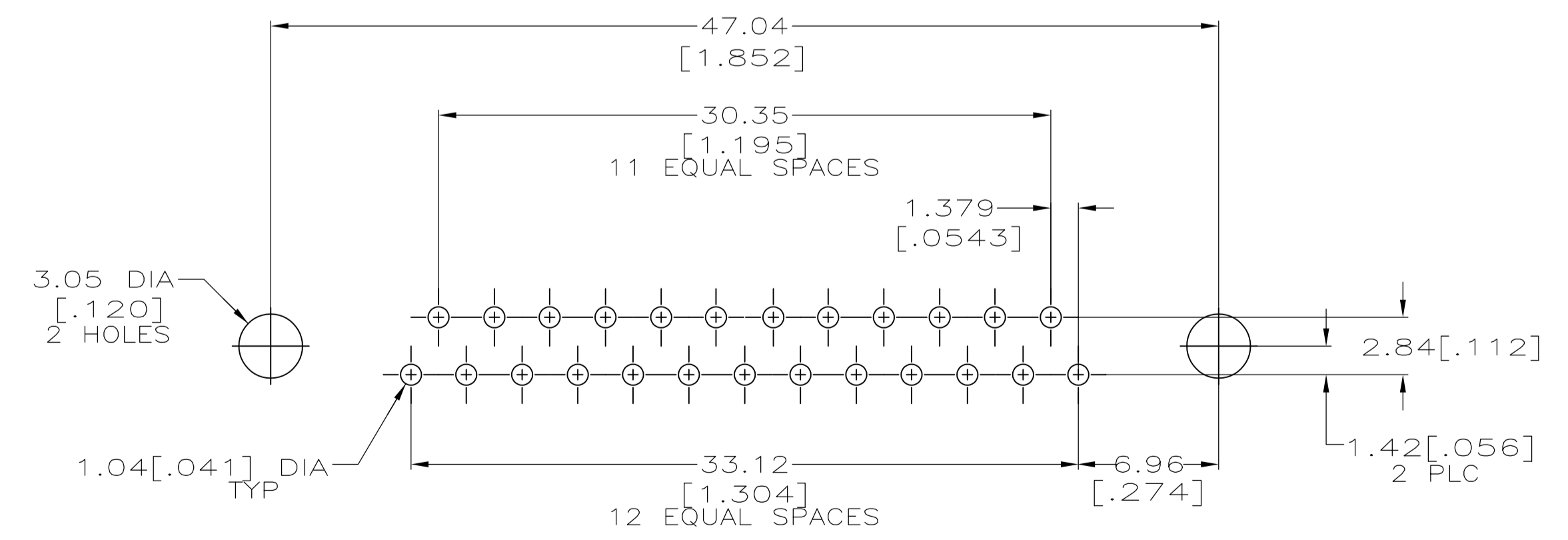
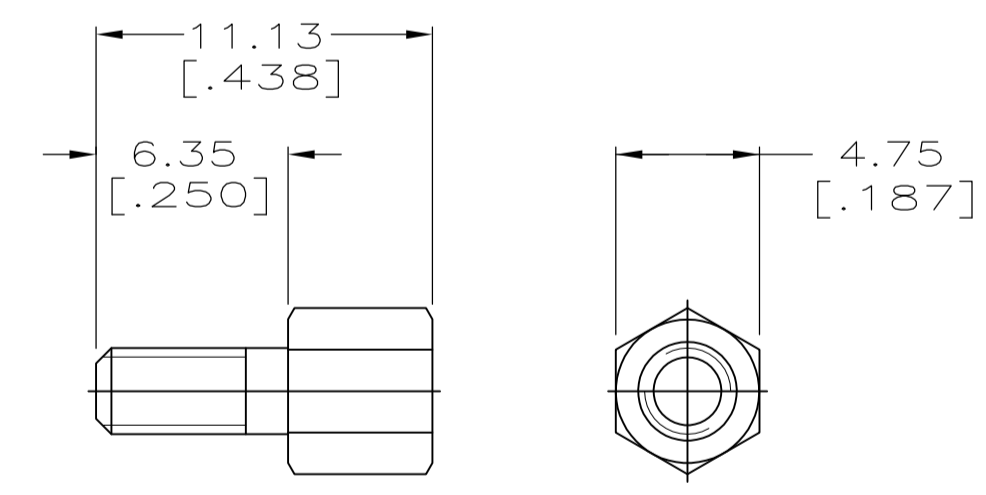
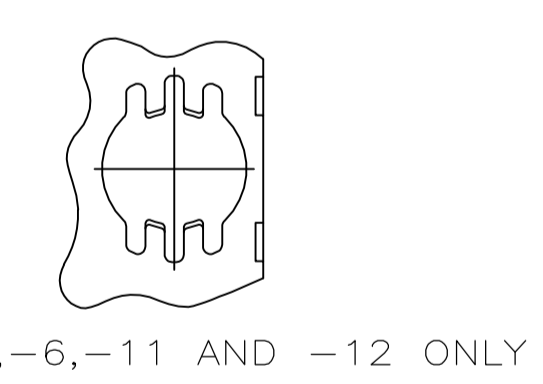

RECOMMENDED P.C. BOARD MOUNTING DIMENSIONS

NO SEE DETAIL B	NO	SEE DETAILS D AND F	1-747238-3
		SEE DETAIL E	1-747238-2
		SEE DETAIL D	1-747238-1
		-	1-747238-0
YES YES	YES	-	747238-9
		-	747238-8
		SEE DETAIL E	747238-7
		SEE DETAIL D	747238-6
GROUNDING STRAPS	EYELETS	MOUNTING HARDWARE	747238-5
			747238-4
			747238-3
			747238-2
CONTACT FINISH	PART NUMBER	-	747238-1
		-	747238-1
		-	747238-1
		-	747238-1

THIS DRAWING IS A CONTROLLED DOCUMENT. DIMENSIONING AND TOLERANCING PER ASME Y14.5M-2009

DIMENSIONS: mm [INCHES]	TOLERANCES UNLESS OTHERWISE SPECIFIED:	DIN W.G. LENKER 07-NOV-89	TE Connectivity
0 PLC ± -	1 PLC ± -	05-FEB-90	
2 PLC ± -	3 PLC ± 0.13[.005]	R. STONE	
4 PLC ± -	ANGLES ± 2°	M.D. GALLOWAY 06-FEB-90	
MATERIAL	FINISH	APVD NAME	PRODUCT SPEC
		108-40025	PLUG ASSEMBLY, SIZE 3, 25 POSITION, RIGHT ANGLE, FRONT METAL SHELL, .318 SERIES, AMPLIMITE® HD-20
		APPLICATION SPEC	RESTRICTED TO
		114-40010	SIZE CADE CODE DRAWING NO
		WEIGHT	A1 00779 747238
		CUSTOMER DRAWING	SCALE 4:1 SHEET 1 OF 1 REV AA