

POSITIONS/ CONTACTS	A		B	
	INCH	MM	INCH	MM
02/02	0.079	2.00	0.173	4.40
03/03	0.157	4.00	0.252	6.40
04/04	0.236	6.00	0.331	8.40
05/05	0.315	8.00	0.409	10.40
06/06	0.394	10.00	0.488	12.40
07/07	0.472	12.00	0.567	14.40
08/08	0.551	14.00	0.646	16.40
09/09	0.630	16.00	0.724	18.40
10/10	0.709	18.00	0.803	20.40
11/11	0.787	20.00	0.882	22.40
12/12	0.866	22.00	0.961	24.40
13/13	0.945	24.00	1.039	26.40
14/14	1.024	26.00	1.118	28.40
15/15	1.102	28.00	1.197	30.40
16/16	1.181	30.00	1.276	32.40
17/17	1.260	32.00	1.354	34.40
18/18	1.339	34.00	1.433	36.40
19/19	1.417	36.00	1.512	38.40
20/20	1.496	38.00	1.591	40.40
21/21	1.575	40.00	1.669	42.40
22/22	1.654	42.00	1.748	44.40
23/23	1.732	44.00	1.827	46.40
24/24	1.811	46.00	1.906	48.40
25/25	1.890	48.00	1.984	50.40
26/26	1.969	50.00	2.063	52.40
27/27	2.047	52.00	2.142	54.40
28/28	2.126	54.00	2.220	56.40
29/29	2.205	56.00	2.299	58.40
30/30	2.283	58.00	2.378	60.40
31**/31	2.362	60.00	2.457	62.40
32**/32	2.441	62.00	2.535	64.40
33**/33	2.520	64.00	2.614	66.40
34**/34	2.598	66.00	2.693	68.40
35**/35	2.677	68.00	2.772	70.40
36**/36	2.756	70.00	2.850	72.40
37**/37	2.835	72.00	2.929	74.40
38**/38	2.913	74.00	3.008	76.40
39**/39	2.992	76.00	3.087	78.40
40**/40	3.071	78.00	3.165	80.40

**CONSULT FACTORY FOR POSITION 31 THRU 40.

NOTES:

1. INSULATOR MATERIAL: SEE PART NUMBER CODING.
2. CONTACT MATERIAL: PHOSPHOR BRONZE.
3. CONTACT PLATING: .000030"-.000050" MIN NICKEL UNDERPLATE, GOLD FLASH OVERALL.
4. CURRENT RATING: 2 AMP.
5. INSULATOR RESISTANCE: 5000 MEGOHMS MIN.
6. CONTACT RESISTANCE: 20 MILLIOHMS MAX.
7. DIELECTRIC WITHSTANDING: AC 500V.
8. OPERATING TEMPERATURE: -40° C TO +105° C.
9. *PROCESSING TEMP.: WAVE/MANUAL SOLDERING ONLY.
10. MATES WITH SULLINS .079 [2.00] CONTACT CENTER MALE HEADER SERIES. (.020 [0.50] SQUARE POSTS)

PART NUMBER CODING

NPPNxx1FGGN-RC

NUMBER OF POSITIONS

(CONTACTS PER ROW, 02 THRU 40)

INSULATOR MATERIAL

N = NYLON 6T, UL 94V-0.

P = OBSOLETE, REPLACE WITH N

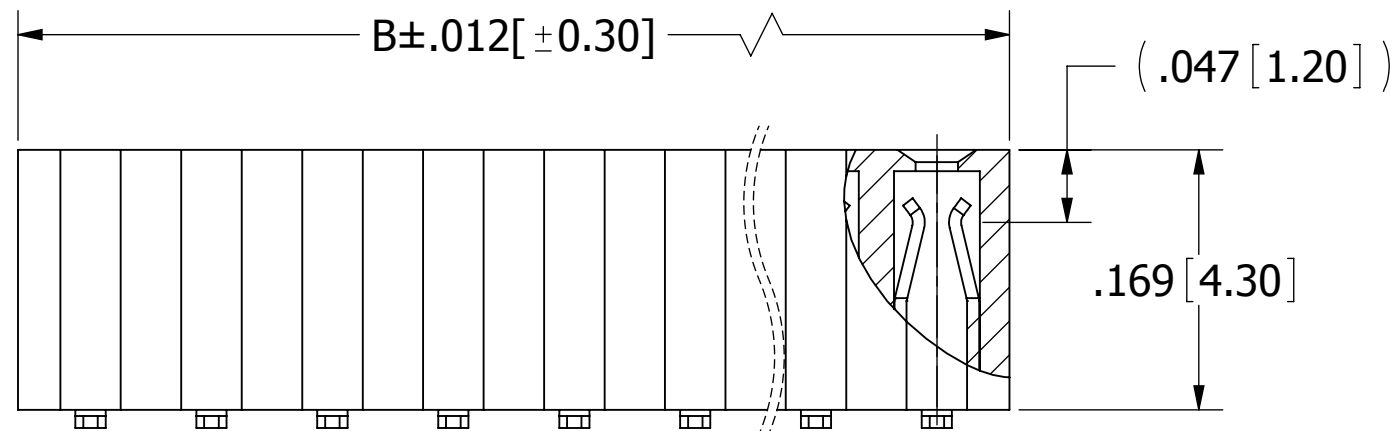
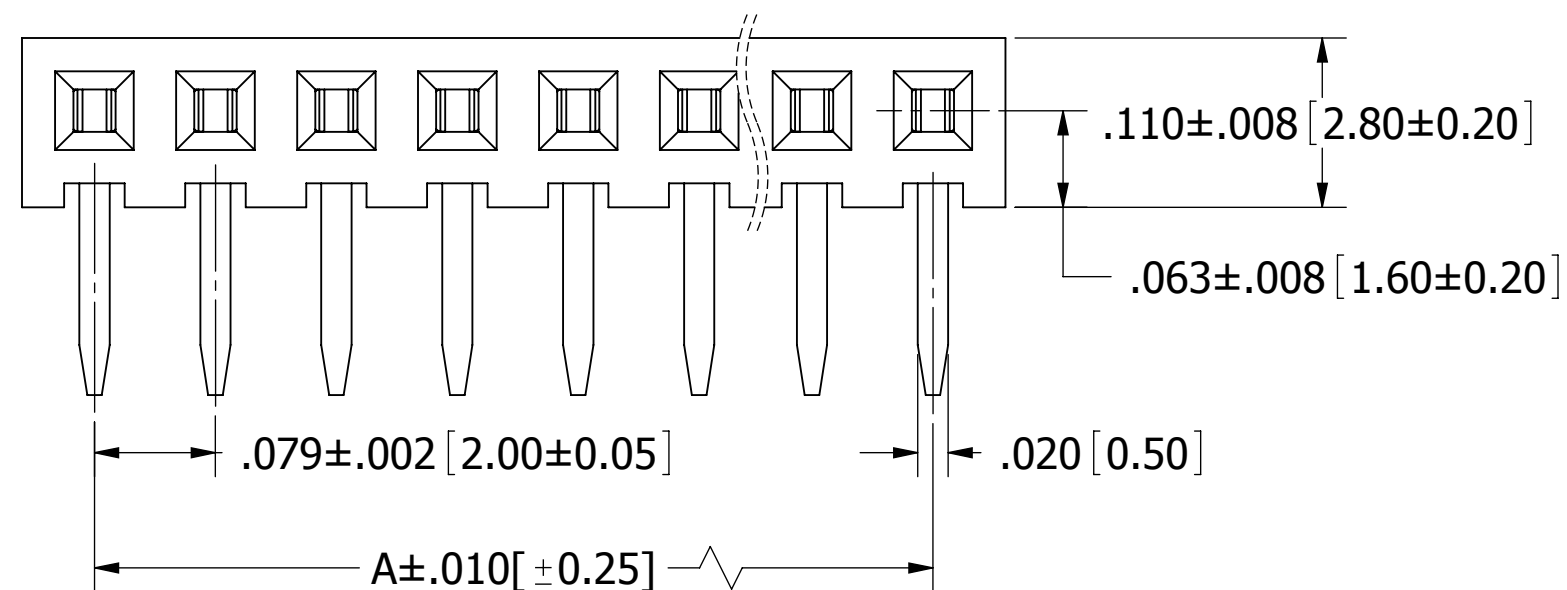

02-20, 0.20mm MAX.
21-35, 0.30mm MAX.
36-40, 0.40mm MAX.

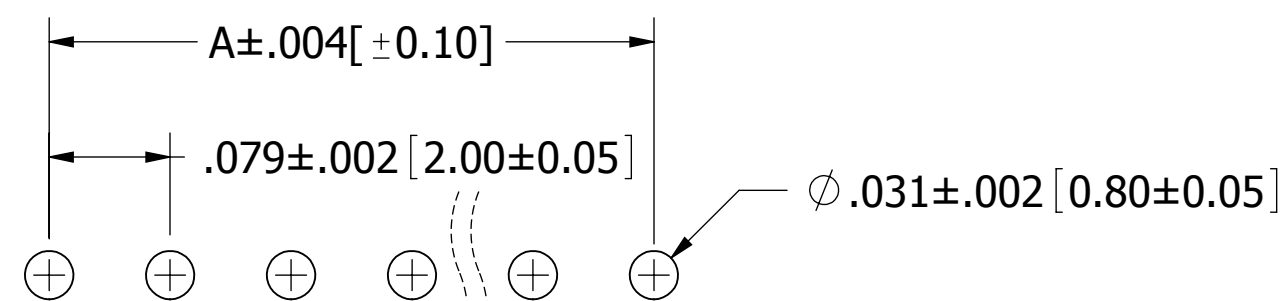

RECOMMENDED PCB LAYOUT

REVISIONS				
REV.	ECO. NO	DESCRIPTION	DATE	BY
D	2515	ADD NOTE 10 MATING PARTS.	01/16/2012	LH
E	3120	UPDATE PROCESSING TEMPERATURE FOR NYLON 6T MATERIAL AND CURRENT RATING TO 2 AMPS (WAS 1 AMP), UPDATE STRAIGHTNESS TOL	04/15/2015	LH

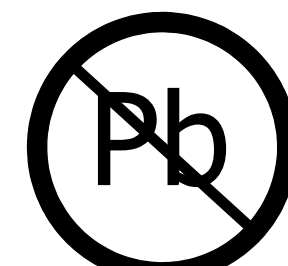
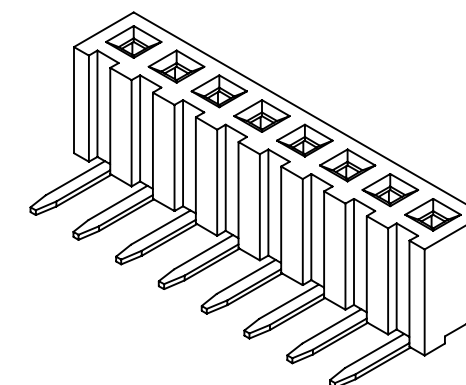

RoHS COMPLIANT

UNLESS OTHERWISE SPECIFIED: DIMENSIONS ARE IN INCHES [MM]		DRAWN	DATE	NAME	
TOLERANCES:			03/23/2009	JH	
ANGULAR: ± 5°		<small>THE INFORMATION HEREIN CONTAINS PROPRIETARY INFORMATION OF SULLINS ELECTRONICS AND IS NOT TO BE REPRODUCED, USED OR DISCLOSED TO OTHERS FOR ANY PURPOSE EXCEPT AS SPECIFICALLY AUTHORIZED IN WRITING BY AN OFFICER OF SULLINS ELECTRONICS.</small>			TITLE
DECIMALS		<small>SCALE: 4:1</small>			HEADER FEMALE, 2mm CC, 1 ROW, RA
.X=± .012 [.30]		<small>SHEET 1 OF 1</small>			PART NUMBER
.XX=± .008 [.20]		SIZE	CAGE CODE	DWG. NO.	NPPNxx1FGGN-RC
.XXX=± .006 [.15]		C	54453	10490	REV
					E