

THIS DRAWING IS UNPUBLISHED. RELEASED FOR PUBLICATION
 © COPYRIGHT BY TYCO ELECTRONICS CORPORATION. ALL RIGHTS RESERVED.

LOC	DIST	REVISIONS			
P	LTR	DESCRIPTION	DATE	DWN	APVD
AF	50	F2	REVISED PER ECR-07-018788	20AUG07	HMR GP

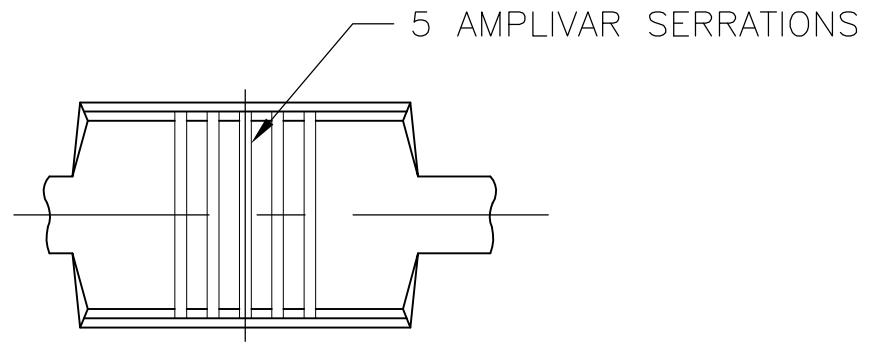

- CONTINUOUS STRIP ON REELS.
- DIMENSIONS IN BRACKETS ARE IN INCHES.
- FOR ADDITIONAL INFORMATION, SEE APPLICATION SPEC. 114-2008.
- WIRE RANGE: 1500-5000 CMA.
- CRIMP WIDTH: .110 F TYPE (AMPLIVAR THRU)
 CRIMP HEIGHT (±.002)=(TOTAL CMA+10,700)/193,400
 GENERAL APPLICATION GUIDELINES MUST BE FOLLOWED AS SPECIFIED IN CATALOG #82221
 FOR APPLICATOR INFORMATION CALL:1-800-722-1111
 FOR PRODUCT INFORMATION CALL:1-800-522-6752

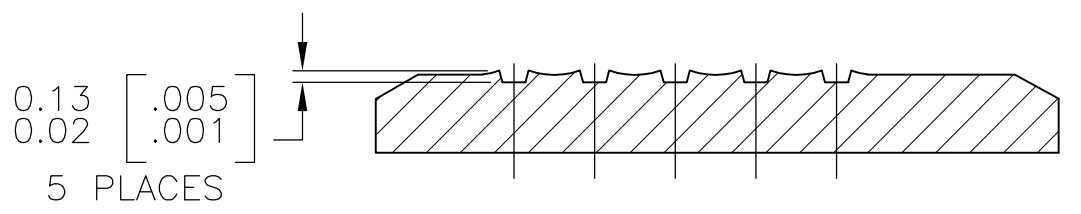
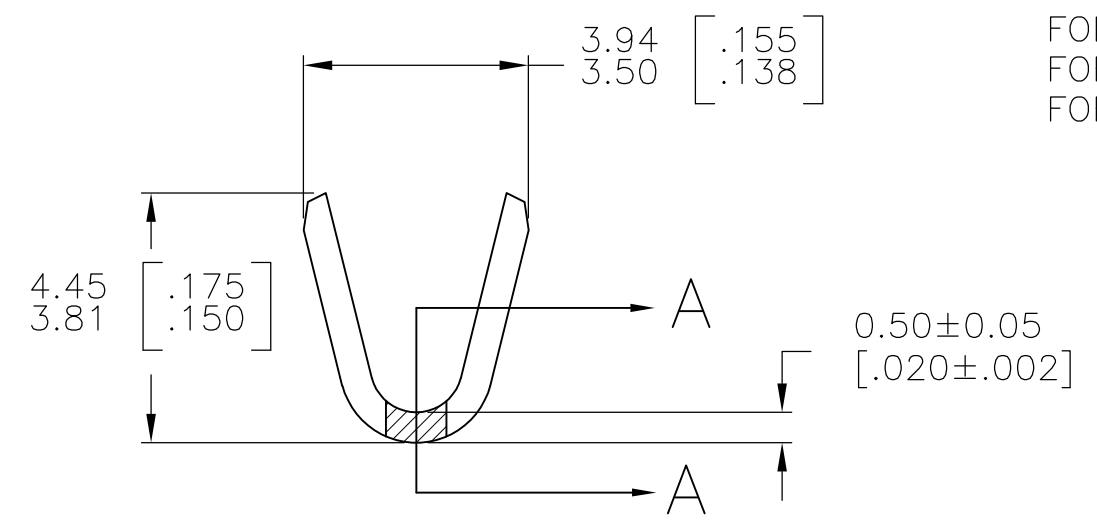
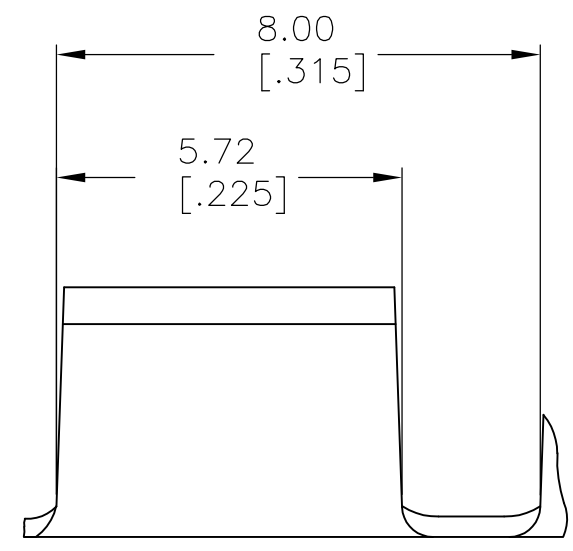

SECTION A-A
 SCALE 20:1

OBSOLETE	TIN PLATE	PH BRZ	42776-4
OBSOLETE	-	PH BRZ	42776-3
OBSOLETE	TIN PLATE	BRASS	42776-2
	-	BRASS	42776-1
	FINISH	MATERIAL	PART NO

THIS DRAWING IS A CONTROLLED DOCUMENT.		DWN RAGHAVENDRA 05JUL06	Tyco Electronics Corporation Harrisburg, PA 17105-3608	
DIMENSIONS: mm [INCHES]		CHK G.D.PORTA 05JUL06	NAME	
TOLERANCES UNLESS OTHERWISE SPECIFIED:		APVD G.D.PORTA 05JUL06	PRODUCT SPEC	
0 PLC ± -		APPLICATION SPEC		
1 PLC ± -		SIZE CAGE CODE DRAWING NO RESTRICTED TO		
2 PLC ± -		A3 00779 C-42776		
3 PLC ± 0.38 [.015]		SCALE 8:1 SHEET 1 OF 1 REV F2		
4 PLC ± -		CUSTOMER DRAWING		
ANGLES ± 1° 0'				
MATERIAL SEE TABLE	FINISH SEE TABLE			