

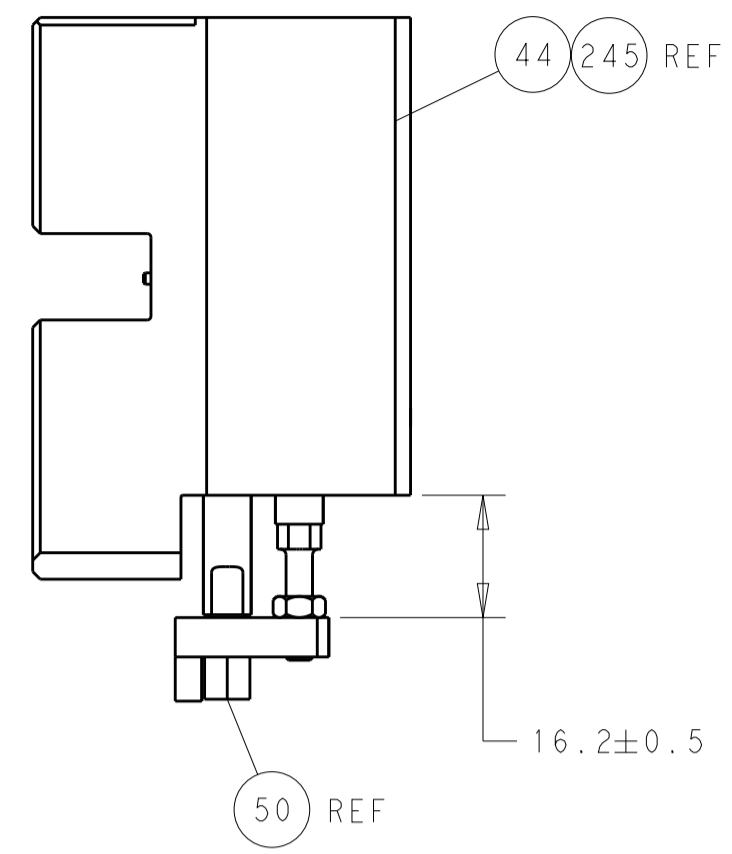

LOC	DIST	REV	DATE	BY	APPV
A	66				
REVISIONS			DESCRIPTION	DATE	BY
			SEE SHEET 1		



HOLDDOWN SET-UP

FEED TYPE  
MECHANICAL

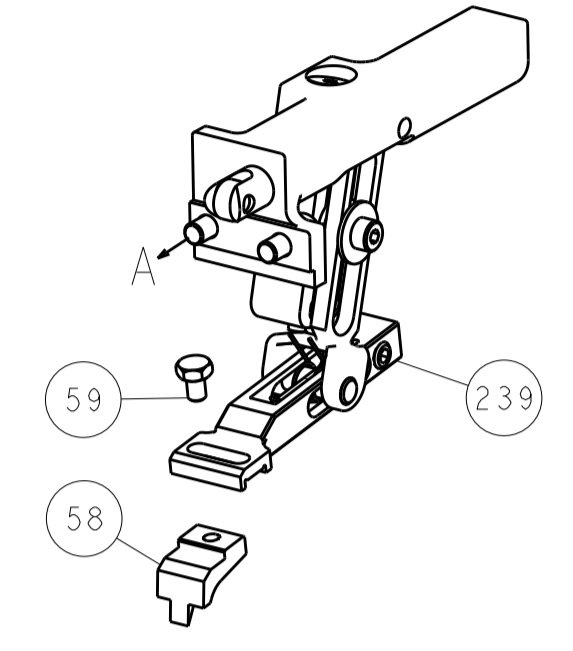

PNEUMATIC

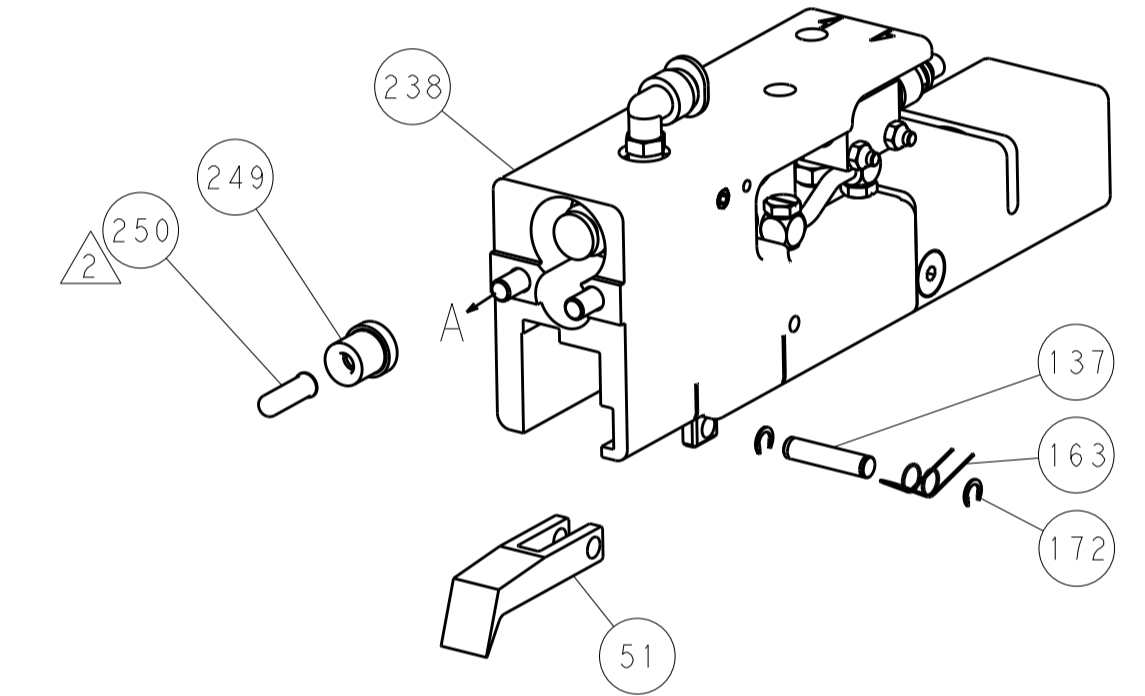

SERVO  
LATCH PLATE

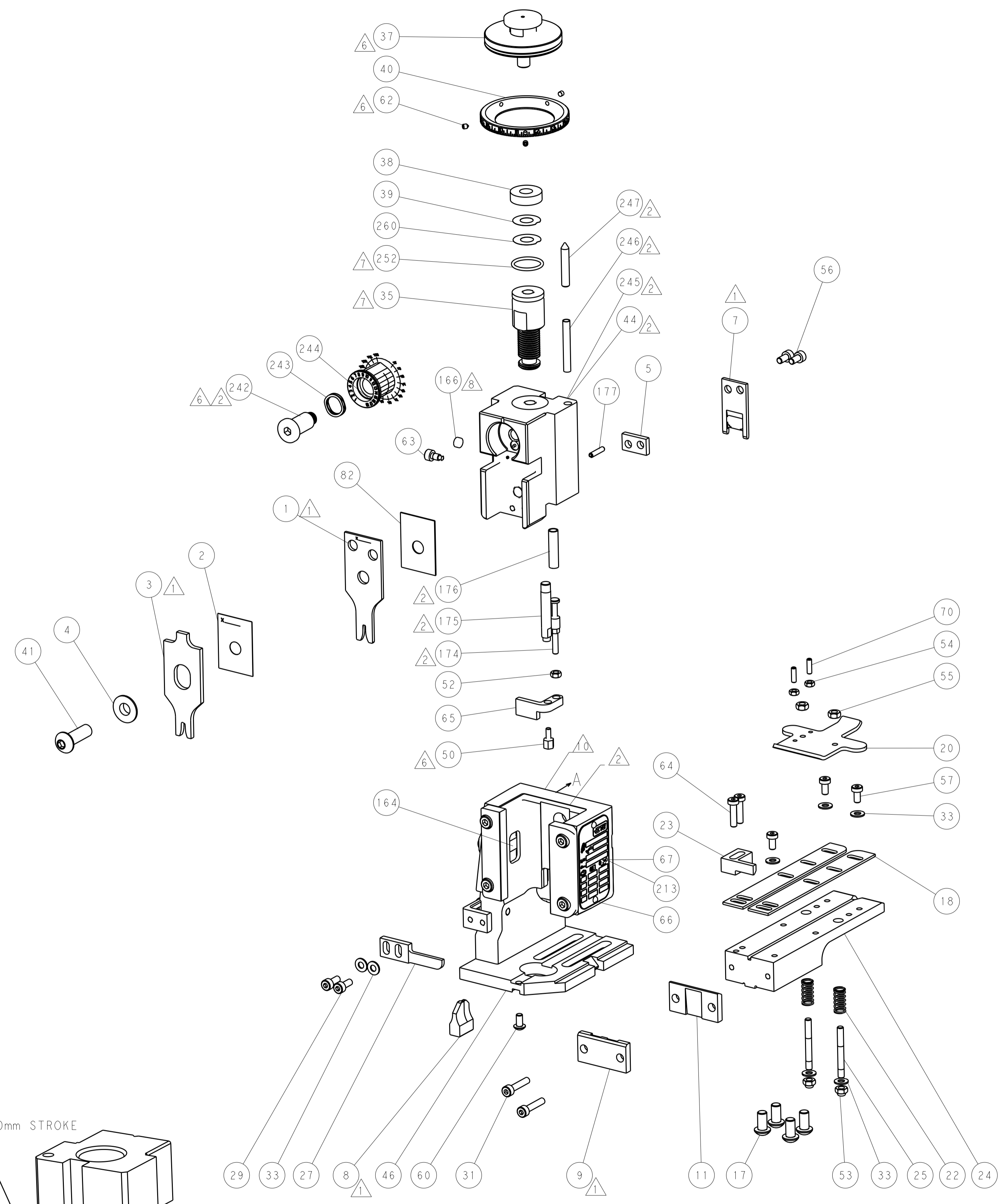
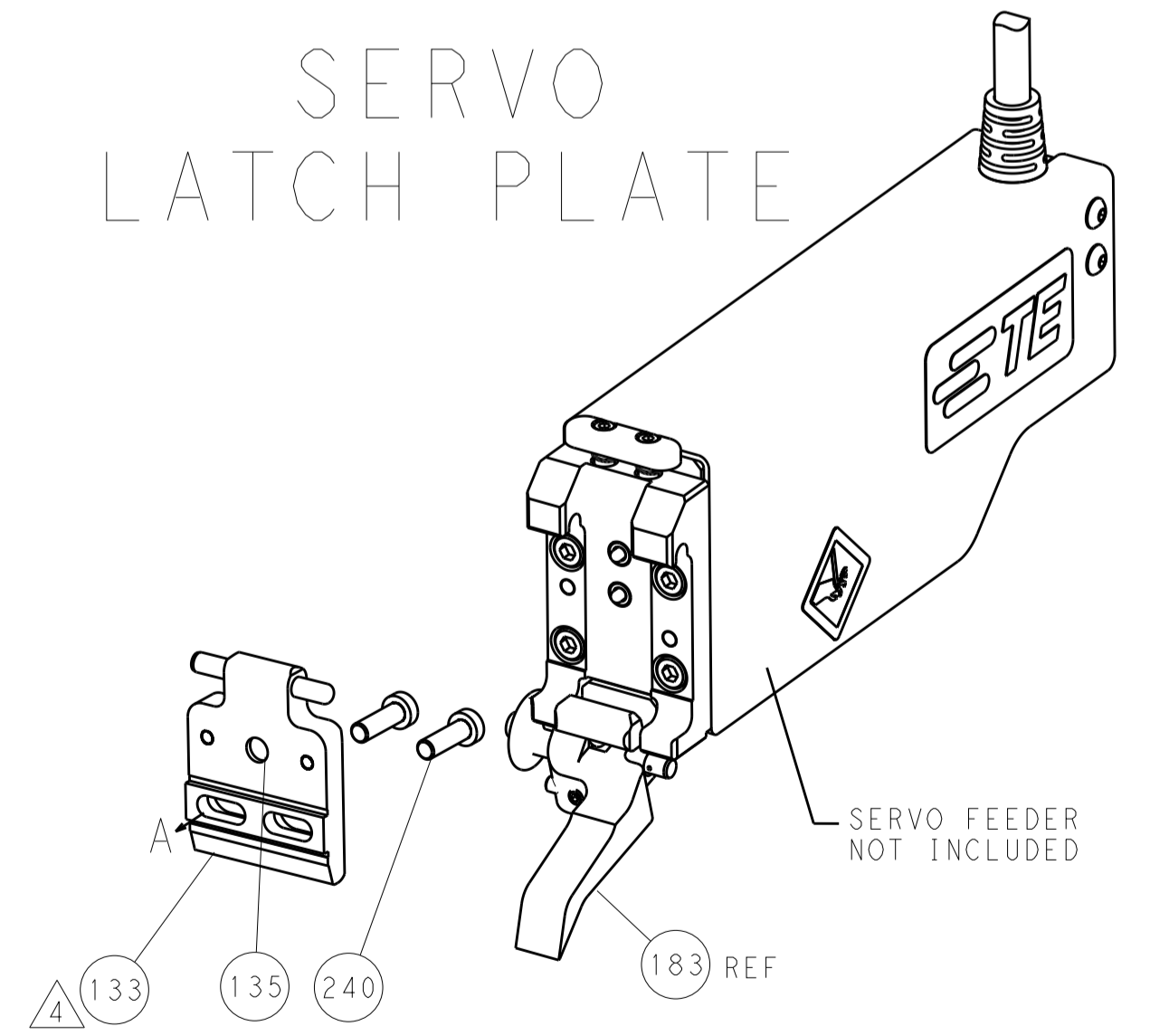

CAM POSITIONS

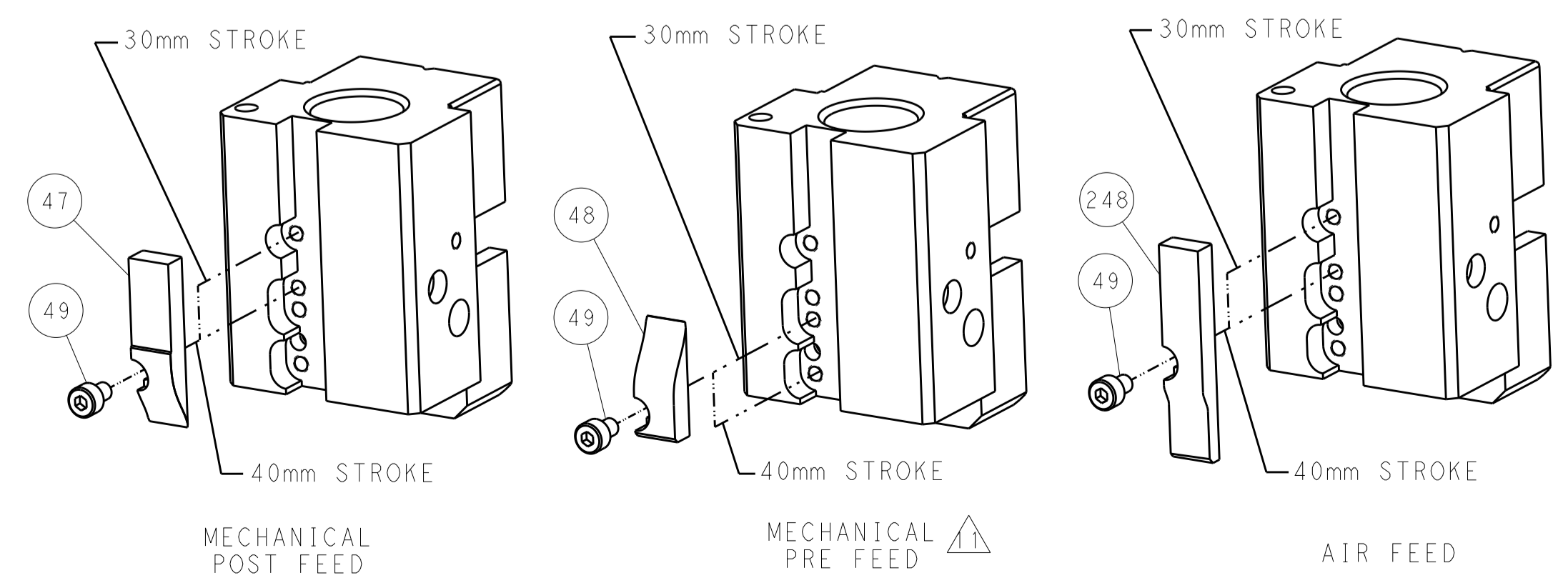

ATLANTIC VERSION  
 Shown on sheets 1 of 4 & 2 of 4  
 (Pacific version shown on sheets 3 of 4 & 4 of 4)

DIMENSIONS:		TOLERANCES UNLESS OTHERWISE SPECIFIED:		DWG: K. STANEM 4MARCH2013		TE Connectivity	
mm	0 PLC	±		CHK: G. BAILEY 4MARCH2013	NAME	Harrisburg, PA 17105-3608	
	1 PLC	±		APPV: T. ERLIN 4MARCH2013	PRODUCT SPEC	Ocean End Feed	
	2 PLC	±			APPLICATION SPEC	Applicator	
	3 PLC	±			SIZE	CAGE CODE	DRAWING NO.
	4 PLC	±			WEIGHT	A11 00779	©=2150210
	ANGLES	±			Customer Accessible Production Drawing		
MATERIAL:	FINISH:				SCALE	1:1	SHEET 2 OF 4



LOC		DIST		REVISIONS			
A	66	P	LTM	DESCRIPTION	DATE	OWN	APVD
		-	-	SEE SHEET 1	-	-	-

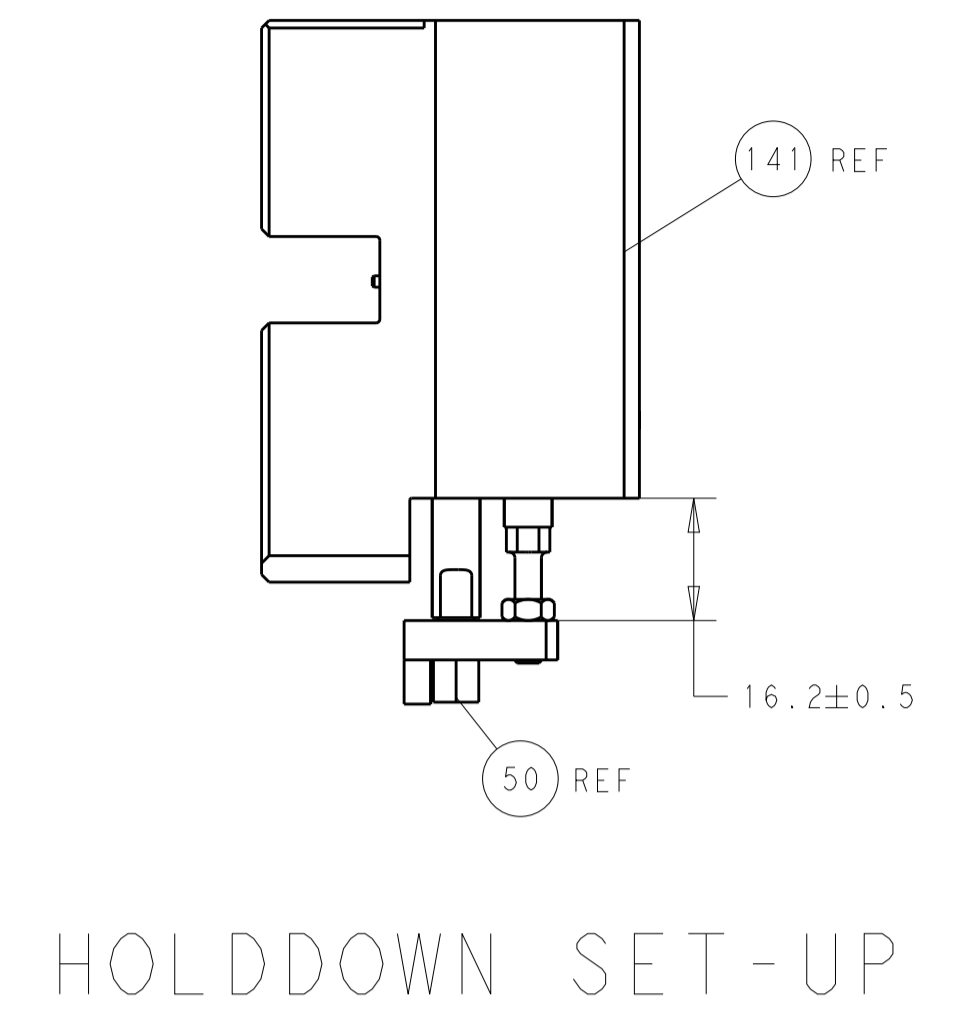

FEED TYPE  
MECHANICAL

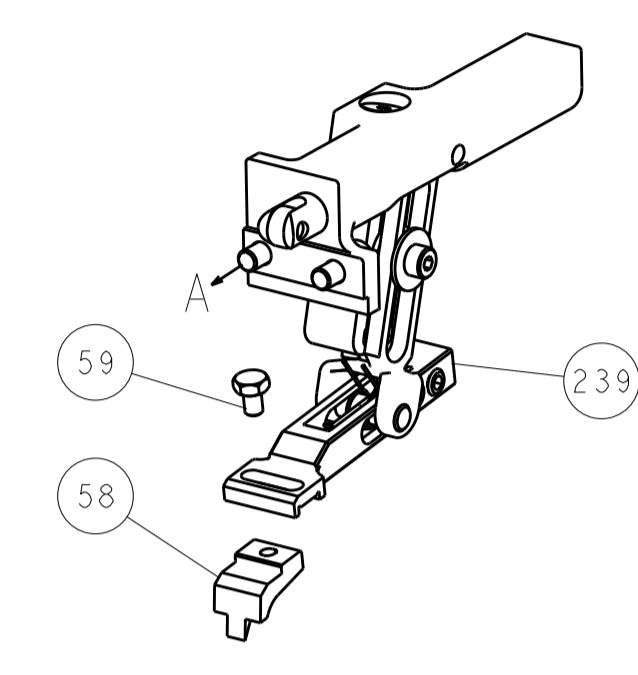

PNEUMATIC

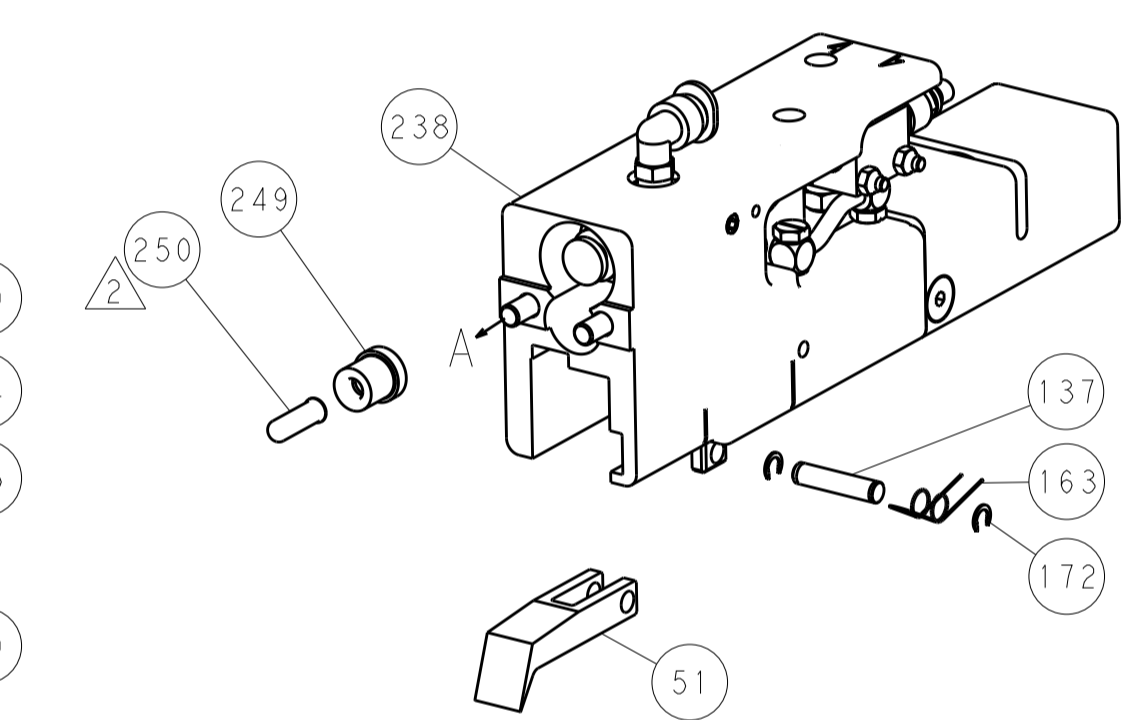

SERVO LATCH PLATE

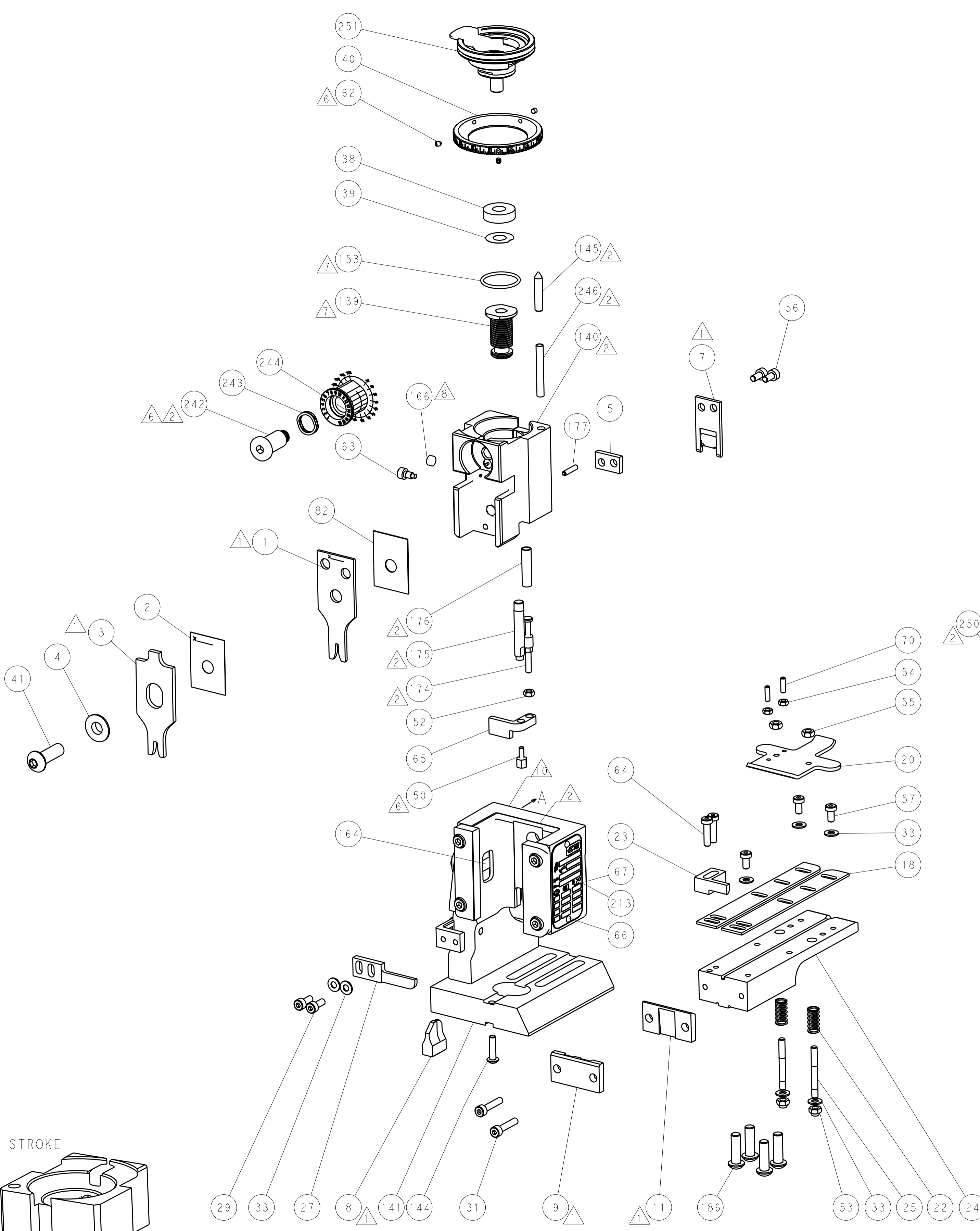
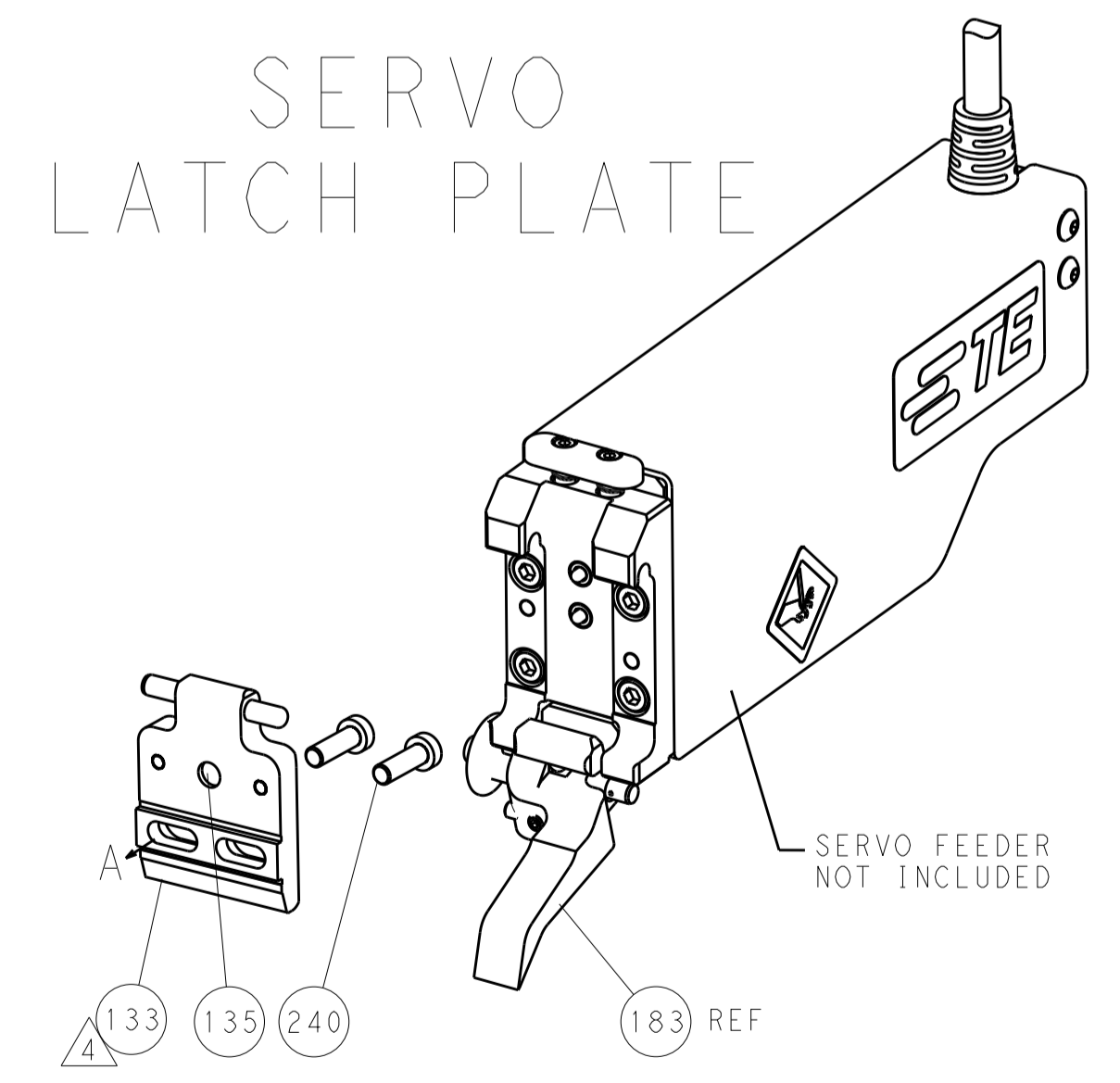

CAM POSITIONS

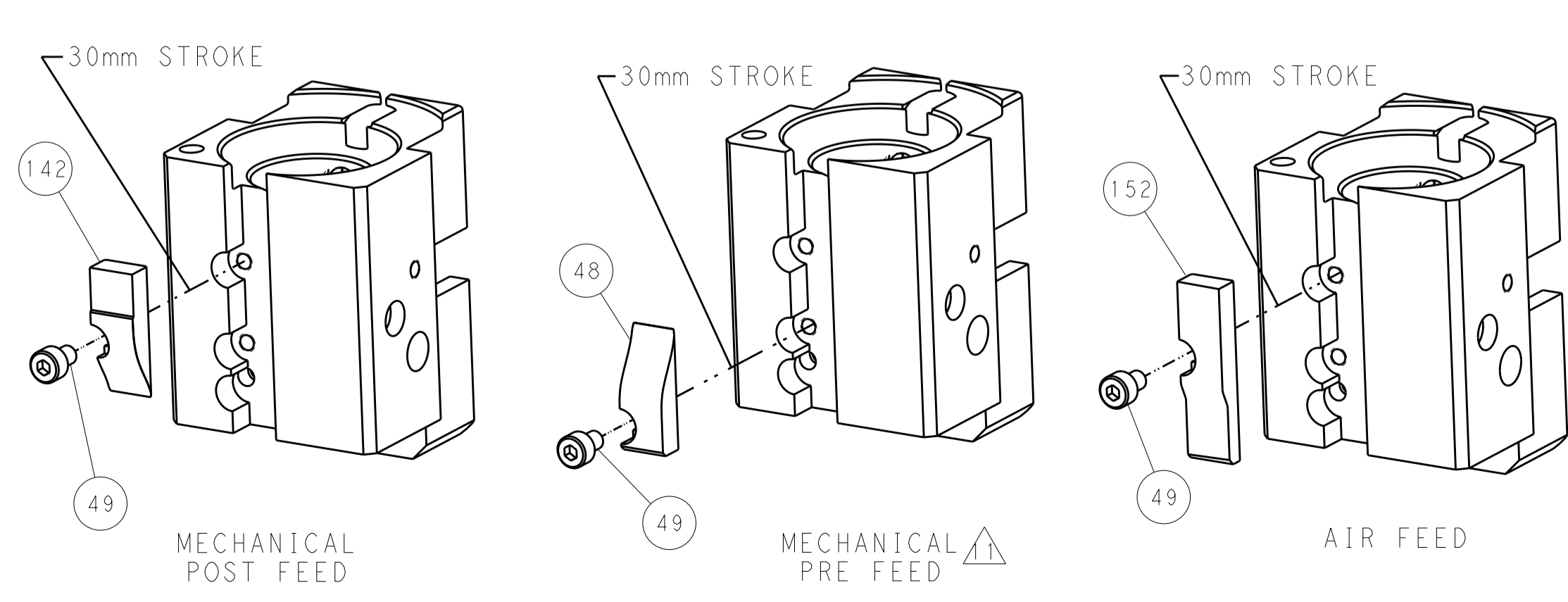

PACIFIC VERSION  
 Shown on sheets 3 of 4 & 4 of 4  
 (Atlantic version shown on sheets 1 of 4 & 2 of 4)

DIMENSIONS:		TOLERANCES UNLESS OTHERWISE SPECIFIED:		DWN: STAKEM 4MARCH2013		TE Connectivity	
mm	0 PLC	±		CHK: G. BAILEY 4MARCH2013	NAME	Harrisburg, PA 17105-3608	
	1 PLC	±		APVD: T. ERLIN 4MARCH2013	PRODUCT SPEC	Ocean End Feed Applicator	
	2 PLC	±		APPLICATION SPEC	SIZE	CAGE CODE	DRAWING NO.
	3 PLC	±		WEIGHT	A11	00779	2150210
	4 PLC	±		Customer Accessible Production Drawing	SCALE	1:1	SHEET 4 OF 4
MATERIAL	FINISH			RESTRICTED TO		REV B1	