

DAC701
DAC702
DAC703

Monolithic 16-Bit DIGITAL-TO-ANALOG CONVERTERS

FEATURES

- V_{OUT} AND I_{OUT} MODELS
- **HIGH ACCURACY:**
Linearity Error $\pm 0.0015\%$ of FSR max
Differential Linearity Error $\pm 0.003\%$ of FSR max
- **MONOTONIC (at 15 bits) OVER FULL SPECIFICATION TEMPERATURE RANGE**
- **PIN-COMPATIBLE WITH DAC70, DAC71, DAC72**
- **DUAL-IN-LINE PLASTIC AND HERMETIC CERAMIC AND SOIC**

DESCRIPTION

The DAC70X family comprise of complete 16-bit digital-to-analog converters that includes a precision buried-zener voltage reference and a low-noise, fast-settling output operational amplifier (voltage output models), all on one small monolithic chip. A combination of current-switch design techniques accomplishes not only 15-bit monotonicity over the entire specified temperature range, but also a maximum end-point linearity error of $\pm 0.0015\%$ of full-scale range. Total full-scale gain drift is limited to $\pm 10\text{ppm}/^\circ\text{C}$ maximum (LH and CH grades).

Digital inputs are complementary binary coded and are TTL-, LSTTL-, 54/74C- and 54/74HC-compatible over the entire temperature range. Outputs of 0 to +10V, $\pm 10\text{V}$, 0 to -2mA , and $\pm 1\text{mA}$ are available.

These D/A converters are packaged in hermetic 24-pin ceramic side-brazed or molded plastic. The DIP-packaged parts are pin-compatible with the voltage and current output DAC71 and DAC72 model families. The DAC702 is also pin-compatible with the DAC70 model family. In addition, the DAC703 is offered in a 24-pin SOIC package for surface mount applications.

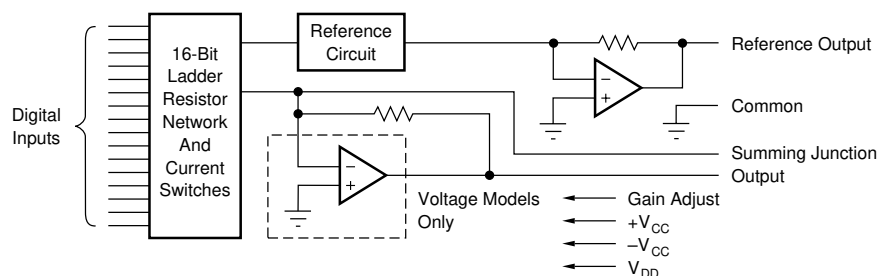

International Airport Industrial Park • Mailing Address: PO Box 11400, Tucson, AZ 85734 • Street Address: 6730 S. Tucson Blvd., Tucson, AZ 85706 • Tel: (520) 746-1111 • Twx: 910-952-1111
Internet: <http://www.burr-brown.com/> • FAXLine: (800) 548-6133 (US/Canada Only) • Cable: BBRCORP • Telex: 066-6491 • FAX: (520) 889-1510 • Immediate Product Info: (800) 548-6132

SPECIFICATIONS

At +25°C and rated power supplies, unless otherwise noted.

PARAMETER	DAC702/703J			DAC701/702/703K			DAC701/702/703B, S			DAC701/702/703L, C			UNITS
	MIN	TYP	MAX	MIN	TYP	MAX	MIN	TYP	MAX	MIN	TYP	MAX	
INPUT													
DIGITAL INPUT													
Resolution			16			*			*			*	Bits
Digital Inputs (1)													
V _{IH}	+2.4		+V _{CC}	*		*	*		*	*		*	V
V _{IL}	-1.0		+0.8	*		*	*		*	*		*	V
I _{IH} , V _I = +2.7V			+40			*			*	*		*	μA
I _{IL} , V _I = +0.4V		-0.35	-0.5		*	*		*	*	*		*	mA
TRANSFER CHARACTERISTICS													
ACCURACY (2)													
Linearity Error(4)		±0.0015	±0.006		*	±0.003		*	*		±0.00075	±0.0015	% of FSR(3)
Differential Linearity Error(4)		±0.003	±0.012		*	±0.006		*	*		±0.0015	±0.003	% of FSR
Differential Linearity Error at Bipolar Zero (DAC702/703)(4)					±0.003	±0.006		±0.0015	±0.003		*	*	% of FSR
Gain Error(5)		±0.07	±0.30		*	±0.15		±0.05	±0.10		*	*	%
Zero Error(5, 6)		±0.05	±0.10		*	*		*	*		*	*	% of FSR
Monotonicity Over Spec. Temp Range	13			14			*			15			Bits
DRIFT (over specification temperature range)													
Total Error Over Temperature Range (all models)(7)		±0.08			*	±0.15		±0.05	±0.10		*	*	% of FSR
Total Full Scale Drift: DAC701		±10			*	±30		±8.5	±18		±6	±13	ppm of FSR/°C
DAC702/703		±10			*	±25		±7	±15		*	*	ppm of FSR/°C
Gain Drift (all models)		±10	±30		*	±25		±7	±15		±5	±10	ppm/°C
Zero Drift: DAC701					±2.5	±5		±1.5	±3		*	*	ppm of FSR/°C
DAC702/703		±5	±15		*	±12		±4	±10		±2.5	±5	ppm of FSR/°C
Differential Linearity Over Temp.(4)			±0.012			+0.009, -0.006			*			+0.006, -0.003	% of FSR
Linearity Error Over Temp.(4)			±0.012			±0.006			*			±0.003	% of FSR
SETTLING TIME (to ±0.003% of FSR)(8)													
DAC701/703 (V _{OUT} Models) Full Scale Step, 2kΩ Load		4			*	8		*	*		*	*	μs
1LSB Step at Worst-Case Code(9)		2.5			*			*			*		μs
Slew Rate		10			*			*			*		V/μs
DAC702 (I _{OUT} Models) Full Scale Step (2mA), 10 to 100Ω Load		350			*	1000		*	*		*	*	ns
1kΩ Load		1			*	3		*	*		*	*	μs
OUTPUT													
VOLTAGE OUTPUT MODELS													
DAC701 (CSB Code)					0 to +10			*					V
DAC703 (COB Code)		±5	±10		*			*		*	*		V
Output Current				*			*			*	*		mA
Output Impedance			0.15		*			*		*	*		Ω
Short Circuit to Common Duration			Indefinite		*			*		*	*		
CURRENT OUTPUT MODELS													
DAC702 (COB Code)(10)		±1			*			*		*	*		mA
Output Impedance(10)		2.45			*			*		*	*		kΩ
Compliance Voltage		±2.5			*			*		*	*		V

SPECIFICATIONS (CONT)

At +25°C and rated power supplies, unless otherwise noted.

PARAMETER	DAC702/703J			DAC701/702/703K			DAC701/702/703B, S			DAC701/702/703L, C			UNITS
	MIN	TYP	MAX	MIN	TYP	MAX	MIN	TYP	MAX	MIN	TYP	MAX	
REFERENCE VOLTAGE													
Voltage		+6.3		+6.0	+6.3	+6.6	+6.24	+6.3	+6.36	*	*	*	V
Source Current Available for External Loads		+2.5		+1.5	*		*	*		*	*	*	mA
Temperature Coefficient		±10			*	±25		*	±15		*	*	ppm/°C
Short Circuit to Common Duration		Indefinite			*			*			*		
POWER SUPPLY REQUIREMENTS													
Voltage: +V _{CC}	13.5	15	16.5	*	*	*	*	*	*	*	*	*	V
-V _{CC}	13.5	15	16.5	*	*	*	*	*	*	*	*	*	V
V _{DD}	+4.5	+5	+16.5	*	*	*	*	*	*	*	*	*	V
Current (No Load):													
DAC702													
(I _{OUT} Models)													
+V _{CC}		+10	+25		*	*		*	*		*	*	mA
-V _{CC}		-13	-25		*	*		*	*		*	*	mA
V _{DD}		+4	+8		*	*		*	*		*	*	mA
DAC701/703													
(V _{OUT} Models)													
+V _{CC}		+16	+30		*	*		*	*		*	*	mA
-V _{CC}		-18	-30		*	*		*	*		*	*	mA
V _{DD}		+4	+8		*	*		*	*		*	*	mA
Power Dissipation:													
(V _{DD} = +5.0V) ⁽¹¹⁾													
DAC702		365			*	790		*	630		*	*	mW
DAC701/703		530			*	940		*	780		*	*	mW
Power Supply Rejection:													
+V _{CC}		±0.0015	±0.006		*	*		*	±0.003		*	*	% of FSR/%V _{CC}
-V _{CC}		±0.0015	±0.006		*	*		*	±0.003		*	*	% of FSR/%V _{CC}
V _{DD}		±0.0001	±0.001		*	*		*	*		*	*	% of FSR/%V _{DD}
TEMPERATURE RANGE													
Specification:													
B, C Grades							-25		+85	*		*	°C
S Grades							-55		+125				°C
J, K, L Grades	0		+70	*		*				0		+70	°C
Storage: Ceramic				-60		+150	*		*	*		*	°C
Plastic, SOIC	-60		+100	*		*							°C

* Specification same as model to the left.

NOTES: (1) Digital inputs are TTL, LSTTL, 54/74C, 54/74HC, and 54/74HTC compatible over the operating voltage range of V_{DD} = +5V to +15V and over the specified temperature range. The input switching threshold remains at the TTL threshold of 1.4V over the supply range of V_{DD} = +5V to +15V. As logic "0" and logic "1" inputs vary over 0V to +0.8V and +2.4V to +10V respectively, the change in the D/A converter output voltage will not exceed ±0.0015% of FSR for the LH and CH grades, ±0.003% of FSR for the BH grade and ±0.006% of FSR for the KG grade. (2) DAC702 (current-output models) is specified and tested with an external output operational amplifier connected using the internal feedback resistor in all parameters except settling time. (3) FSR means full-scale range and is 20V for the ±10V range (DAC703), 10V for the 0 to +10V range (DAC701). FSR is 2mA for the ±1mA range (DAC702). (4) ±0.0015% of full-scale range is equivalent to 1LSB in 15-bit resolution. ±0.003% of full-scale range is equivalent to 1LSB in 14-bit resolution. ±0.006% of full-scale range is equivalent to 1LSB in 13-bit resolution. (5) Adjustable to zero with external trim potentiometer. Adjusting the gain potentiometer rotates the transfer function around the zero point. (6) Error at input code FFFF_H for DAC701, 7FFF_H for DAC702 and DAC703. (7) With gain and zero errors adjusted to zero at +25°C. (8) Maximum represents the 3σ limit. Not 100% tested for this parameter. (9) At the major carry, 7FFF_H to 8000_H and 8000_H to 7FFF_H. (10) Tolerance on output impedance and output current is ±30%. (11) Power dissipation is an additional 40mW when V_{DD} is operated at +15V.

The information provided herein is believed to be reliable; however, BURR-BROWN assumes no responsibility for inaccuracies or omissions. BURR-BROWN assumes no responsibility for the use of this information, and all use of such information shall be entirely at the user's own risk. Prices and specifications are subject to change without notice. No patent rights or licenses to any of the circuits described herein are implied or granted to any third party. BURR-BROWN does not authorize or warrant any BURR-BROWN product for use in life support devices and/or systems.

CONNECTION DIAGRAMS

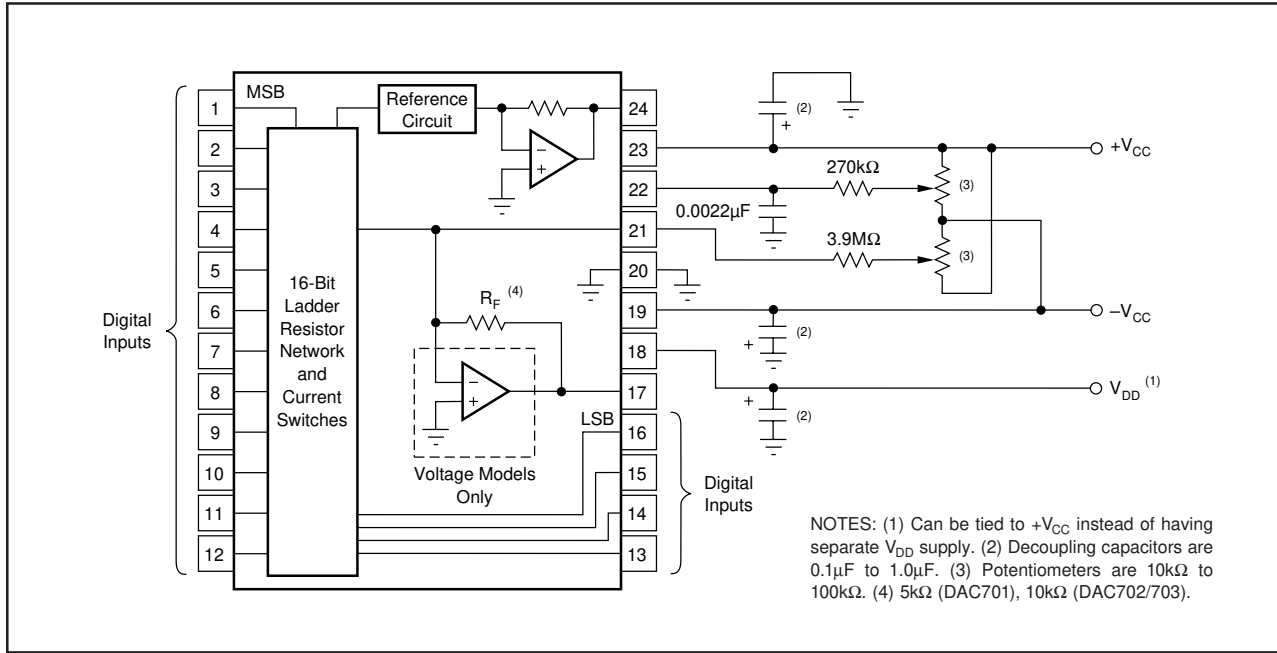

PIN ASSIGNMENTS

PIN #	ALL PACKAGES	
	DAC702	DAC701/703
1	Bit 1 (MSB)	Bit 1 (MSB)
2	Bit 2	Bit 2
3	Bit 3	Bit 3
4	Bit 4	Bit 4
5	Bit 5	Bit 5
6	Bit 6	Bit 6
7	Bit 7	Bit 7
8	Bit 8	Bit 8
9	Bit 9	Bit 9
10	Bit 10	Bit 10
11	Bit 11	Bit 11
12	Bit 12	Bit 12
13	Bit 13	Bit 13
14	Bit 14	Bit 14
15	Bit 15	Bit 15
16	Bit 16 (LSB)	Bit 16 (LSB)
17	R _{FEEDBACK}	V _{OUT}
18	V _{DD}	V _{DD}
19	-V _{CC}	-V _{CC}
20	Common	Common
21	I _{OUT}	Summing Junction (Zero Adjust)
22	Gain Adjust	Gain Adjust
23	+V _{CC}	+V _{CC}
24	+6.3V Reference Output	+6.3V Reference Output

ABSOLUTE MAXIMUM RATINGS⁽¹⁾

+V _{CC} to Common	0V, +18V
-V _{CC} to Common	0V, -18V
V _{DD} to Common	0V, +18V
Digital Data Inputs to Common	-1V, +18V
Reference Out to Common	Indefinite Short to Common
External Voltage Applied to R _F (DAC702)	±18V
External Voltage Applied to D/A Output (DAC701/703)	-5V to +5V
V _{OUT} (DAC701/703)	Indefinite Short to Common
Power Dissipation	1W
Storage Temperature	-60°C to +150°C
Lead Temperature (soldering, 10s)	300°C

NOTE: (1) Stresses above those listed under "Absolute Maximum Ratings" may cause permanent damage to the device. Exposure to absolute maximum conditions for extended periods may affect device reliability.



ELECTROSTATIC DISCHARGE SENSITIVITY

This integrated circuit can be damaged by ESD. Burr-Brown recommends that all integrated circuits be handled with appropriate precautions. Failure to observe proper handling and installation procedures can cause damage.

ESD damage can range from subtle performance degradation to complete device failure. Precision integrated circuits may be more susceptible to damage because very small parametric changes could cause the device not to meet its published specifications.

PACKAGE/ORDERING INFORMATION

PRODUCT	PACKAGE	PACKAGE DRAWING NUMBER ⁽¹⁾	OUTPUT CONFIGURATION	TEMPERATURE RANGE	LINEARITY ERROR, MAX AT+25°C (% of FSR)	GAIN DRIFT, MAX (ppm/°C)
DAC703JP	24-Pin Plastic DIP	167	±1mA, ±10V	0°C to +70°C	±0.006	±30
DAC703KP	24-Pin Plastic DIP	167	±1mA, ±10V	0°C to +70°C	±0.003	±25
DAC701KH	24-Pin Ceramic DIP	165	0 to -2mA, 0 to +10V	0°C to +70°C	±0.003	±25
DAC702KH	24-Pin Ceramic DIP	165	±1mA, ±10V	0°C to +70°C	±0.003	±25
DAC703KH	24-Pin Ceramic DIP	165	±1mA, ±10V	0°C to +70°C	±0.003	±25
DAC701BH	24-Pin Ceramic DIP	165	0 to -2mA, 0 to +10V	-25°C to +85°C	±0.003	±15
DAC702BH	24-Pin Ceramic DIP	165	±1mA, ±10V	-25°C to +85°C	±0.003	±15
DAC703BH	24-Pin Ceramic DIP	165	±1mA, ±10V	-25°C to +85°C	±0.003	±15
DAC701LH	24-Pin Ceramic DIP	165	0 to -2mA, 0 to +10V	0°C to +70°C	±0.0015	±10
DAC702LH	24-Pin Ceramic DIP	165	±1mA, ±10V	0°C to +70°C	±0.0015	±10
DAC703LH	24-Pin Ceramic DIP	165	±1mA, ±10V	0°C to +70°C	±0.0015	±10
DAC701CH	24-Pin Ceramic DIP	165	0 to -2mA, 0 to +10V	-25°C to +85°C	±0.0015	±10
DAC702CH	24-Pin Ceramic DIP	165	±1mA, ±10V	-25°C to +85°C	±0.0015	±10
DAC703CH	24-Pin Ceramic DIP	165	±1mA, ±10V	-25°C to +85°C	±0.0015	±10
DAC701SH	24-Pin Ceramic DIP	165	0 to -2mA, 0 to +10V	-55°C to +125°C	±0.003	±15
DAC702SH	24-Pin Ceramic DIP	165	±1mA, ±10V	-55°C to +125°C	±0.003	±15
DAC703SH	24-Pin Ceramic DIP	165	±1mA, ±10V	-55°C to +125°C	±0.003	±15
DAC703JU	24-Pin SOIC	239	±10V	0°C to +70°C	±0.006	±30
DAC703KU	24-Pin SOIC	239	±10V	0°C to +70°C	±0.003	±25

NOTE: (1) For detailed drawing and dimension table, please see end of data sheet, or Appendix C of Burr-Brown IC Data Book.

DISCUSSION OF SPECIFICATIONS

DIGITAL INPUT CODES

The DAC701/702/703 accept complementary digital input codes in either binary format (CSB, unipolar or COB, bipolar). The COB models DAC702/703 may be connected by the user for either complementary offset binary (COB) or complementary two's complement (CTC) codes (see Table I).

DIGITAL INPUT CODES	ANALOG OUTPUT		
	DAC701 Complementary Straight Binary (CSB)	DAC702/703 Complementary Offset Binary (COB)	DAC702/703 Complementary Two's Complement (CTC)*
0000 _H	+ Full Scale	+ Full Scale	-1LSB
7FFF _H	+1/2 Full Scale	Bipolar Zero	- Full Scale
8000 _H	+1/2 Full Scale	-1LSB	+ Full Scale
FFFF _H	-1LSB Zero	- Full Scale	Bipolar Zero

* Invert the MSB of the COB code with an external inverter to obtain CTC code.

TABLE I. Digital Input Codes.

ACCURACY

Linearity

This specification describes one of the most important measures of performance of a D/A converter. Linearity error is the deviation of the analog output from a straight line drawn through the end points (all bits ON point and all bits OFF point).

Differential Linearity Error

Differential linearity error (DLE) of a D/A converter is the deviation from an ideal 1LSB change in the output from one adjacent output state to the next. A differential linearity error specification of $\pm 1/2$ LSB means that the output step sizes can be between $1/2$ LSB and $3/2$ LSB when the input changes from one adjacent input state to the next. A negative DLE specification of no more than -1LSB (-0.006% for 14-bit resolution) insures monotonicity.

Monotonicity

Monotonicity assures that the analog output will increase or remain the same for increasing input digital codes. The DAC701/702/703 are specified to be monotonic to 14 bits over the entire specification temperature range.

DRIFT

Gain Drift

Gain drift is a measure of the change in the full-scale range output over temperature expressed in parts per million per degree centigrade (ppm/°C). Gain drift is established by: (1) testing the end point differences for each D/A at t_{MIN} , +25°C and t_{MAX} ; (2) calculating the gain error with respect to the +25°C value; and (3) dividing by the temperature change.

Zero Drift

Zero drift is a measure of the change in the output with FFFF_H (DAC701) applied to the digital inputs over the specified temperature range. For the bipolar models, zero is measured at 7FFF_H (bipolar zero) applied to the digital inputs. This code corresponds to zero volts (DAC703) or zero milliamps (DAC702) at the analog output. The maximum change in offset at t_{MIN} or t_{MAX} is referenced to the zero error at +25°C and is divided by the temperature change. This drift is expressed in parts per million of full scale range per degree centigrade (ppm of FSR/°C).

SETTLING TIME

Settling time of the D/A is the total time required for the analog output to settle within an error band around its final value after a change in digital input. Refer to Figure 1 for typical values for this family of products.

Voltage Output

Settling times are specified to $\pm 0.003\%$ of FSR ($\pm 1/2$ LSB for 14 bits) for two input conditions: a full-scale range change of 20V (DAC703) or 10V (DAC701) and a 1LSB change at the "major carry," the point at which the worst-case settling time occurs. (This is the worst-case point since all of the input bits change when going from one code to the next).

Current Output

Settling times are specified to $\pm 0.003\%$ of FSR for a full-scale range change for two output load conditions: one for 10 Ω to 100 Ω and one for 1000 Ω . It is specified this way because the output RC time constant becomes the dominant factor in determining settling time for large resistive loads.

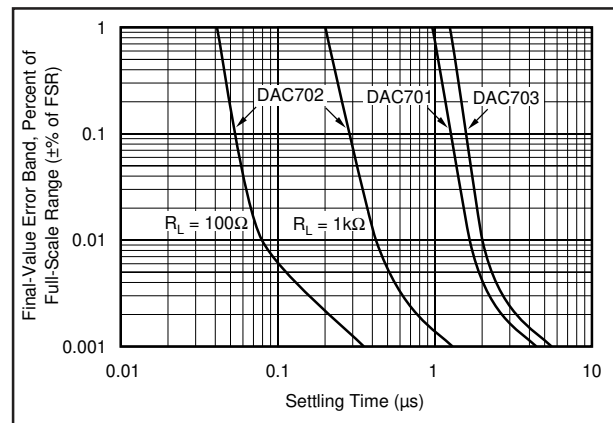

FIGURE 1. Final-Value Error Band vs Full-Scale Range Settling Time.

COMPLIANCE VOLTAGE

Compliance voltage applies only to current output models. It is the maximum voltage swing allowed on the output current pin while still being able to maintain specified accuracy.

POWER SUPPLY SENSITIVITY

Power supply sensitivity is a measure of the effect of a change in a power supply voltage on the D/A converter output. It is defined as a percent of FSR change in the output per percent of change in either the positive supply (+V_{CC}), negative supply (-V_{CC}) or logic supply (V_{DD}) about the nominal power supply voltages (see Figure 2).

It is specified for DC or low frequency changes. The typical performance curve in Figure 2 shows the effect of high frequency changes in power supply voltages.

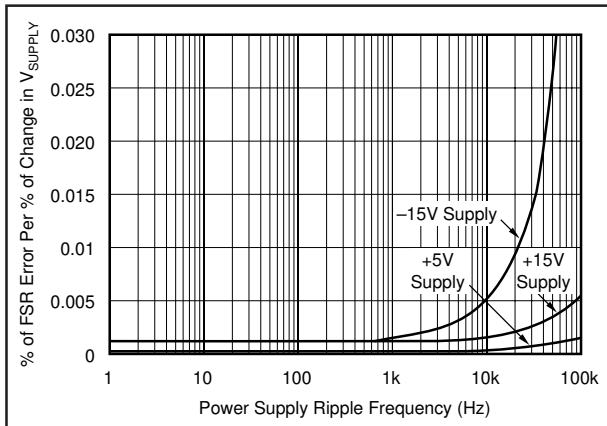

FIGURE 2. Power Supply Rejection vs Power Supply Ripple Frequency.

REFERENCE SUPPLY

All models have an internal low-noise +6.3V reference voltage derived from an on-chip buried zener diode. This reference voltage, available to the user, has a tolerance of $\pm 5\%$ (KH models) and $\pm 1\%$ (BH models). A minimum of 1.5mA is available for external loads. Since the output impedance of the reference output is typically 1W, the external load should remain constant.

If a varying load is to be driven by the reference supply, an external buffer amplifier is recommended to drive the load in order to isolate the bipolar offset (connected internally to the reference) from load variations.

OPERATING INSTRUCTIONS

POWER SUPPLY CONNECTIONS

For optimum performance and noise rejection, power supply decoupling capacitors should be added as shown in the Connection Diagram. $1\mu\text{F}$ tantalum capacitors should be located close to the D/A converter.

EXTERNAL ZERO AND GAIN ADJUSTMENT

Zero and gain may be trimmed by installing external zero and gain potentiometers. Connect these potentiometers as shown in the Connection Diagram and adjust as described below. TCR of the potentiometers should be 100ppm/ $^{\circ}\text{C}$ or

less. The $3.9\text{M}\Omega$ and $270\text{k}\Omega$ resistors ($\pm 20\%$ carbon or better) should be located close to the D/A converter to prevent noise pickup. If it is not convenient to use these high-value resistors, an equivalent “T” network, as shown in Figure 3, may be substituted in place of the $3.9\text{M}\Omega$ part. A $0.001\mu\text{F}$ to $0.01\mu\text{F}$ ceramic capacitor should be connected from Gain Adjust to Common to prevent noise pickup. Refer to Figures 4 and 5 for the relationship of zero and gain adjustments to unipolar and bipolar D/A converters.

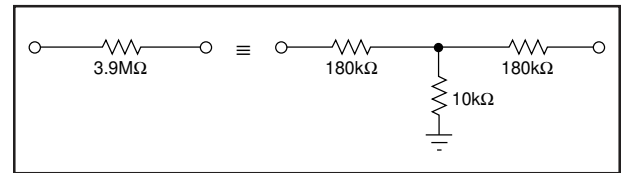

FIGURE 3. Equivalent Resistances.

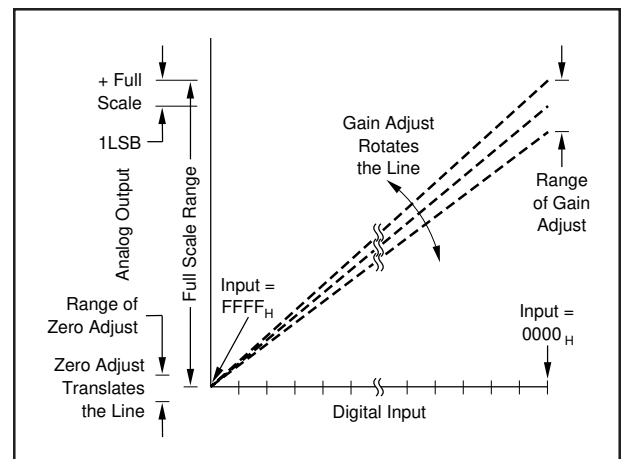

FIGURE 4. Relationship of Zero and Gain Adjustments for Unipolar D/A Converters, DAC701.

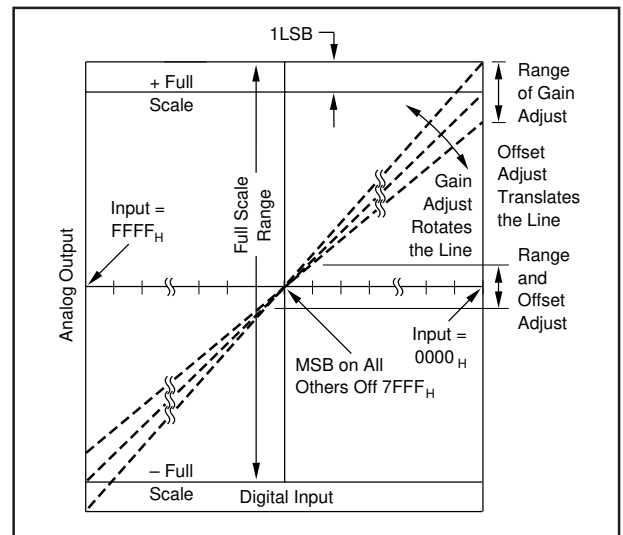

FIGURE 5. Relationship of Zero and Gain Adjustments for Bipolar D/A Converters, DAC702 and DAC703.

Zero Adjustment

For unipolar (CSB) configurations, apply the digital input code that produces zero voltage or zero current output and adjust the zero potentiometer for zero output.

For bipolar (COB, CTC) configurations, apply the digital input code that produces zero output voltage or current. See Table II for corresponding codes and the Connection Diagram for zero adjustment circuit connections. Zero calibration should be made before gain calibration.

Gain Adjustment

Apply the digital input that gives the maximum positive output voltage. Adjust the gain potentiometer for this positive full scale voltage. See Table II for positive full scale voltages and the Connection Diagram for gain adjustment circuit connections.

INSTALLATION CONSIDERATIONS

This D/A converter family is laser-trimmed to 14-bit linearity. The design of the device makes the 16-bit resolution available. If 16-bit resolution is not required, bit 15 and bit 16 should be connected to V_{DD} through a single 1k Ω resistor.

Due to the extremely high resolution and linearity of the D/A converter, system design problems such as grounding and contact resistance become very important. For a 16-bit converter with a 10V full-scale range, 1LSB is 153 μ V. With a load current of 5mA, series wiring and connector resistance of only 30m Ω will cause the output to be in error by 1LSB. To understand what this means in terms of a system layout, the resistance of #23 wire is about 0.021 Ω /ft. Neglecting contact resistance, less than 18 inches of wire will produce a 1LSB error in the analog output voltage!

In Figures 6, 7, and 8, lead and contact resistances are represented by R_1 through R_5 . As long as the load resistance R_L is constant, R_2 simply introduces a gain error and can be removed during initial calibration. R_3 is part of R_L , if the output voltage is sensed at Common, and therefore introduces no error. If R_L is variable, then R_2 should be less than $R_{L\text{MIN}}/2^{16}$ to reduce voltage drops due to wiring to less than 1LSB. For example, if $R_{L\text{MIN}}$ is 5k Ω , then R_2 should be less than 0.08 Ω . R_L should be located as close as possible to the D/A converter for optimum performance. The effect of R_4 is negligible.

In many applications it is impractical to sense the output voltage at the output pin. Sensing the output voltage at the system ground point is permissible with the DAC700 family because the D/A converter is designed to have a constant return current of approximately 2mA flowing from Common. The variation in this current is under 20 μ A (with changing input codes), therefore R_4 can be as large as 3 Ω without adversely affecting the linearity of the D/A converter. The voltage drop across R_4 ($R_4 \times 2\text{mA}$) appears as a zero error and can be removed with the zero calibration adjustment. This alternate sensing point (the system ground point) is shown in Figures 6, 7, and 8.

Figures 7 and 8 show two methods of connecting the current output models (DAC702) with external precision output op amps. By sensing the output voltage at the load resistor (ie, by connecting R_F to the output of A_1 at R_L), the effect of R_1 and R_2 is greatly reduced. R_1 will cause a gain error but is independent of the value of R_L and can be eliminated by initial calibration adjustments. The effect of R_2 is negligible because it is inside the feedback loop of the output op amp and is therefore greatly reduced by the loop gain.

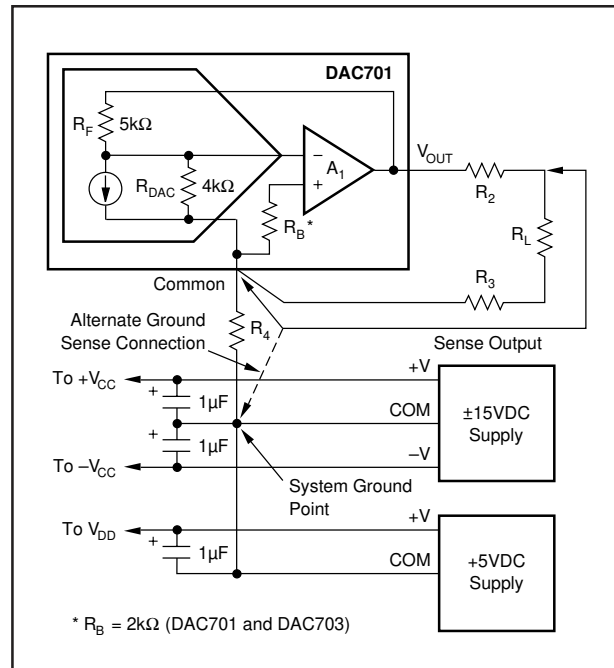

FIGURE 6. Output Circuit for Voltage Models.

VOLTAGE OUTPUT MODELS							
DIGITAL INPUT CODE		ANALOG OUTPUT					
		DAC701 UNIPOLAR			DAC703 BIPOLAR		
		16-BIT	15-BIT	14-BIT	16-BIT	15-BIT	14-BIT
1LSB	(μ V)	153	305	610	305	610	1224
0000 _H	(V)	+9.99985	+9.99969	+9.99939	+9.99960	+9.99939	+9.99878
FFFF _H	(V)	0	0	0	-10.0000	-10.0000	-10.0000

ANALOG OUTPUT MODEL				
DIGITAL INPUT CODE		ANALOG OUTPUT		
		DAC702 BIPOLAR		
		16-BIT	15-BIT	14-BIT
1LSB	(μ A)	0.031	0.061	0.122
0000 _H	(mA)	-0.99997	-0.99994	-0.99988
FFFF _H	(mA)	+1.00000	+1.00000	+1.00000

TABLE II. Digital Input and Analog Output Relationships.

If the output cannot be sensed at Common or the system ground point as mentioned above, the differential output circuit shown in Figure 8 is recommended. In this circuit the output voltage is sensed at the load common and not at the D/A converter common as in the previous circuits. The value of R_6 and R_7 must be adjusted for maximum common-mode rejection at R_L . Note that if R_3 is negligible, the circuit of Figure 8 can be reduced to the one shown in Figure 7. Again the effect of R_4 is negligible.

The D/A converter and the wiring to its connectors should be located to provide optimum isolation from sources of RFI and EMI. The key concept in elimination of RF radiation or pickup is loop area; therefore, signal leads and their return conductors should be kept close together. This reduces the external magnetic field along with any radiation. Also, if a single lead and its return conductor are wired close together, they present a small flux-capture cross section for any external field. This reduces radiation pickup in the circuit.

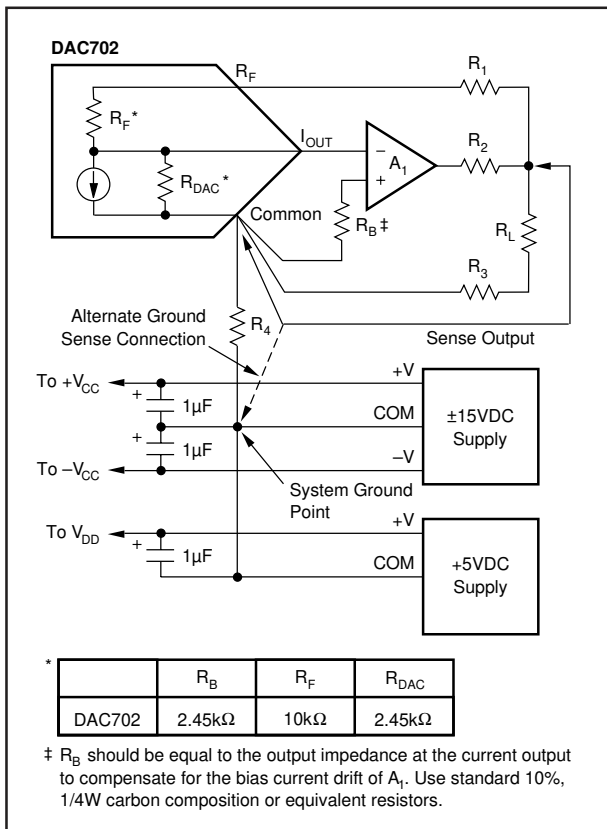

FIGURE 7. Preferred External Op Amp Configuration.

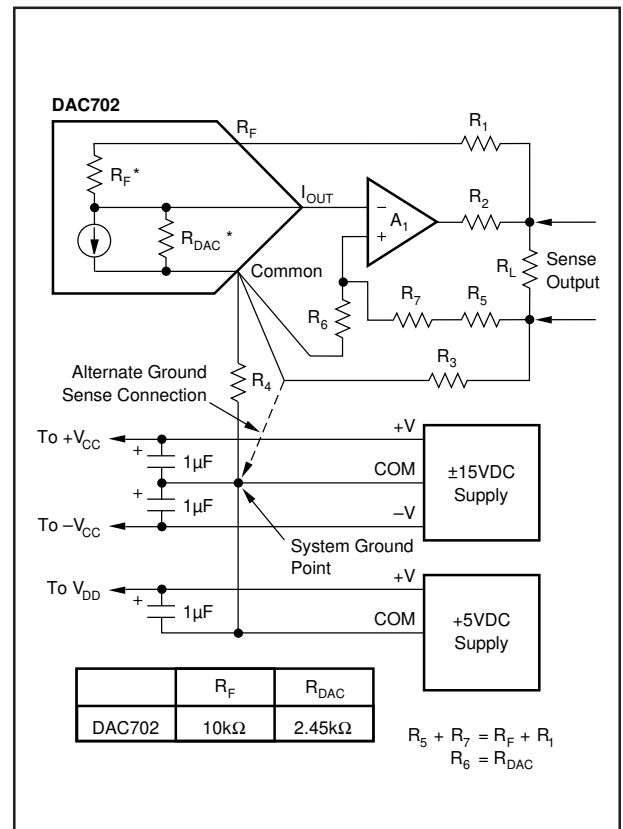

FIGURE 8. Differential Sensing Output Op Amp Configuration.

APPLICATIONS

DRIVING AN EXTERNAL OP AMP WITH CURRENT OUTPUT D/AS

DAC702 is current output devices and will drive the summing junction of an op amp to produce an output voltage as shown in Figure 9. Use of the internal feedback resistor is required to obtain specified gain accuracy and low gain drift.

DAC702 can be scaled for any desired voltage range with an external feedback resistor, but at the expense of increased drifts of up to $\pm 50\text{ppm}/^\circ\text{C}$. The resistors in the DAC702 ratio track to $\pm 1\text{ppm}/^\circ\text{C}$ but their absolute TCR may be as high as $\pm 50\text{ppm}/^\circ\text{C}$.

An alternative method of scaling the output voltage of the D/A converter and preserving the low gain drift is shown in Figure 10.

OUTPUTS LARGER THAN 20V RANGE

For output voltage ranges larger than $\pm 10\text{V}$, a high voltage op amp may be employed with an external feedback resistor. Use I_{OUT} values of $\pm 1\text{mA}$ for bipolar voltage ranges and -2mA for unipolar voltage ranges (see Figure 11). Use protection diodes as shown when a high voltage op amp is used.

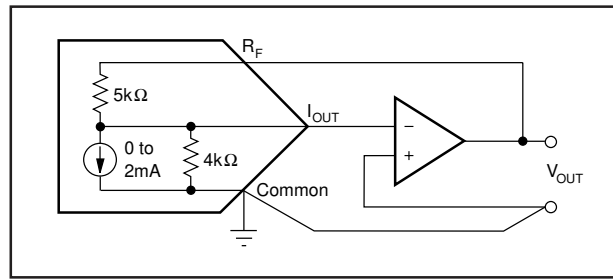

FIGURE 9. External Op Amp Using Internal Feedback Resistors.

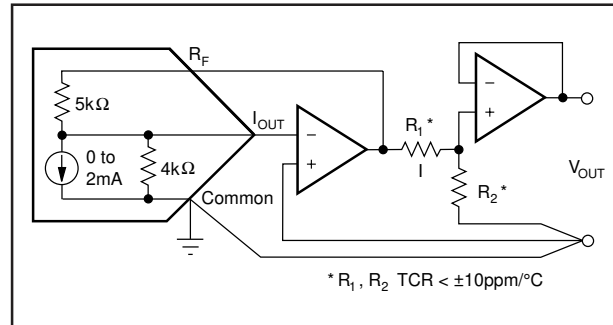

FIGURE 10. External Op Amp Using Internal and External Feedback Resistors to Maintain Low Gain Drift.

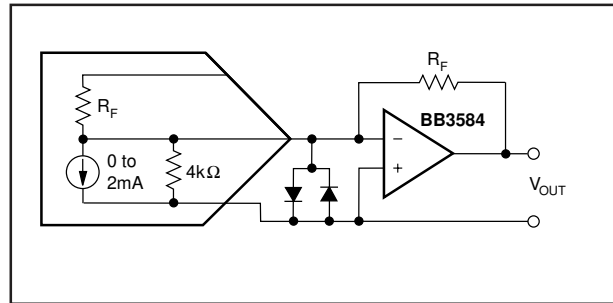

FIGURE 11. External Op Amp Using External Feedback Resistors.

PACKAGING INFORMATION

Orderable Device	Status ⁽¹⁾	Package Type	Package Drawing	Pins	Package Qty	Eco Plan ⁽²⁾	Lead/Ball Finish	MSL Peak Temp ⁽³⁾
DAC701KH	OBSOLETE	CDIP SB	JDM	24		TBD	Call TI	Call TI
DAC703BH	OBSOLETE	CDIP SB	JDM	24		TBD	Call TI	Call TI
DAC703BH-BI	OBSOLETE	CDIP SB	JD	24		TBD	Call TI	Call TI
DAC703CH	OBSOLETE	CDIP SB	JDM	24		TBD	Call TI	Call TI
DAC703CH-BI	OBSOLETE	CDIP SB	JD	24		TBD	Call TI	Call TI
DAC703JP	OBSOLETE	PDIP	NTA	24		TBD	Call TI	Call TI
DAC703KH	OBSOLETE	CDIP SB	JDM	24		TBD	Call TI	Call TI
DAC703KH-4	OBSOLETE	CDIP SB	JDM	24		TBD	Call TI	Call TI
DAC703KH-BI	OBSOLETE	CDIP SB	JDM	24		TBD	Call TI	Call TI
DAC703KP	OBSOLETE	PDIP	NTA	24		TBD	Call TI	Call TI
DAC703LH	OBSOLETE	CDIP SB	JDM	24		TBD	Call TI	Call TI
DAC703SH	OBSOLETE	CDIP SB	JDM	24		TBD	Call TI	Call TI

⁽¹⁾ The marketing status values are defined as follows:

ACTIVE: Product device recommended for new designs.

LIFEBUY: TI has announced that the device will be discontinued, and a lifetime-buy period is in effect.

NRND: Not recommended for new designs. Device is in production to support existing customers, but TI does not recommend using this part in a new design.

PREVIEW: Device has been announced but is not in production. Samples may or may not be available.

OBSOLETE: TI has discontinued the production of the device.

⁽²⁾ Eco Plan - The planned eco-friendly classification: Pb-Free (RoHS) or Green (RoHS & no Sb/Br) - please check <http://www.ti.com/productcontent> for the latest availability information and additional product content details.

TBD: The Pb-Free/Green conversion plan has not been defined.

Pb-Free (RoHS): TI's terms "Lead-Free" or "Pb-Free" mean semiconductor products that are compatible with the current RoHS requirements for all 6 substances, including the requirement that lead not exceed 0.1% by weight in homogeneous materials. Where designed to be soldered at high temperatures, TI Pb-Free products are suitable for use in specified lead-free processes.

Green (RoHS & no Sb/Br): TI defines "Green" to mean Pb-Free (RoHS compatible), and free of Bromine (Br) and Antimony (Sb) based flame retardants (Br or Sb do not exceed 0.1% by weight in homogeneous material)

⁽³⁾ MSL, Peak Temp. -- The Moisture Sensitivity Level rating according to the JEDEC industry standard classifications, and peak solder temperature.

Important Information and Disclaimer:The information provided on this page represents TI's knowledge and belief as of the date that it is provided. TI bases its knowledge and belief on information provided by third parties, and makes no representation or warranty as to the accuracy of such information. Efforts are underway to better integrate information from third parties. TI has taken and continues to take reasonable steps to provide representative and accurate information but may not have conducted destructive testing or chemical analysis on incoming materials and chemicals. TI and TI suppliers consider certain information to be proprietary, and thus CAS numbers and other limited information may not be available for release.

In no event shall TI's liability arising out of such information exceed the total purchase price of the TI part(s) at issue in this document sold by TI to Customer on an annual basis.

IMPORTANT NOTICE

Texas Instruments Incorporated and its subsidiaries (TI) reserve the right to make corrections, modifications, enhancements, improvements, and other changes to its products and services at any time and to discontinue any product or service without notice. Customers should obtain the latest relevant information before placing orders and should verify that such information is current and complete. All products are sold subject to TI's terms and conditions of sale supplied at the time of order acknowledgment.

TI warrants performance of its hardware products to the specifications applicable at the time of sale in accordance with TI's standard warranty. Testing and other quality control techniques are used to the extent TI deems necessary to support this warranty. Except where mandated by government requirements, testing of all parameters of each product is not necessarily performed.

TI assumes no liability for applications assistance or customer product design. Customers are responsible for their products and applications using TI components. To minimize the risks associated with customer products and applications, customers should provide adequate design and operating safeguards.

TI does not warrant or represent that any license, either express or implied, is granted under any TI patent right, copyright, mask work right, or other TI intellectual property right relating to any combination, machine, or process in which TI products or services are used. Information published by TI regarding third-party products or services does not constitute a license from TI to use such products or services or a warranty or endorsement thereof. Use of such information may require a license from a third party under the patents or other intellectual property of the third party, or a license from TI under the patents or other intellectual property of TI.

Reproduction of information in TI data books or data sheets is permissible only if reproduction is without alteration and is accompanied by all associated warranties, conditions, limitations, and notices. Reproduction of this information with alteration is an unfair and deceptive business practice. TI is not responsible or liable for such altered documentation.

Resale of TI products or services with statements different from or beyond the parameters stated by TI for that product or service voids all express and any implied warranties for the associated TI product or service and is an unfair and deceptive business practice. TI is not responsible or liable for any such statements.

Following are URLs where you can obtain information on other Texas Instruments products and application solutions:

Products		Applications	
Amplifiers	amplifier.ti.com	Audio	www.ti.com/audio
Data Converters	dataconverter.ti.com	Automotive	www.ti.com/automotive
DSP	dsp.ti.com	Broadband	www.ti.com/broadband
Interface	interface.ti.com	Digital Control	www.ti.com/digitalcontrol
Logic	logic.ti.com	Military	www.ti.com/military
Power Mgmt	power.ti.com	Optical Networking	www.ti.com/opticalnetwork
Microcontrollers	microcontroller.ti.com	Security	www.ti.com/security
		Telephony	www.ti.com/telephony
		Video & Imaging	www.ti.com/video
		Wireless	www.ti.com/wireless

Mailing Address: Texas Instruments
Post Office Box 655303 Dallas, Texas 75265

Copyright © 2005, Texas Instruments Incorporated