

REVISIONS					
REV	DESCRIPTION	DATE	BY	APP'D	
L3	REVISED PER ECR-21-118133	22OCT2021	SS	VS	

- 1 PARTS COMPLY WITH AMP SOLDERABILITY SPECIFICATION 109-11-5.
- 2 CIRCUIT IDENTIFICATION CHARACTERS ARE ADJACENT TO THE INDICATED CAVITIES, BUT LOCATION AND ORIENTATION MAY DIFFER FROM PRINT.
- 3 CONTACT IS PLATED OVERALL WITH 0.00127 [.000050] MIN NICKEL, THEN 0.00076 [.000030] GOLD OVER CONTACT LENGTH INDICATED AND MATTE TIN FINISH ON SOLDER TAIL END.
- 4 DIMENSIONS IN BRACKETS ARE IN INCHES.
- 5 OPTIONAL CONSTRUCTION MAY DELETE THIS RIB.
- 6 TOLERANCE NON-CUMULATIVE
- 7 CONTACT IS PLATED OVERALL WITH 0.00127 [.000050] MIN NICKEL, THEN 0.00076 [.000030] GOLD OVER CONTACT LENGTH INDICATED AND MATTE TIN FINISH ON SOLDER TAIL END.
- 8 SUPERSEDED BY 3-350945-0
- 9 DIMENSIONS SHOWN REPRESENT PRODUCT IN DRY CONDITION. ADDITIONAL 2% GROWTH DUE TO END USE LOCATION MOISTURE ABSORPTION MAY OCCUR AND SHOULD BE ACCOUNTED FOR

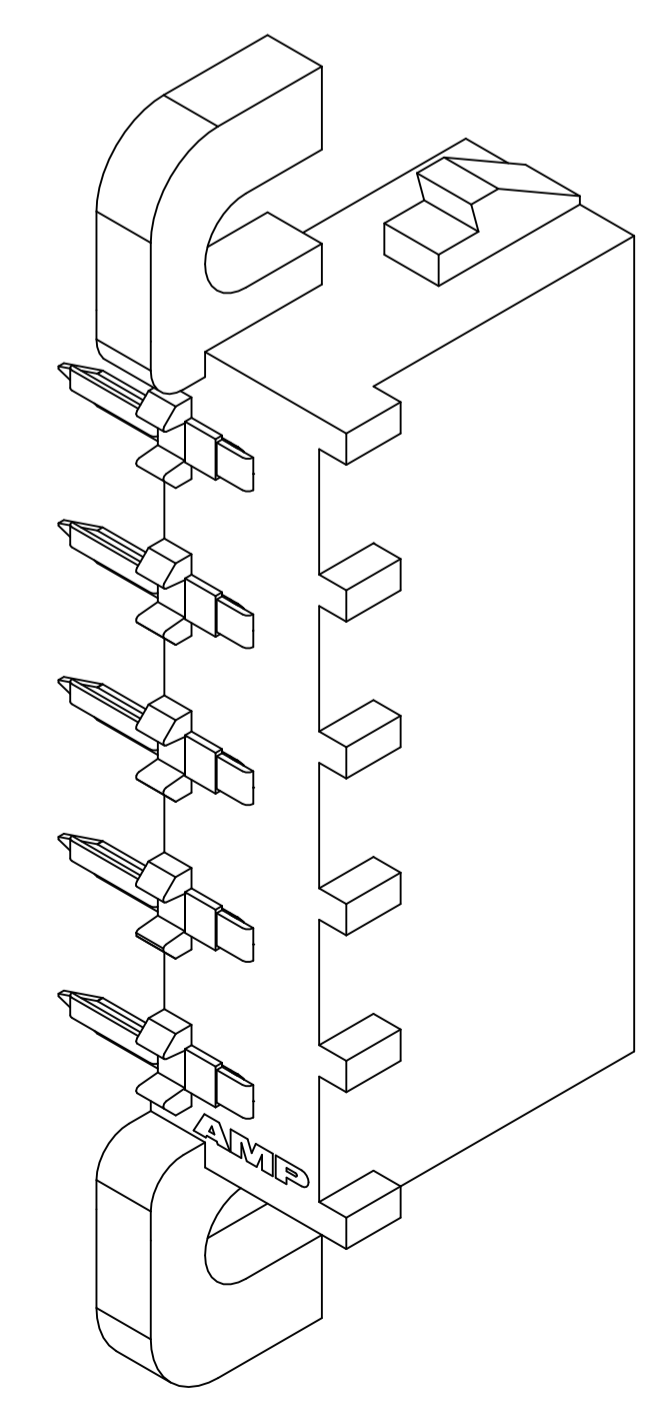

3-DIMENSIONAL MODEL NTS

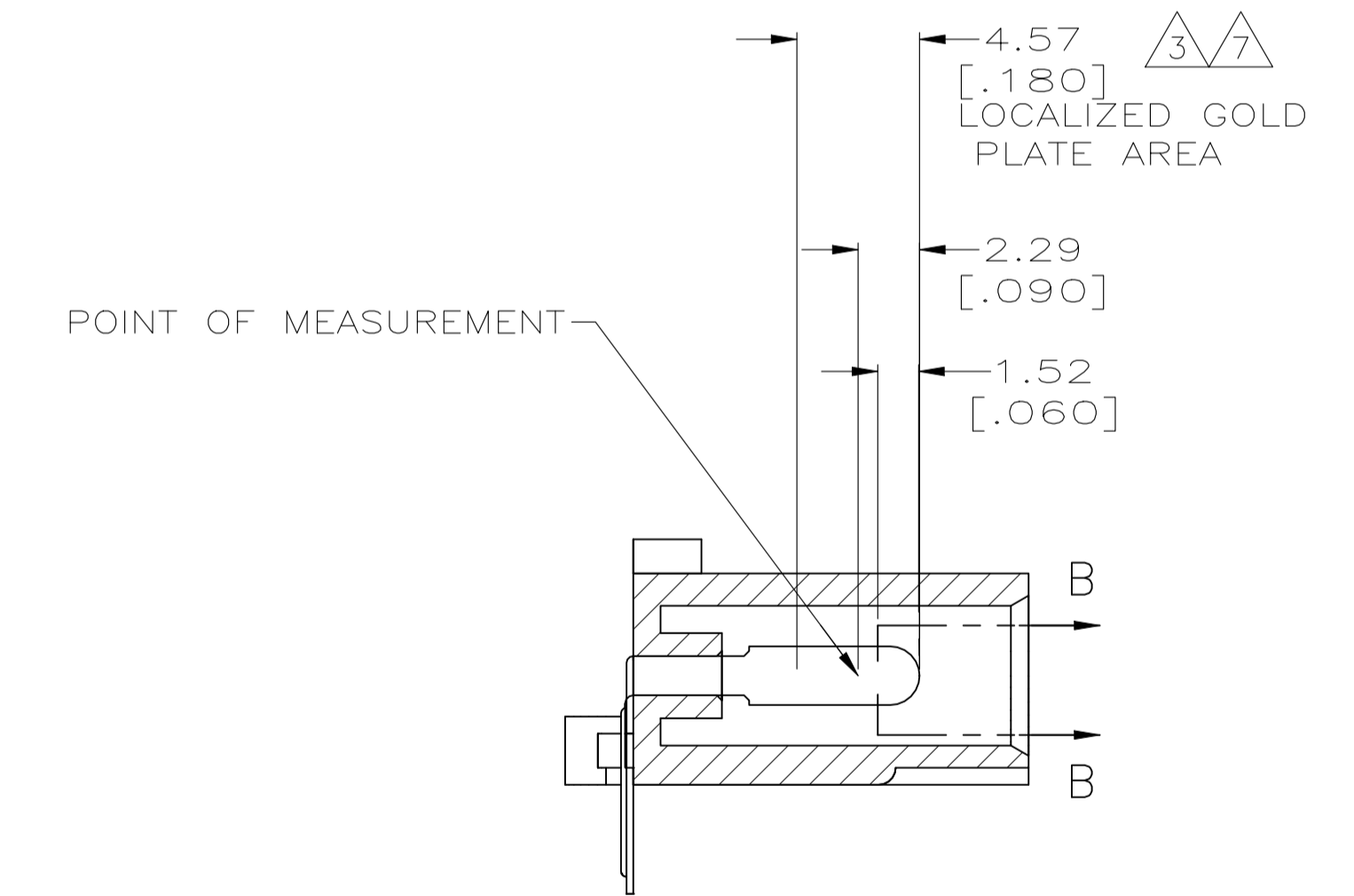
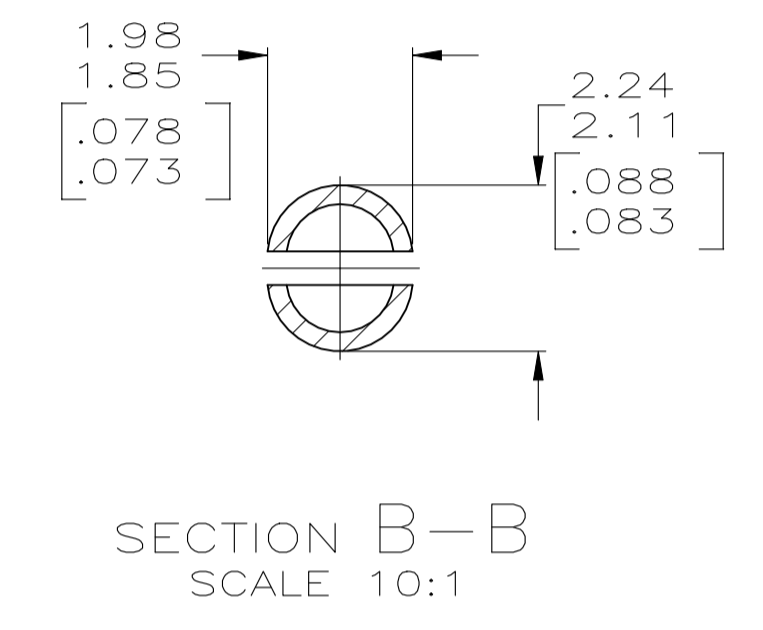
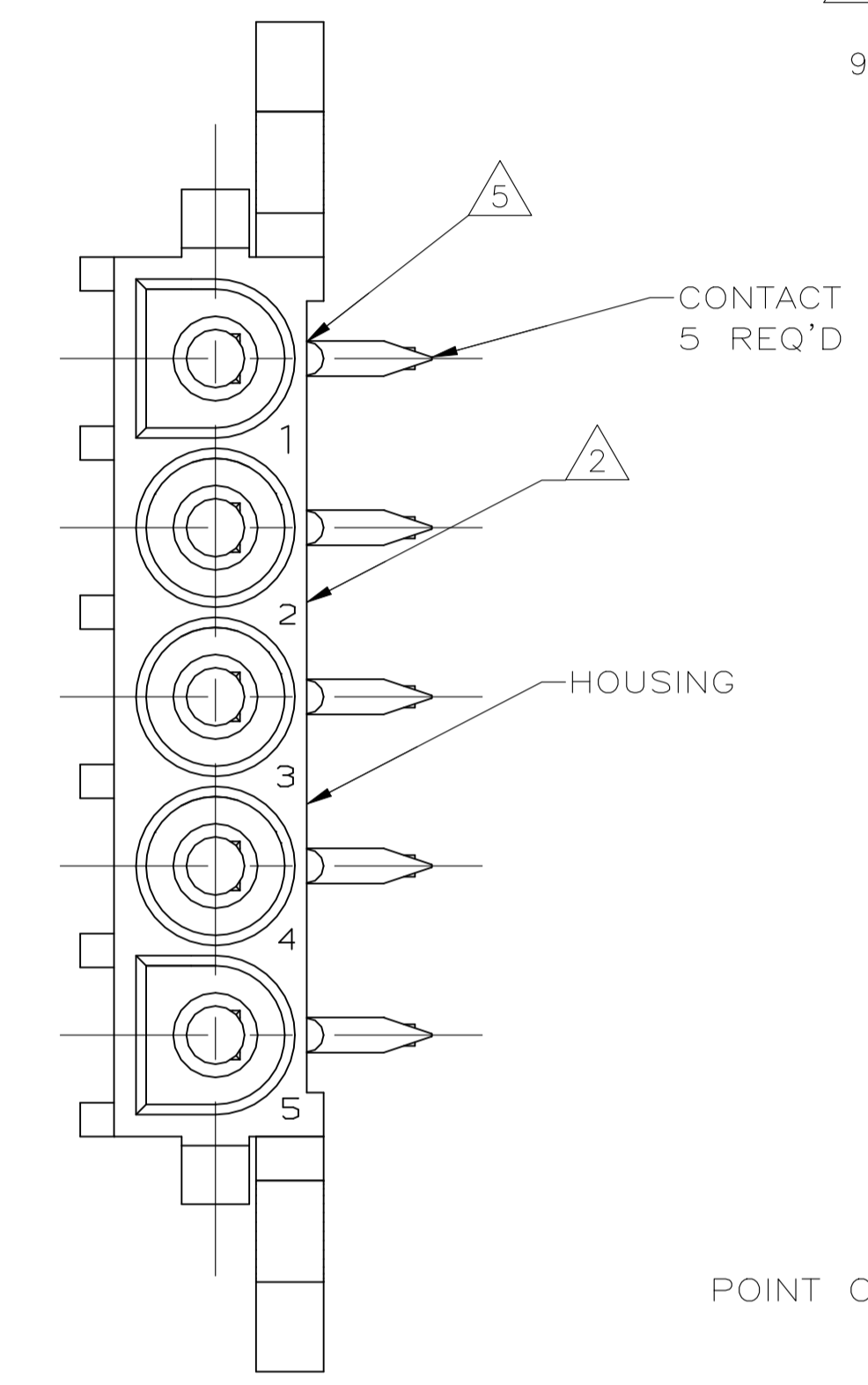
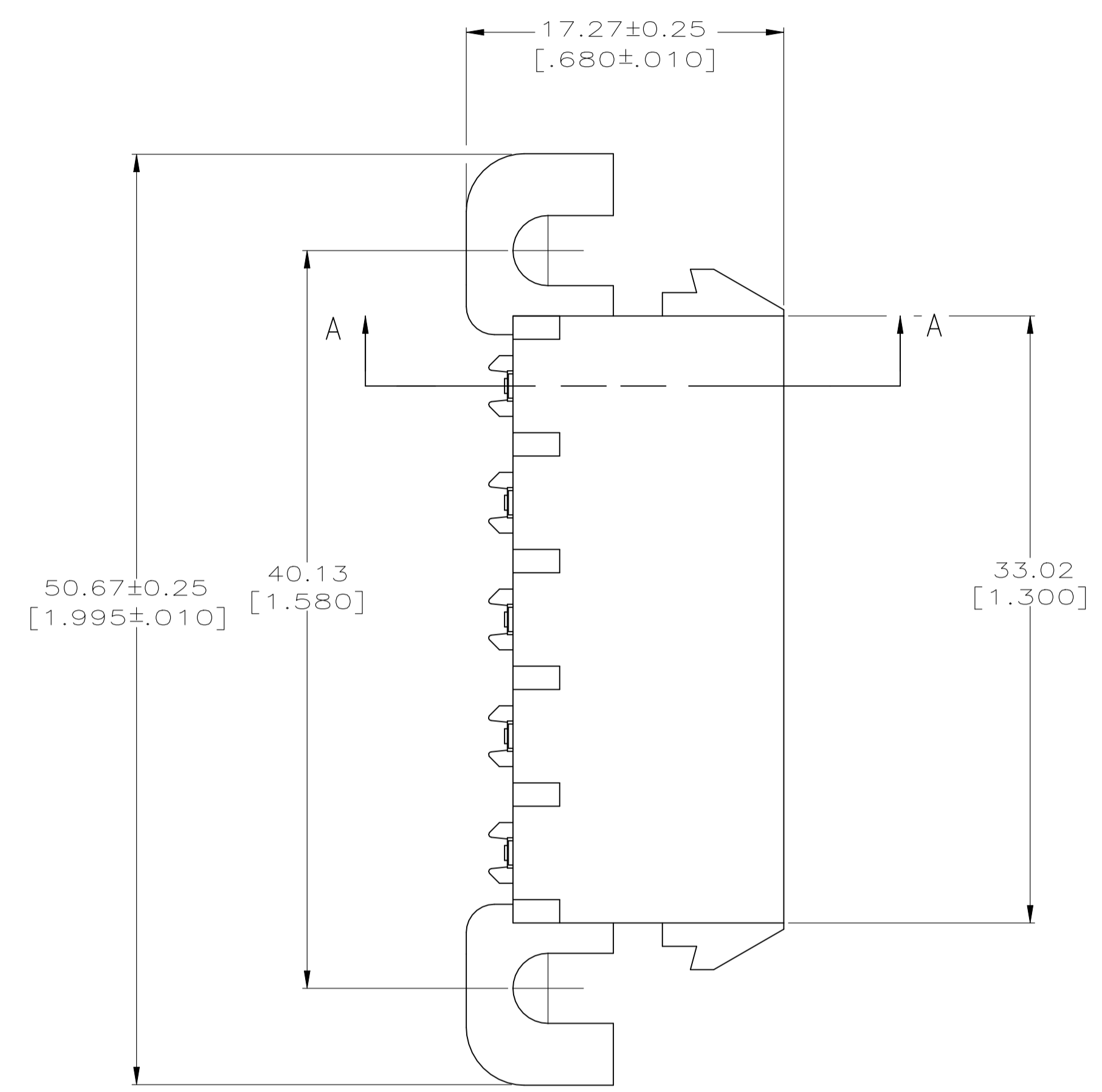
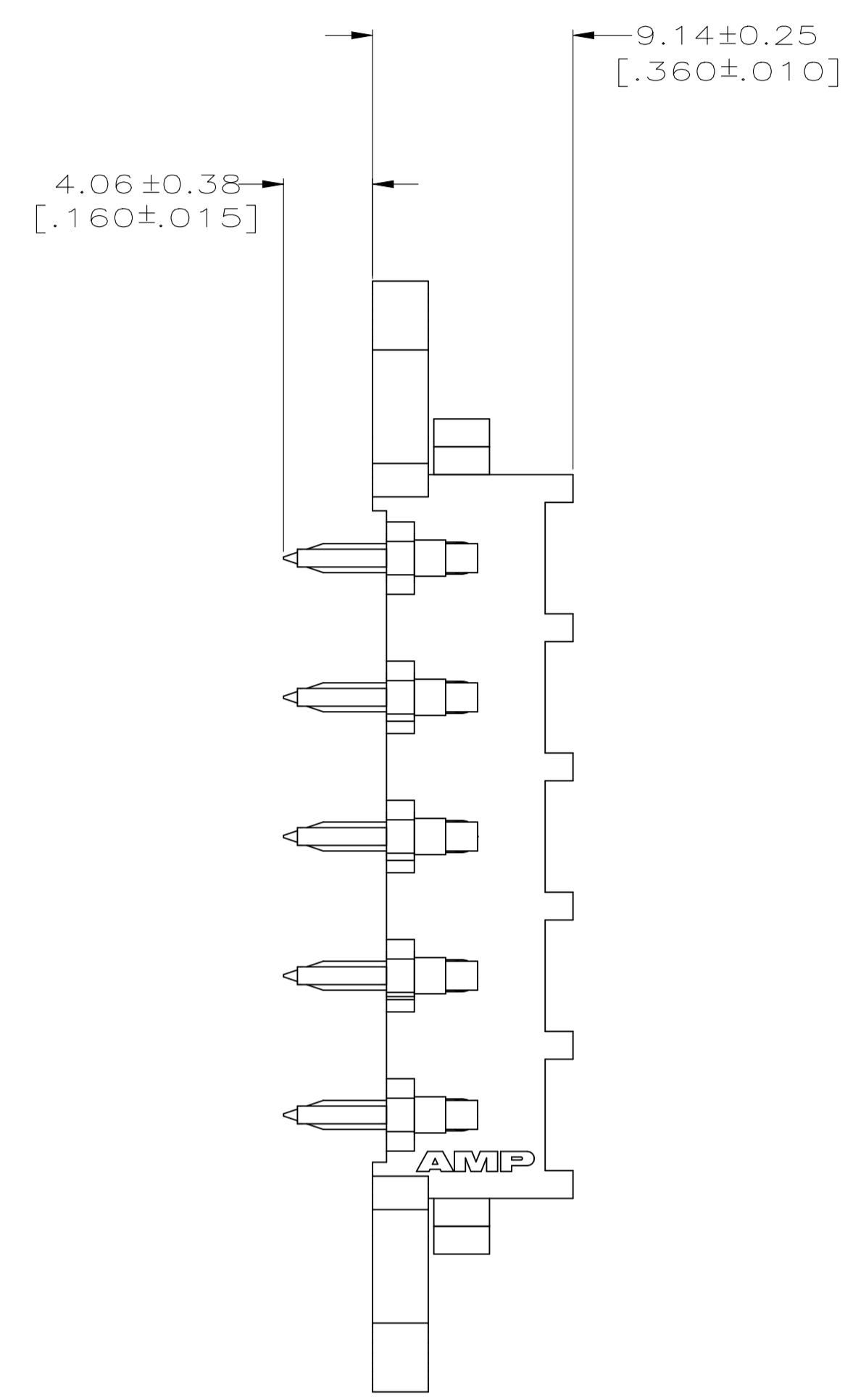
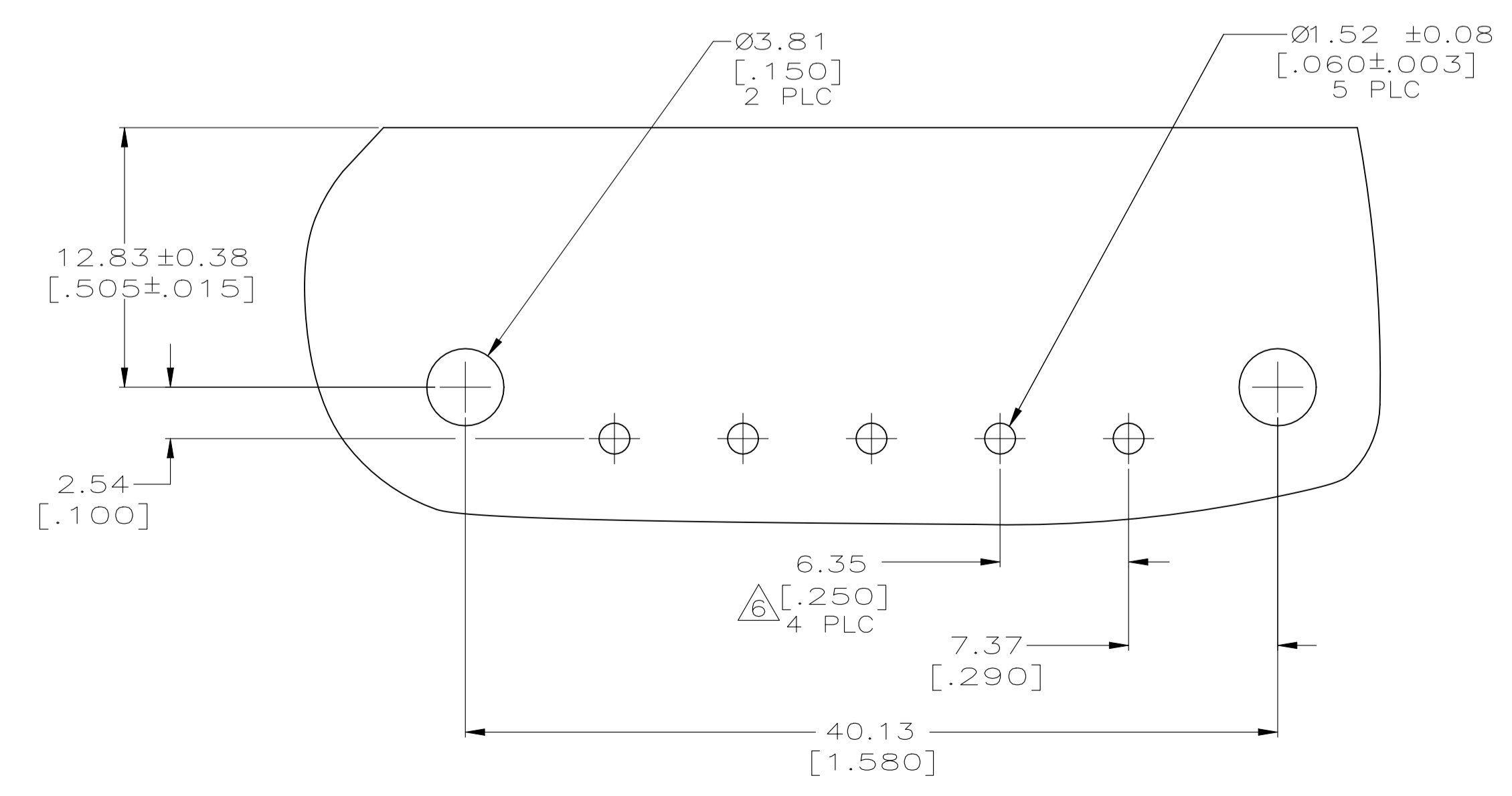

RECOMMENDED MOUNTING HOLE PATTERN FOR .062 [1.57] THICK P.C. BOARD

CONTACT	HOUSING	PART NO
PH BRZ GOLD 7	NYLON, UL94V-0	3-350945-0
PH BRZ GOLD 3	NYLON, UL94V-0	2-350945-0
PH BRZ TIN	NYLON, UL94V-0	1-350945-0

THIS DRAWING IS A CONTROLLED DOCUMENT.

DIMENSIONS: mm [INCHES]	TOLERANCES UNLESS OTHERWISE SPECIFIED:	DIN K. WHITAKER 21APR2005	21APR2005	TE Connectivity
0 PLC ± -	1 PLC ± -	21APR2005	21APR2005	
1 PLC ± -	2 PLC ± -	NAME		PIN HEADER ASSEMBLY, RIGHT ANGLE MOUNT, 5 POSITION, UNIVERSAL MATE-N-LOK (TM)
2 PLC ± -	3 PLC ± 0.13 [.005]	PRODUCT SPEC		
3 PLC ± -	4 PLC ± -	APPLICATION SPEC		SIZE CAGE CODE DRAWING NO A1 00779 C=350945
4 PLC ± -	ANGLES ± ± 0°30'	WEIGHT 0.000000		
MATERIAL SEE TABLE	FINISH SEE TABLE	CUSTOMER DRAWING		RESTRICTED TO
		SCALE 4:1		SHEET 1 of 1
		REV L3		