

CIRCUIT SIZE	DIM A	DIM C	DIM E
2	3.00	6.85	9.74
3	6.00	9.85	12.74
4	9.00	12.85	15.74
5	12.00	15.85	18.74
6	15.00	18.85	21.74
7	18.00	21.85	24.74
8	21.00	24.85	27.74
9	24.00	27.85	30.74
10	27.00	30.85	33.74
11	30.00	33.85	36.74
12	33.00	36.85	39.74

0.2 MAX SINK ALLOWED ON THIS SIDE OF TPA

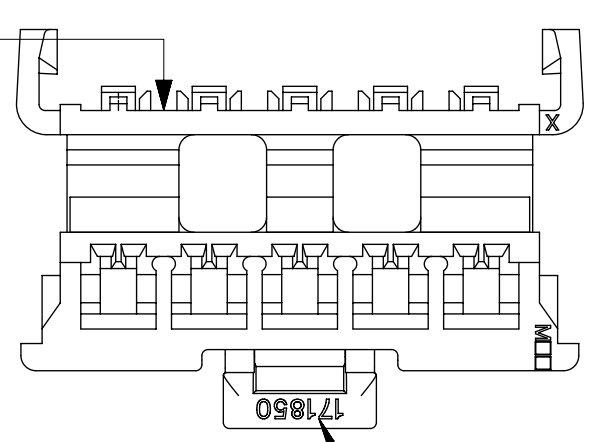

MOLEX SERIES ID

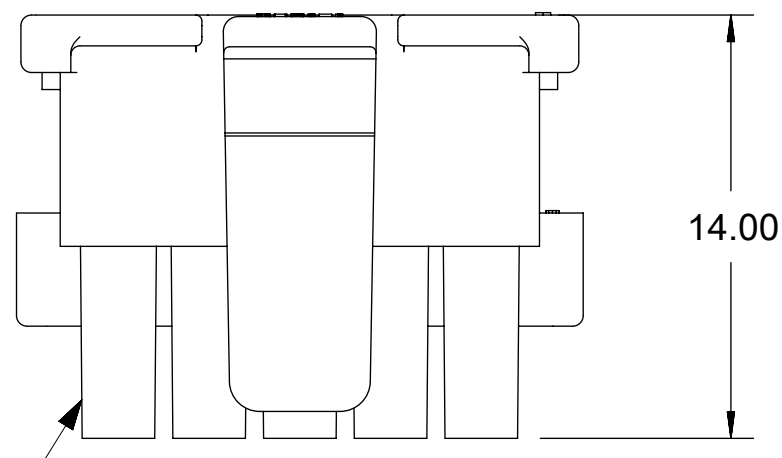

CKT 1

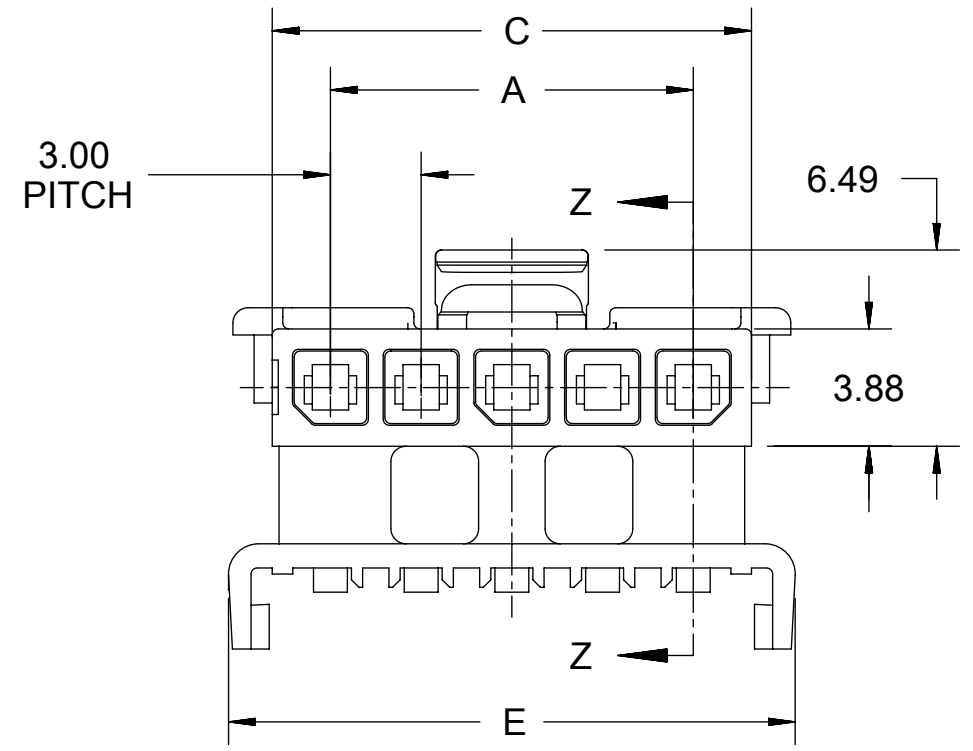

NOTES:

- MATERIAL:
A = NYLON V-0 LOW HALOGEN, COLOR: BLACK
B = NYLON, V-0, GLOW WIRE IEC 60335-1 GLOW WIRE CAPABLE, COLOR: BLACK
- FINISH: NONE
- PRODUCT SPECIFICATION: PS-43650
- PACKAGING SPECIFICATION: PK-171850-0000
- THIS HOUSING TO BE USED WITH MOLEX FEMALE TERMINAL 43030 OR 46235 SERIES.
- THIS PART MATES WITH 43640 AND 43650.
- THIS PART CONFORMS TO CLASS 'B' REQUIREMENTS OF COSMETIC SPECIFICATION PS-45499-002.
- REFER TO AS-45499-001 FOR MOISTURIZING NYLON CONNECTOR PARTS.
- PRODUCT MUST BE USED WITH TPA INSTALLED.
- TPA IS INTENDED FOR ONE TIME USE.
- INTENDED FOR USE WITH 20-30 AWG WIRES ONLY.
- SOME HOUSINGS MAY HAVE A SMALL GATE BLEMISH NEAR THE GATE THAT DOES NOT AFFECT FUNCTIONALITY.
- MOLEX RECOMMENDS THE USE OF MICRO-FIT TEST PLUG, SERIES NO. 44242-**** WHENEVER TESTING IS PERFORMED. TEST PLUGS MUST NOT BE USED FOR MAKE OR BREAK UNDER LOAD. MOLEX DOES NOT RECOMMEND USING STANDARD MATING COMPONENTS FOR HARNESS TESTING PURPOSES.
- TEXT ON PART IS FOR REFERENCE ONLY. TEXT AND TEXT LOCATION MAY VARY DEPENDING ON PART NUMBER AND/OR TOOL.

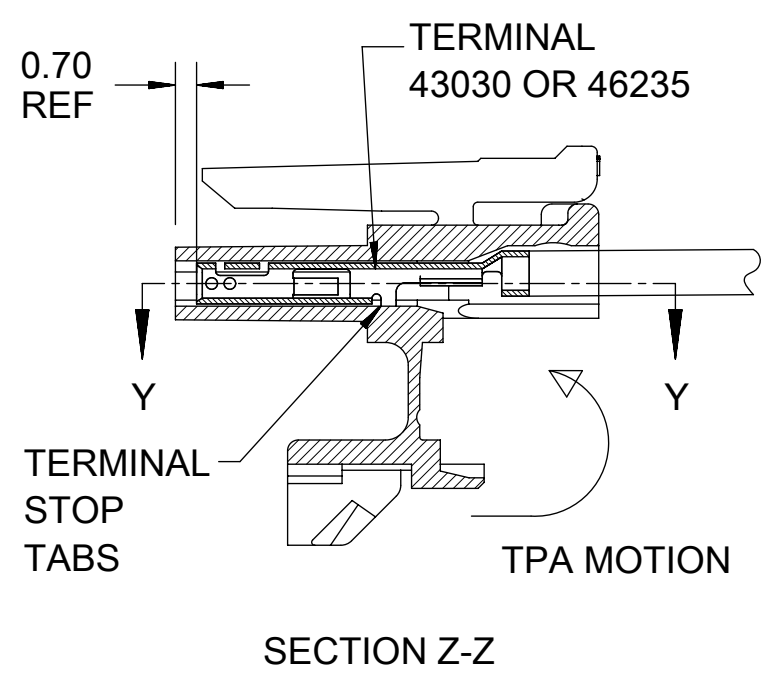
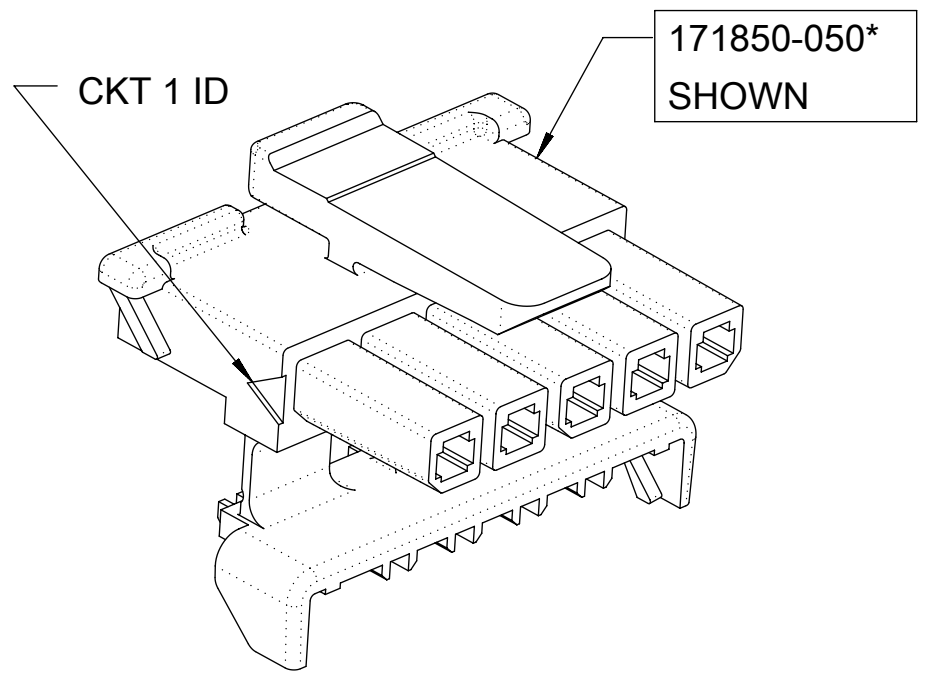
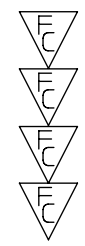

TPA OPEN

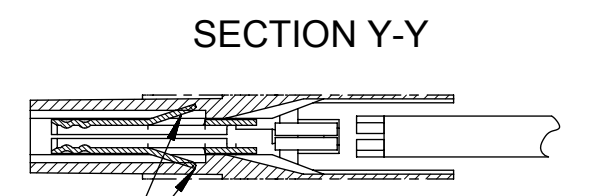

SECTION Y-Y
TERMINAL LOCKING TANGS SHOULD BE FULLY SEATED IN HOUSING BEFORE ACTIVATING THE HINGED TPA

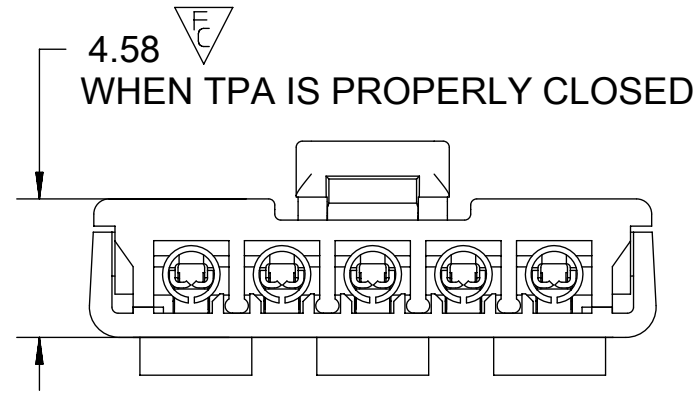
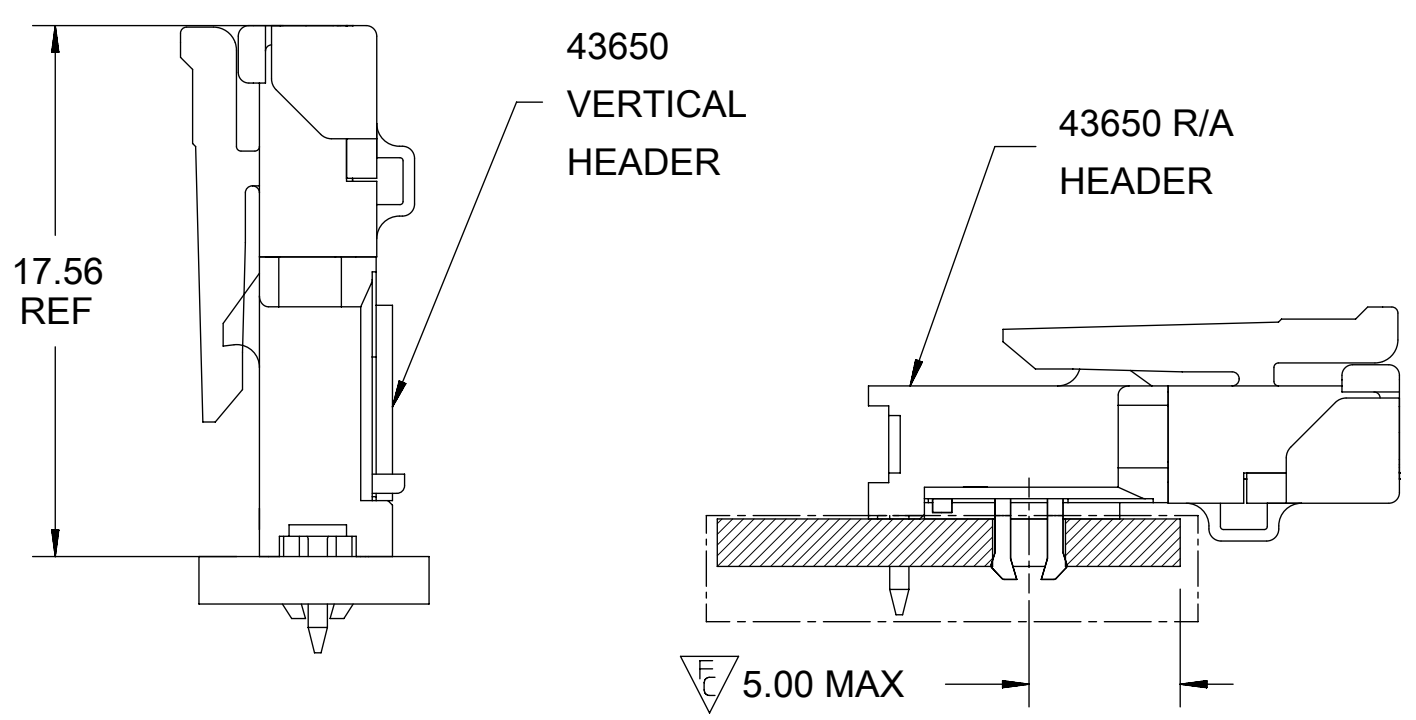

TPA CLOSED

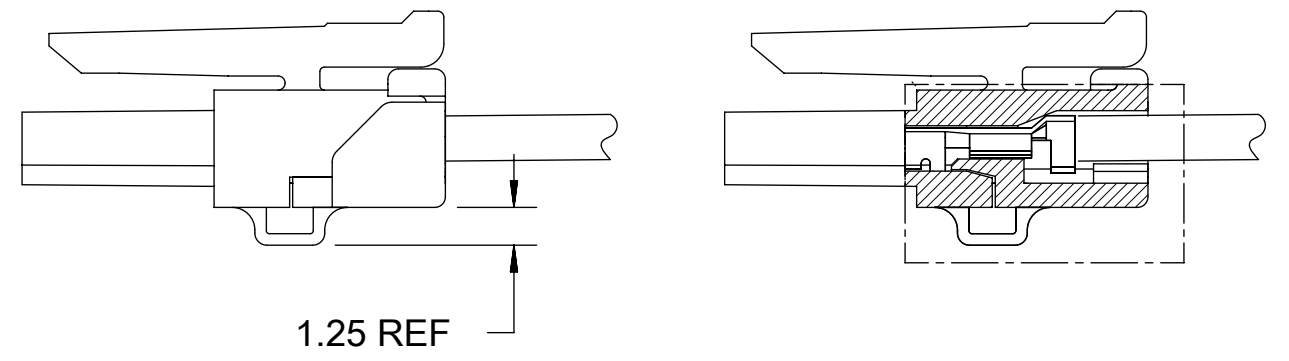

FUNCTIONAL SYMBOLS $\nabla A = 0$ $\nabla C = 6$ $\nabla P = 0$	THIS DRAWING CONTAINS INFORMATION THAT IS PROPRIETARY TO MOLEX ELECTRONIC TECHNOLOGIES, LLC AND SHOULD NOT BE USED WITHOUT WRITTEN PERMISSION		CURRENT REV DESC: ADD GLOW WIRE MATERIAL, 8CKT TOOLED				
	DIMENSION UNITS	SCALE	EC NO: 682217				
	mm	NTS	DRWN: MKIPPER 2020/11/16				
	GENERAL TOLERANCES (UNLESS SPECIFIED)		CHK'D: SSOUSEK 2022/09/06				
DIVISIONAL SYMBOLS 4 PLACES ± 3 PLACES ± 2 PLACES ± 0.25 1 PLACE ± 0 PLACES ±	ANGULAR TOL ± °		APPR: FSMITH 2022/09/07		PRODUCT CUSTOMER DRAWING DOCUMENT NUMBER SD-171850-0000 DOC TYPE DOC PART REVISION PSD 000 B7		
	INITIAL REVISION:		2014/04/07				
	DRWN: CD		2014/04/29				
	APPR: JCOMERCI						
DRAFT WHERE APPLICABLE MUST REMAIN WITHIN DIMENSIONS		THIRD ANGLE PROJECTION	DRAWING	SERIES	MATERIAL NUMBER	CUSTOMER	SHEET NUMBER
			C-SIZE	171850	SEE CHART	GENERAL MARKET	1 OF 2

CIRCUIT SIZE	PART NUMBER	STATUS	MATERIAL
2	171850-0200	TOOLED	"A" V-0 LOW HALOGEN
3	171850-0300		
4	171850-0400		
5	171850-0500		
6	171850-0600		
7	171850-0700		
8	171850-0800		
9	171850-0900		
10	171850-1000	NOT TOOLED	
11	171850-1100		
12	171850-1200		
2	171850-0201	TOOLED	"B" V-0 GLOW WIRE
3	171850-0301		
4	171850-0401		
5	171850-0501		
6	171850-0601		
7	171850-0701		
8	171850-0801		
9	171850-0901	NOT TOOLED	
10	171850-1001		
11	171850-1101		
12	171850-1201		

POLARIZATION LAYOUT

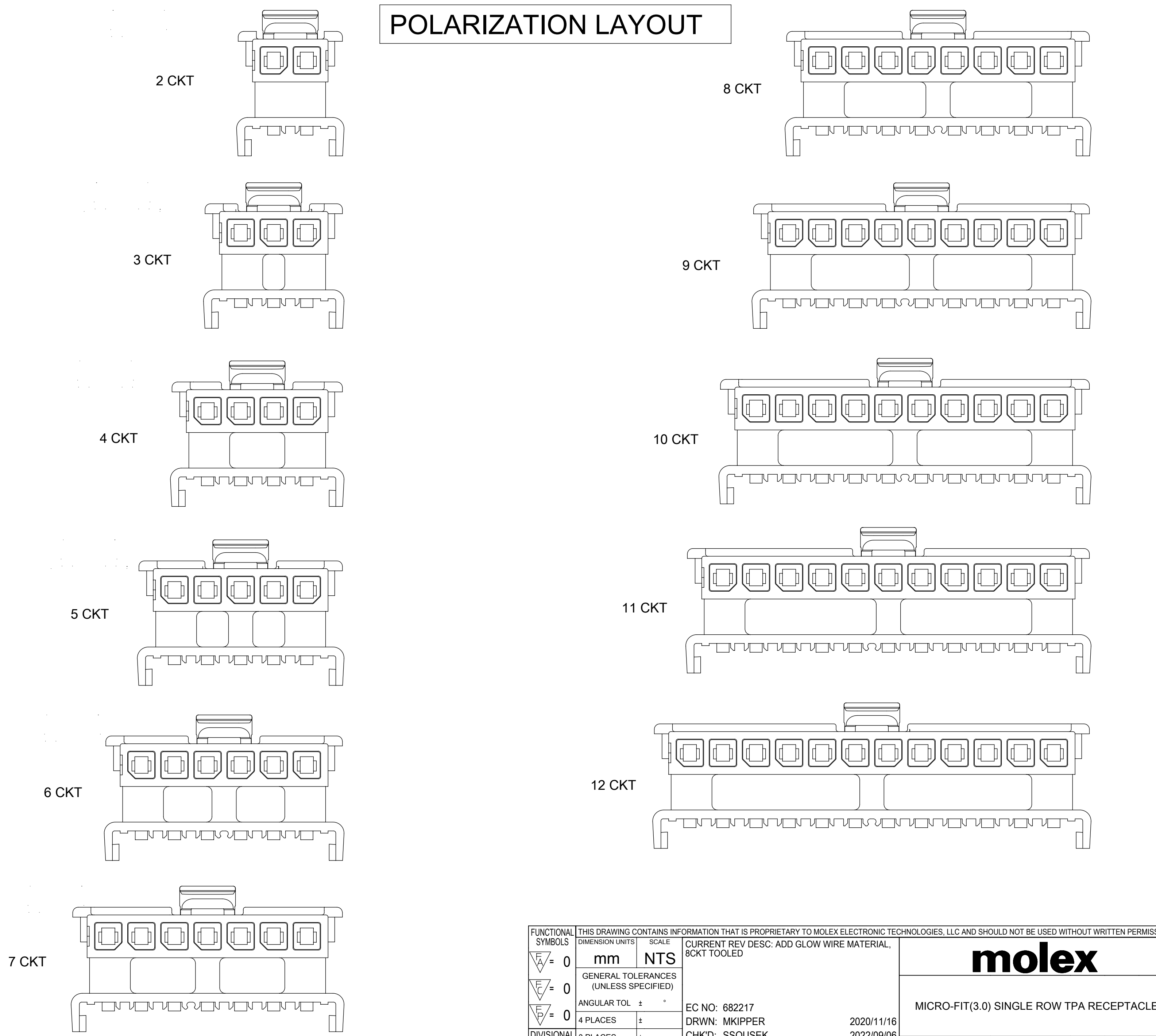

FUNCTIONAL SYMBOLS	THIS DRAWING CONTAINS INFORMATION THAT IS PROPRIETARY TO MOLEX ELECTRONIC TECHNOLOGIES, LLC AND SHOULD NOT BE USED WITHOUT WRITTEN PERMISSION		
	DIMENSION UNITS	SCALE	CURRENT REV DESC: ADD GLOW WIRE MATERIAL, 8CKT TOOLED
$\frac{E}{A} = 0$	mm	NTS	molex MICRO-FIT(3.0) SINGLE ROW TPA RECEPTACLE PRODUCT CUSTOMER DRAWING DOCUMENT NUMBER: SD-171850-0000 DOC TYPE: PSD DOC PART: 000 REVISION: B7 MATERIAL NUMBER: SEE CHART CUSTOMER: GENERAL MARKET SHEET NUMBER: 2 OF 2
$\frac{E}{C} = 0$	GENERAL TOLERANCES (UNLESS SPECIFIED)		
$\frac{E}{D} = 0$	ANGULAR TOL ± °		
DIVISIONAL SYMBOLS	4 PLACES ±	EC NO: 682217	
	3 PLACES ±	DRWN: MKIPPER 2020/11/16	
	2 PLACES ± 0.25	CHK'D: SSOUSEK 2022/09/06	
	1 PLACE ±	APPR: FSMITH 2022/09/07	
	0 PLACES ±	INITIAL REVISION: DRWN: CD 2014/04/07	
		APPR: JCOMERCI 2014/04/29	
DRAFT WHERE APPLICABLE MUST REMAIN WITHIN DIMENSIONS	THIRD ANGLE PROJECTION	DRAWING	SERIES
		C-SIZE	171850